

Water Treatment and Disinfection

Product Catalogue 2024

ProMinent®

Focus on
YOU



Issued by:

ProMinent GmbH
Im Schuhmachergewann 5-11
69123 Heidelberg
Germany
Phone: +49 6221 842-0
info@prominent.com
www.prominent.com



Technical changes reserved.

All previous catalogues and price lists are superseded with the release of this product catalogue.
You can view our general terms and conditions on our homepage.

Heidelberg, January 2024

Product Catalogue Volume 3

Water treatment and water disinfection



Non-technology-dependent solutions from a single source

Chapter 1

UV systems for gentle and chemical-free water treatment. They are ideal for the disinfection of municipal potable water or product water in the beverage industry. UV systems ensure swimming fun in perfectly clear water without undesired combined chlorine in swimming pool water treatment.

Ozone systems are the optimum solution if undesirable organic or inorganic substances need to be effectively removed. The reactive ozone provides efficient disinfection without the formation of by-products. It simply decomposes in water to form oxygen.

Chlorine dioxide offers long-lasting microbial protection, for instance of long pipework in potable water treatment. It can also be used in the most diverse applications in the food industry, for instance bottle rinsers, process water, CIP (cleaning in place).

Electrolysis systems generate chlorine in a chemical-free manner on site from salt and current. There is therefore no need for the transport and storage of potentially hazardous chemicals and the chlorine products are produced just when they are needed. ProMinent electrolysis systems generate chlorine gas for swimming pool disinfection, hypochlorite for potable water treatment and hypochlorous acid for disinfection in the food industry.

Chapter 2

Metering systems ULTROMAT and DULCODOS win customers over with their ease of assembly and operation. They meet very stringent requirements in terms of the separation of colloidal solids from liquids.

Storage tanks are indispensable. They comply with internationally applicable manufacturing approvals and are suitable for installation outdoors and indoors.

Chapter 3

Diaphragm systems are indispensable if particles or dissolved substances, such as salts, need to be removed from the water. Combined with the ProMinent product range, you can source complete water treatment solutions from a single supplier.

Chapter 4

ProMinent's **DULCONNEX** is the smart overall solution for digitally networking your system components.

Focus on you

ProMinent is close to hand no matter where you are: 55 dedicated sales, production and service companies guarantee service and availability in close proximity to our customers. For many years this has meant a local presence for our customers in over 100 countries.



Our sales team will be happy to be of assistance should you have any questions about metering technology or water treatment. You will find the contact details of your local contact at

www.prominent.com/en/locations

Table of contents

Water treatment and water disinfection		Page
1	Disinfection Systems and Oxidation Systems	7
1.1	UV Systems DULCODES	7
1.1.1	General Notes on UV Treatment	7
1.1.2	Performance Overview of UV Systems	10
1.1.3	Questionnaire for Designing a UV System	12
1.1.4	UV System DULCODES LP	13
1.1.5	UV System DULCODES LP certified	15
1.1.6	UV System DULCODES LP F&B	17
1.1.7	UV System DULCODES LP-PE	19
1.1.8	UV System DULCODES LP TL	21
1.1.9	UV System DULCODES MP	23
1.1.10	UV System DULCODES A	25
1.1.11	Accessories for DULCODES UV Systems	28
1.2	Ozone Systems OZONFILT and DULCOZON	30
1.2.1	Ozone in Water Treatment	30
1.2.2	Performance Overview of Ozone Systems	32
1.2.3	Questionnaire on the Design of an Ozone System	33
1.2.4	Ozone System OZONFILT OZVb	34
1.2.5	System Solution OZONFILT Compact OMVb	39
1.2.6	Ozone System OZONFILT OZMa	42
1.2.7	Ozone System DULCOZON OZLa	49
1.2.8	Accessories and Spare Parts for Ozone Systems	52
1.2.9	Room Air Monitoring	57
1.2.10	Personal Protection Accessories	60
1.3	Bello Zon Chlorine Dioxide Systems	61
1.3.1	Chlorine Dioxide in Water Treatment	61
1.3.2	Performance Overview of Chlorine Dioxide Systems	63
1.3.3	Questionnaire on the Design of a Chlorine Dioxide System	64
1.3.4	Chlorine Dioxide System Bello Zon CDLb	65
1.3.5	Chlorine Dioxide System Bello Zon CDLb H ₂ SO ₄	67
1.3.6	Chlorine Dioxide System Bello Zon CDLb with Multiple Points of Injection	73
1.3.7	Chlorine Dioxide System Bello Zon CDEb	74
1.3.8	Chlorine Dioxide System Bello Zon CDVd	76
1.3.9	Chlorine Dioxide System Bello Zon CDKd	80
1.3.10	Storage Tank Accessories	85
1.3.11	Bypass Line Accessories	86
1.3.12	Chemical Supply Accessories	87
1.3.13	Safety Accessories and Analysis	89
1.4	Electrolysis Systems CHLORINSITU and DULCOLYSE	93
1.4.1	Electrolysis Systems CHLORINSITU	93
1.4.2	Performance Overview of Electrolysis Systems	94
1.4.3	Questionnaire on the Design of an Electrolysis Plant	95
1.4.4	Electrolysis System CHLORINSITU Ila 60 – 2,500 g/h	96

Table of contents

Water treatment and water disinfection		Page
1.4.5	Electrolysis System CHLORINSITU IIa XL	100
1.4.6	Electrolysis System CHLORINSITU III	102
1.4.7	Electrolysis System CHLORINSITU III Compact	104
1.4.8	Electrolysis System CHLORINSITU IV Compact	106
1.4.9	Electrolysis System CHLORINSITU V	108
1.4.10	Electrolysis System CHLORINSITU V Plus	110
1.4.11	Questionnaire on the Design of a DULCOLYSE Electrolysis System	112
1.4.12	Electrolysis System DULCOLYSE	113
1.4.13	Accessories	115
2	Metering Systems	116
2.1	Polymer Preparation and Metering Systems	116
2.1.1	Polyelectrolytes in Water Treatment	116
2.1.2	Performance Overview of Polymer Preparation and Metering Systems ULTROMAT, DULCODOS and PolyRex	117
2.1.3	Questionnaire for the Design of Polymer Preparation and Metering Systems ULTROMAT, DULCODOS and PolyRex	118
2.1.4	Preparation Stations and Metering of Powdered and Liquid Polymer Solutions ULTROMAT and DULCODOS	119
2.1.5	Metering System ULTROMAT ULFa	120
2.1.6	Metering System ULTROMAT ULPa	125
2.1.7	Metering System ULTROMAT ULDa	129
2.1.8	Metering System DULCODOS ULIa (Inline System Liquid)	133
2.1.9	Metering System ULTROMAT MT for Batch Operation	137
2.1.10	ULTROMAT and DULCODOS Accessories Including Big Bag Systems	139
2.1.11	Batching Stations and Metering of Powdered and Liquid Polymer Solutions PolyRex	142
2.1.12	Metering System PolyRex	143
2.1.13	Metering System PolyRex Big Bag	145
2.1.14	Metering System PolyRex Liquid	147
2.1.15	PolyRex Accessories – Mixing Systems	148
2.1.16	TOMAL® Multi-Screw Feeder	149
2.2	Metering and Emptying Station DULCODOS SAFE-IBC	150
2.2.1	Metering and Emptying Station DULCODOS SAFE-IBC	150
2.3	Storage and Process Tanks	153
2.3.1	PE/PP Storage Tank, General	153
2.3.2	PE Storage Tank With General WHG Approval	154
2.3.3	Accessories According to the Specifications of the Federal Water Act (WHG) and/or the Ordinance on Installations for the Handling of Substances Hazardous to Water (VAWS)	156
2.3.4	Other Accessories	158
2.3.5	PP/PE Process Storage Tank, Customised	159
3	Filtration	161
3.1	Overview of Membrane Technology	161
3.2	Ultrafiltration Systems	162
3.2.1	Performance Overview of Ultrafiltration	162



Table of contents

Water treatment and water disinfection		Page
3.2.2	Questionnaire on the Design of a UF System	164
3.2.3	Ultrafiltration Systems DULCOCLEAN UF	165
3.3	Nanofiltration Systems	167
3.3.1	Nanofiltration System DULCOSMOSE NF	167
3.4	Reverse Osmosis Systems	169
3.4.1	Performance Overview of Reverse Osmosis	169
3.4.2	Questionnaire on the Design of an RO System	171
3.4.3	Reverse Osmosis System DULCOSMOSE TW	172
3.4.4	Reverse Osmosis System DULCOSMOSE BW	174
3.4.5	Reverse Osmosis System DULCOSMOSE SW	176
4	Digital solutions	178
4.1	DULCONNEX: IIoT Solution for Digital Fluid Management	178
4.1.1	Smart Process Monitoring – Any time, Anywhere	178
4.1.2	Reference Waterworks	179
4.1.3	Reference Hotel	179
4.1.4	Your Benefits of Digital Fluid Management	181
4.1.5	DULCONNEX Gateway	182
4.1.6	DULCONNEX Blue	183
4.1.7	DULCONNEX Platform	185
4.1.8	DULCONNEX Inventory Management	187
4.1.9	DULCONNEX API	188

New Products Water Treatment and Water Disinfection



Electrolysis System CHLORINSITU IIa 60 – 2,500 g/h

Enhanced efficiency through innovative design.

The CHLORINSITU IIa product range combines the proven and durable design of the undivided electrolysis cell with an innovative design. An exceptional quality of hypochlorite solution is achieved when the salt and power output is increased. The chlorate content of the product is below the limit value specified in EN 901.

The electrolysis system is perfectly equipped for all safe water disinfection with a capacity of up to 2500 g of chlorine per hour.

All relevant system components are accommodated in a space-saving housing. Integrated hydrogen drainage enables the system to be installed without any need for additional ventilation.

The softener and a 50-litre product tank are installed in the system housing with systems up to 300 g/h. An integrated metering pump circulates the chlorine from the tank directly to the application or into a larger storage tank.

An H₂ deaerator dissolves the hydrogen directly from the hypochlorite with systems above 625 g/h. The hydrogen-free product is pumped by an integrated pump into an external product tank. The product pump is also capable of pumping across height differences of up to 7 m. Customised metering stations supply the points of injection.

The external product storage tank does not require additional hydrogen bleeding. There are therefore no additional costs relating to installation and operation.

The system is immediately ready for use, thanks to its plug-and-play concept. Operation of the electrolysis system has been consciously kept simple.

- Durable design, reliable technology
- Low-chlorate product (below the EN 901 limit value)
- High output: only 3.0 kg of salt per kg of chlorine
- Reduced energy consumption: only 4 kWh/kg chlorine
- Minimal maintenance work and ease of operation
- System monitoring in real time from any location via DULCONNEX Platform: improved process reliability, overall reliability and transparency through real-time monitoring, individual alarms and automated reports (optional)

For more information see page →96



Electrolysis system DULCOLYSE

Disinfection with low levels of chlorate and chloride; NEW: capacity of up to 800 g/h

The electrolysis system DULCOLYSE now has an even larger capacity range. It produces up to two cubic metres of disinfection solution an hour. The disinfectant DULCOLYLT produced on-site is not only highly effective, but also has very low chlorate and chloride values. This makes the system perfectly suited to particularly sensitive applications, such as the production of baby food.

DULCOLYSE is the right product for manufacturers of foodstuffs and beverages who have large production-sites or several points of injection.

- Ultra-low chlorate content for disinfection with minimal by-products
- Extremely low chloride content for high protection and freedom from corrosion within the plant
- Environmentally-friendly, highly effective disinfection
- Long-term freedom from germs, without any transport, storage or handling of chemicals

For more information see page →113



New Products Water Treatment and Water Disinfection

Metering and emptying station DULCODOS SAFE-IBC for earthquake zones

New design for earthquake zones 1 to 3

The metering and emptying station DULCODOS SAFE-IBC provides your process with chemicals with no interruptions.

Thanks to a specially developed design, extra attachments and protective measures, the new DULCODOS SAFE-IBC design offers protection from the effects of earthquakes and meets the requirements laid down in DIN 4149 and DIN EN 1998-1.

- Intermediate tank secured in collection pan using special base plates
- Anti-slip mat under the IBC provided by the customer
- Lashing straps / 4x can be connected for the customer to affix the IBC
- PE floor claws with stainless steel plates to be fastened to all sides of the collection pan on-site
- Recommended on-site anchorage to the floor using DIBt-certified chemical Rawlplugs
- DIBt approval Z-40.21-585

For more information see page →150





1.1 UV Systems DULCODES

1.1.1 General Notes on UV Treatment

Disinfection is a key stage in modern water treatment. UV disinfection is used to ever-increasing extent as a safe, chemical-free and reliable disinfection process. Extensive research projects and numerous systems operating without any issues prove the safety and reliability of UV disinfection.

With UV disinfection, the water to be disinfected is irradiated with ultraviolet light. This is a purely physical, chemical-free process for water disinfection.

UV-C radiation in particular, with a wavelength ranging from 240 to 280 nm, attacks the vital DNA of the germs directly. The radiation initiates a photochemical reaction and destroys the genetic information contained in the DNA. The germs lose their reproduction capability and are destroyed. Even parasites, like Cryptosporidia or Giardia, which are extremely resistant to chemical disinfectants, are efficiently reduced.

Photochemical reactions are triggered in other applications too. For example, the undesirable use of combined chlorine in swimming pool water is reduced through UV radiation, resulting in enormous freshwater savings. Oxidants, such as ozone, chlorine or chlorine dioxide, are reliably reduced in the production water used in the food and pharmaceutical industry, avoiding the need for costly activated carbon filters.

UV disinfection has many advantages:

- Immediate and safe disinfection without the addition of chemicals
- Photochemical reduction of undesirable substances
- No THM or AOX formation, no formation of other undesirable substances
- No impairment of the odour or taste of the water
- No storage and handling of chemicals required
- Effect is independent of the pH value
- No reaction line or reaction tank required
- Minimal space requirement
- Low investment and operating costs with excellent reliability and efficiency

Applications of DULCODES UV Systems

A large number of our UV disinfection systems have been supplied worldwide, for the most diverse of applications:

- **Private water suppliers and municipal water works**
 - for the disinfection of drinking water
- **Food and beverage industry**
 - to destroy germs and bacteria in the water needed for food and beverage production and for disinfection of process water
 - for the reduction of chlorine dioxide, ozone or chlorine in product water
 - for the disinfection of sugar syrup
- **Pharmaceutical and cosmetics industry**
 - to meet the high microbiological requirements of the production water
 - to destroy residual ozone in the production water without the use of activated carbon filters
- **Reverse osmosis systems**
 - for permeate disinfection
- **Horticulture**
 - for the disinfection of irrigation water
- **Spa pools and swimming pools**
 - to boost disinfection of the pool water
 - for chloramine reduction in the pool water

Description of DULCODES UV Systems

DULCODES UV disinfection systems essentially consist of:

- High-quality radiation chambers made of stainless steel (DIN 1.4404) or UV-resistant plastic
- Lamp protection tubes made of high-quality quartz, easily removable for cleaning purposes
- Lamps with an exceptionally high UV output in the 254 nm range
- Highly selective UV sensors with good long-term and temperature stability
- UV system controllers and modern electronic ballasts fitted in a control cabinet

1.1 UV Systems DULCODES

The special features of our DULCODES UV disinfection systems are:

- Homogeneous UV dose distribution thanks to optimised flow behaviour in the reactor guarantees maximum flow output with a minimum number of lamps and minimum pressure loss
- Reduced life cycle costs due to the long service life of high-output lamps with low energy consumption and high UV yield
- Unique active temperature management of VARIO-Flux low-pressure technology adapts the lamp output in seconds and provides for optimum disinfection even with rapidly changing flows and temperature conditions
- Efficient and chemical-free cleaning of the cover tubes with manual or automatic wiper system without interruption to operation
- Continuous monitoring of the reactor temperature by temperature sensor Pt 1000
- Electronic ballasts for gentle ignition and operation and individual monitoring
- DULCODES LP control cabinet with efficient recirculation cooling ensures the long life of electronic components and protects against corrosion in aggressive ambient conditions
- Various options for simple integration of the system in higher-level control systems thanks to many analogue and digital interfaces and connectors
- User-friendly and intuitive control for displaying operating statuses and adjusting operating parameters
- Comprehensive biosimetric validation in line with EPA-UVDGM or DIN/DVGW and ÖVGW certification for selected product ranges confirm disinfection efficiency

DULCODES UV lamps

Low-pressure lamps VARIO-Flux

Recently developed and patented high-performance amalgam lamp with a guaranteed life expectancy of 14,000 operating hours (pro rata). The lamps are characterised by their high UV yield and minimal ageing behaviour. Thanks to the unique combination of electronic ballast technology and the VARIO-Flux lamps, they can be controlled quickly and precisely over a broad capacity range of up to 50% of the nominal power. Seasonal fluctuations in water temperature are no longer an issue and are simply compensated for by the active temperature management of the lamps. Efficiency increases even in dimmed mode. This has a particularly positive effect when the actual flow is below the system's maximum possible flow. The special technology also enables vertical and horizontal installation.

Medium-pressure lamp Powerline

Medium-pressure mercury lamps with a life expectancy of approx. 8000 to 10,000 operating hours, depending on the lamp size. The high output of these lamps enables very large flows to be treated. Thanks to their broad range spectrum, these lamps are particularly well suited to photochemical processes. The operating temperature of the lamps is 650 – 850 °C. The water temperature is therefore monitored and the system switches off when a limit temperature is exceeded.

DULCODES UV Controllers

Compact controller

Compact unit for controlling all the UV system's functions. The controller can be selected for single-lamp systems of the DULCODES LP product range. The display alternately shows the current radiation intensity, the operating hours and the number of lamp switch-ons. The Compact controller informs the operator if values fall below freely programmable safety and warning thresholds. Different functions, such as commissioning flushing, interval flushing, idle flushing and a run-on time can be freely set to meet demand.

The controller has the following inputs and outputs:

- Connection for both a flushing and shut-off valve (230 V)
- Potential-free contact output for the end of lamp service life, power failure and warning
- Potential-free changeover output for operating and common alarm messages
- Potential-free contact input for temperature or flow control and pause
- 4-20 mA standard signal output for sensor signal

Comfort controller UVCb

The Comfort controller consists of a control PCB and a remote display and control unit integrated in the door of the control cabinet. The UV systems are controlled in a user-friendly and intuitive manner. All operating statuses are shown on the display and all operating and fault messages are issued in plain text. The system's operating status (Operation/Warning/Fault) can be seen from afar by means of LEDs.

The Comfort controller UVCb is connected to the electronic ballasts via a bus system so that each individual lamp can be precisely monitored. Different cable lengths are detected automatically and the operating parameters adjusted accordingly. The interaction between the coordinated controller, electronic ballasts and UV lamp components enables the output of the low- and medium-pressure lamps to be adjusted to the water quality or water flow via an external 4-20 mA standard signal.



1.1 UV Systems DULCODES

Various auxiliary functions, such as the automatic flushing of the system over a freely programmable flushing time, the control of a shut-off valve and a circulating pump are integrated as standard. The controller is responsible for controlling the automatic wiper system. During the wiping process, the position is checked a number of times for absolute operational safety of the wiper system. This is done by monitoring the end position and by continuous data exchanges between the wiper motor and controller.

The UVC sensor signal can be monitored online via a standard signal output 0/4-20 mA. Any transgressions of the warning threshold, minimum radiation strength and faults are reported via contact outputs. The reactor temperature is monitored by a temperature sensor to avoid the temperature being impermissibly exceeded.

Potential-free control inputs make it possible to connect to external higher-order systems: The 'Pause' input can be used to regularly interrupt system operation, with the 'External fault' contact input leading to the system being shut down in the event of a fault on a peripheral component connected externally. If the application requires different UV doses, a contact input can quickly adapt the UV dose to the changing requirement.

The Comfort controller UVCb features an operating diary. All events are saved on an SD card and can simply be read off on a PC. The UV sensor signal and other measuring parameters, connected to the controller via external standard signals, are stored on the SD card at set time intervals.

The controller has the following inputs and outputs:

- 3 switched voltage outputs for flushing and shut-off valve and feed pump (230 V or 24 V)
- 3 potential-free contact outputs for warning, common alarm and operating messages
- 4 potential-free contact inputs for pause, external fault, activate emergency mode, setpoint 1/2 switchover
- 1 standard signal output 4-20 mA for sensor signal
- 2 standard signal inputs 4-20 mA for flow and turbidity or combined chlorine with a limit value function
- CAN-bus interface for integrating higher-level controls

Comfort controller DULCODES A

A Siemens S7- 1200 controller with a KP 300 Basic operating panel is used to operate and control DUL-CODES A systems. The functionality corresponds to that of the Comfort controller UVCb.

1.1 UV Systems DULCODES

1.1.2 Performance Overview of UV Systems

ProMinent offers a wide range of UV systems for the most diverse applications. The following overview shows the capacity and main applications of our standard systems:

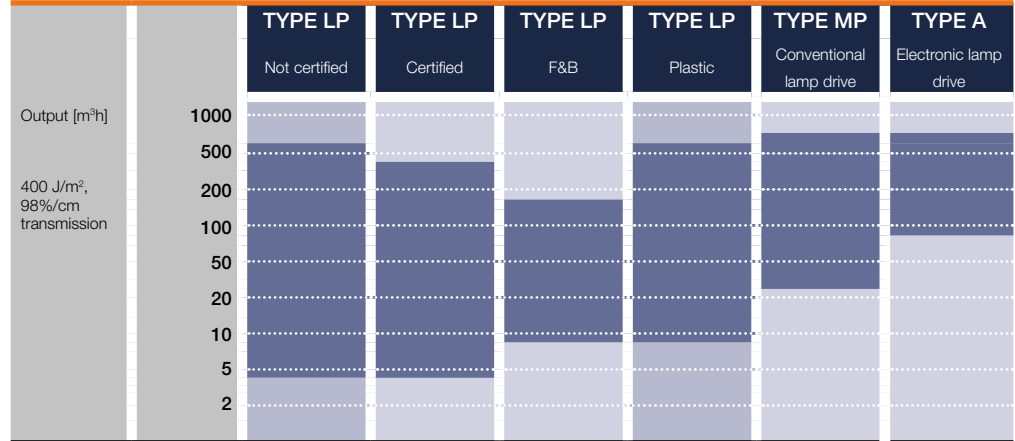

Applications	TYPE LP (Not certified)	TYPE LP (Certified)	TYPE LP (F&B)	TYPE LP (Plastic)	TYPE MP (Conventional lamp drive)	TYPE A (Electronic lamp drive)
Drinking water	■	■				■
Process water	■	■		■	■	■
Swimming pool water	■			■	■	■
Salt water				■		
Food and beverage industry		■	■			

Type LP: Low-pressure

Type MP/A: Medium pressure

ProMinent provides all the advice you need to safely operate a DULCODES UV system:

- Evaluation of the situation on-site by trained, expert field sales staff
- Project planning of the system
- Commissioning and system maintenance by our trained service technicians

1





1.1 UV Systems DULCODES

Notes on Planning and Designing an UV System

- The system should always be designed for the highest water flow.
- The system should always be designed for the lowest expected UV transmission.
- Fireproof sample valves for microbiological tests should be provided upstream and downstream of UV disinfection systems. The sample valves should be fitted upstream and downstream of the UV device in the pipework with adequate spacing (at 3-5 times the size of the pipe diameter).
- Provide a manual shut-off valve upstream of the UV system to isolate the system for maintenance work.
- Provide an electrically controlled shut-off valve downstream of the UV disinfection system for drinking water disinfection and similar applications, which also closes automatically in the event of mains power failure (solenoid valve, automatic closing flap valve or similar).
- With process water disinfection, it is normally sufficient to provide a manual valve to isolate the system for maintenance work, instead of an electrically controlled valve.
- Provide a rinse valve downstream of UV disinfection for drinking water disinfection and similar applications.
- It must be ensured that there is sufficient space available for removing the lamp protection tube and lamp replacement.

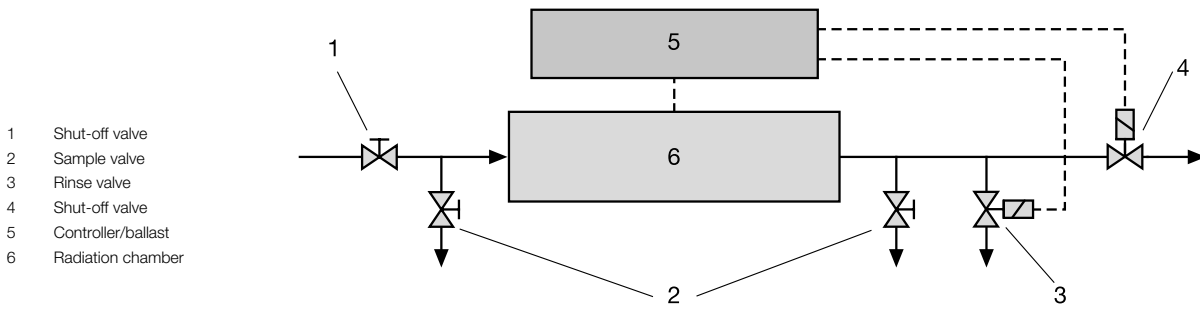

Typical installation diagram of a UV disinfection system

The following details are required for the design of a UV disinfection system:

- Application of the system
- Maximum water flow
- Minimum UV transmission of the water

The UV transmission should be determined by means of a laboratory measurement of the absorption at 254 nm.

A full water analysis allows important conclusions to be drawn on the operating conditions of the UV system. The following questionnaire provides our project engineers with the information they need to design an appropriate system.

1.1 UV Systems DULCODES

1.1.3 Questionnaire for Designing a UV System

Application of the UV system:

- for disinfection of
 - drinking water
 - production water in the food industry, cosmetics or pharmaceuticals
 - utility water
 - wastewater
 - salt water or brackish water
 - _____
- for photochemical reduction of
 - _____ ppm ozone
 - _____ ppm chlorine dioxide
 - _____ ppm chlorine
 - _____ ppm chloramine

Water data:

Maximum water flow _____ m³/h Maximum water pressure _____ bar
 Minimum UV transmission at 254 nm _____ %/1 cm _____ %/10 cm _____ SAC 254 nm

Turbidity _____ FNU _____ NTU

Suspended particles content _____ mg/l

Water quality constant fluctuating

Total hardness _____ mmol/l _____ °dH

Carbonate hardness _____ mmol/l _____ °dH

Chloride _____ mg/l

Manganese _____ mg/l

Iron _____ mg/l

Water temperature _____ °C

Other requirements:





1.1 UV Systems DULCODES

1.1.4 UV System DULCODES LP

Precise lamp dimming in seconds – even with varying flows and water temperatures

Flow up to 523 m³/h



The unique UV systems DULCODES LP are synonymous with pioneering water treatment – efficient and free of chemicals.



Our patented VARIO-Flux high-output lamps with dynamic lamp heating are used in the DULCODES LP. Thanks to the unique combination of electronic ballast technology and the VARIO-Flux lamps, the lamps can be quickly and precisely dimmed over a broad capacity range of up to 50% of the nominal electrical power. This ensures automatic adjustment to varying flows and water temperatures at all times.

Efficiency even increases in dimmed mode, which has a particularly positive effect when the actual flow is below the system's maximum possible flow.

The flow in the DULCODES LP has been optimised in a reactor based on intensive computer simulation. At the same time the pressure loss is kept to a minimum. The resulting uniform radiation dose of a partial volumetric flow (without over-metering or under-metering) leads to minimal use of energy, a minimum number of lamps and significantly reduced life cycle costs.

Your Benefits

- UV system DULCODES LP for a broad field of application for efficient, safe and chemical-free water disinfection
- Unique dynamic lamp heating adjusts the lamp output in seconds and provides for reliable disinfection even with varying flows and water temperatures
- Homogeneous UV dose thanks to optimised flow behaviour in the reactor guarantees maximum flow output with a minimum number of lamps and minimum pressure loss
- Reduced life cycle costs due to the long service life of VARIO-Flux high-output lamps with low energy consumption and high UV yield
- Excellent flexibility thanks to vertical or horizontal installation and free choice of the flange position
- System monitoring in real time from any location via the DULCONNEX Platform: Improved process reliability. Reliability and transparency thanks to real-time monitoring, individual alarms and automated reports.
- User-friendly and intuitive control for displaying operating statuses and adjusting operating parameters
- Control cabinet with efficient recirculation cooling ensures the long life of electronic components and protects against corrosion in aggressive ambient conditions
- Data logger: all relevant operating data and events are saved on the SD card and can be simply and conveniently visualised with an analysis programme



Technical Details

- High-grade stainless steel 1.4404/316L reactor hydraulically optimised by means of computer simulation
- High-output amalgam lamp "VARIO-Flux" with dynamic lamp heating
- Guaranteed lamp service life of 14,000 operating hours (pro rata)
- Electronic ballasts for gentle lamp ignition, operation and individual monitoring as well as control
- Long-term stable UVC sensor for continuous monitoring of the system
- Efficient and chemical-free cleaning of the cover tubes with manual or automatic wiper system, available for selected system sizes as options
- Continuous monitoring of the reactor temperature by temperature sensor Pt 1000
- Single-lamp system: equipped with either a Compact controller or Comfort controller
- Various options for simple integration of the system in higher-level control systems via numerous analogue and digital interfaces
- Data logger: all relevant operating data and events are saved on the SD card and can be simply and conveniently visualised with an analysis programme

Field of Application

- Potable water treatment
- Food and beverage production
- Swimming pool water

1.1 UV Systems DULCODES

Design versions

The DULCODES LP systems are available in the following design versions:

Type	Compact controller	Comfort controller	Lamp dimming	Wiper	Stainless steel control cabinet	AC control cabinet	NSF 50-certified	UL/CSA-compliant
1x80 LP	Yes	No	No	No	No	No	No	No
1x230 LP	Yes	Yes	Yes	No	Yes	Yes	Yes	Yes
1x350 LP	Yes	Yes	Yes	Yes	Yes	Yes	Yes	Yes
2x350 LP	No	Yes	Yes	Yes	Yes	Yes	Yes	Yes
3x230 LP	No	Yes	Yes	No	Yes	Yes	Yes	Yes
3x350 LP	No	Yes	Yes	Yes	Yes	Yes	Yes	Yes
4x350 LP	No	Yes	Yes	Yes	Yes	No	No	Yes
6x350 LP	No	Yes	Yes	No	Yes	No	No	Yes

Technical data for DULCODES LP

Type	Max. flow rate	Lamp power	Connected load	Radiation chamber length	Free space needed for maintenance	Diameter	Connector width*
	m ³ /h	W	W	mm	mm	mm	DIN / ANSI / TC
1x80 LP	8.8	81	110	872	973	140	RP 2" / RP 2" / -
1x230 LP	35	260	310	1151	1064	140	DN 80 / 3" / DN 80
1x350 LP	53	370	430	1640	1465	168	DN 100 / 4" / DN 100
2x350 LP	123	2x370	835	1640	1465	256	DN 150 / 6" / DN 150
3x230 LP	155	3x260	825	1185	1156	324	DN 150 / 6" / -
3x350 LP	232	3x370	1,240	1885	1565	324	DN 200 / 8" / DN 200
4x350 LP	317	4x370	1,645	1885	1565	356	DN 200 / 8" / -
6x350 LP	523	6x370	2,455	1885	1565	406	DN 250 / 10" / -

* TC = Tri Clamp

Lamp type	Low-pressure lamp VARIO Flux
Control type	Comfort controller, optionally compact controller
Permissible operating pressure	10 bar or 16 bar
Ambient temperature	5–40 °C with comfort control, 5–35 °C with compact control
Permissible water temperature	2...70 °C
Enclosure rating	IP 66

Low-pressure lamp VARIO Flux (see page → 7)

Spare Parts For DULCODES LP UV Systems

	Order no.
UV lamp VARIO Flux 80 W	1061751
UV lamp VARIO Flux 230 W	1061752
UV lamp VARIO Flux 350 W	1061418
Lamp protection tube for UV system DULCODES 1x80 LP	1059182
Lamp protection tube for UV system DULCODES 1x230 LP	1107758
Lamp protection tube for UV systems DULCODES 1x350 LP and 2x350 LP	1107757
Lamp protection tube for UV systems DULCODES 3x350 LP to 6x350 LP	1107756
O-ring lamp protection tube/lamp cover for UV system DULCODES 1x80 LP	1004920
O-ring lamp protection tube/lamp cover for UV systems DULCODES 1x230 LP to 6x350 LP	1023569
UVC sensor	1075544
Screwed plug G 1/2" for UV systems DULCODES 2x350LP to 6x350LP	1005818
Screwed plug G 1/4" for DULCODES UV systems 1x80 LP to 1x350 LP	1002752
O-ring for G 1/4" screwed plug for DULCODES UV systems 1x80 LP to 1x350 LP	1001356
O-ring for G 1/2" screwed plug for DULCODES UV systems 2x350 LP to 6x350 LP	1002279





1.1 UV Systems DULCODES

1.1.5 UV System DULCODES LP certified

Global first in the chemical-free disinfection of potable water – now also certified

Flow up to 406 m³/h



UV system DULCODES LP for drinking water disinfection, comprehensively certified to internationally-recognised DVGW/ÖVGW/SVGW/UVDGM standards. Looking to the future, the systems have already been type-tested in accordance with the latest DIN 19294-1:2020-08 test regulation. Successful certification officially confirms the precise 50-100% control range of the highly efficient VARIO-Flux lamps with dynamic lamp heating.



The DULCODES LP is the first UV system to be precisely controllable over a wide temperature range.

The unique combination of electronic ballast technology and the VARIO-Flux lamps enables the system to be quickly and precisely dimmed over a broad capacity range of up to 50%. It therefore automatically adapts to changing flows or changes in water temperature.

Maximum efficiency and minimal life cycle costs are therefore achieved due to the reduced number of lamps and minimal use of energy.

Optimum flow in the reactors is based on intensive computer simulations. The radiation dose of a partial volumetric flow is even without over-metering or under-metering. At the same time the pressure loss is kept to a minimum.

Your Benefits

- Unique dynamic lamp heating adjusts the lamp output in seconds and provides for optimum disinfection even with varying flows and water temperatures
- Homogeneous UV dose thanks to optimised flow behaviour in the reactor guarantees maximum flow output with a minimum number of lamps and minimum pressure loss
- Reduced life cycle costs: use of long-life VARIO-Flux high output lamps with low energy consumption and high UV yield
- Excellent flexibility: vertical or horizontal installation and free choice of flange position
- Control cabinet with efficient recirculation cooling ensures the long life of electronic components and protects against corrosion in aggressive ambient conditions
- System monitoring in real time from any location via the DULCONNEX Platform: Improved process reliability. Reliability and transparency thanks to real-time monitoring, individual alarms and automated reports.
- User-friendly and intuitive: the control for displaying operating statuses and adjusting operating parameters
- Precise documentation: all relevant operating data and events are saved on the SD card and can be simply and conveniently visualised with an analysis programme



Technical Details

- High-grade stainless steel 1.4404/316L reactor hydraulically optimised by means of computer simulation
- High-output amalgam lamps “VARIO-Flux” with dynamic lamp heating
- Guaranteed lamp service life of 14,000 operating hours (pro rata)
- Electronic ballasts for gentle lamp ignition, operation and individual monitoring as well as control
- DVGW/ÖVGW UVC sensor 160° opening angle, highly selective and age-stable, integrated in the measuring window
- Continuous monitoring of the reactor temperature by temperature sensor Pt 1000
- Single-lamp system: equipped with either a Compact controller or Comfort controller
- Various options for simple integration of the system in higher-level control systems thanks to many analogue and digital interfaces and connectors
- Data logger: all relevant operating data and events are saved on the SD card and can be simply and conveniently visualised with an analysis programme

Field of Application

- Potable water treatment
- Food and beverage production

1.1 UV Systems DULCODES

Design versions

The certified DULCODES LP systems are available in the following design versions:

Type	Compact controller	Comfort controller	Lamp dimming	Wiper	Stainless steel control cabinet	AC control cabinet	UL/ CSA-compliant
1x80 LP	Yes	No	No	No	No	No	No
1x230 LP	Yes	Yes	Yes	No	Yes	Yes	Yes
1x350 LP	Yes	Yes	Yes	No	Yes	Yes	Yes
2x350 LP	No	Yes	Yes	No	Yes	Yes	Yes
3x230 LP	No	Yes	Yes	No	Yes	Yes	Yes
3x350 LP	No	Yes	Yes	No	Yes	Yes	Yes
4x350 LP	No	Yes	Yes	No	Yes	No	Yes
6x350 LP	No	Yes	Yes	No	Yes	No	Yes

Technical data for DULCODES LP certified

Type	Max. flow rate*	Lamp power	Connected load	Radiation chamber length	Free space needed for maintenance	Diameter	Connector width**
	m ³ /h	W	W	mm	mm	mm	DIN / ANSI / TC
1x80 LP	6.4	81	110	872	973	140	RP 2" / RP 2" / -
1x230 LP	20.7	260	310	1151	1064	140	DN 80 / 3" / DN 80
1x350 LP	48	370	430	1640	1465	168	DN 100 / 4" / DN 100
2x350 LP	109	2x370	835	1640	1465	256	DN 150 / 6" / DN 150
3x230 LP	86	3x260	825	1185	1156	324	DN 150 / 6" / -
3x350 LP	168	3x370	1,240	1885	1565	324	DN 200 / 8" / DN 200
4x350 LP	251	4x370	1,645	1885	1565	356	DN 200 / 8" / -
6x350 LP	406	6x370	2,455	1885	1565	406	DN 250 / 10" / -

* 98 %/cm transmission; flows certified to DIN-DVGW 19294 / ÖNORM / SVGW / ACS

** TC = Tri Clamp

Lamp type	Low-pressure lamp VARIO Flux
Control type	Comfort controller, optionally compact controller
Permissible operating pressure	10 bar or 16 bar
Ambient temperature	5–40 °C with comfort control, 5–35 °C with compact control
Permissible water temperature	2...70 °C
Enclosure rating	IP 66

Low-pressure lamp VARIO Flux (see page → 7)

Spare Parts For DULCODES LP UV Systems

	Order no.
UV lamp VARIO Flux 80 W	1061751
UV lamp VARIO Flux 230 W	1061752
UV lamp VARIO Flux 350 W	1061418
Lamp protection tube for UV system DULCODES 1x80 LP	1059182
Lamp protection tube for UV system DULCODES 1x230 LP	1107758
Lamp protection tube for UV systems DULCODES 1x350 LP and 2x350 LP	1107757
Lamp protection tube for UV systems DULCODES 3x350 LP to 6x350 LP	1107756
O-ring lamp protection tube/lamp cover for UV system DULCODES 1x80 LP	1004920
O-ring lamp protection tube/lamp cover for UV systems DULCODES 1x230 LP to 6x350 LP	1023569
UVC sensor	1076149
Screwed plug G 1/2" for UV systems DULCODES 2x350LP to 6x350LP	1005818
Screwed plug G 1/4" for DULCODES UV systems 1x80 LP to 1x350 LP	1002752
O-ring for G 1/4" screwed plug for DULCODES UV systems 1x80 LP to 1x350 LP	1001356
O-ring for G 1/2" screwed plug for DULCODES UV systems 2x350 LP to 6x350 LP	1002279





1.1 UV Systems DULCODES

1.1.6 UV System DULCODES LP F&B

Chemical-free disinfection of production water for the food and beverage industry

Flow up to 168 m³/h



UV system with hygienic design of radiation chamber. For reliable disinfection and constant quality in your production process.



Pioneering water treatment – highly efficient UV system DULCODES LP F&B with VARIO-Flux lamp and dynamic lamp heating. The reduced number of lamps and minimal use of energy deliver maximum efficiency and minimal operating costs.

Optimised flow in the radiation chamber results in an even dose of radiation across the entire volumetric flow. At the same time the pressure loss is kept to a minimum.

The DULCODES LP F&B is the first UV system to be quickly and precisely controllable over a wide temperature range. It automatically adapts to changing flows or changes in water quality.

Your Benefits

- Efficient, safe and chemical-free disinfection of product water in the food and beverage industry
- Hygienic design without gaps and dead space, tri-clamp connectors, surface roughness Ra <0.8 internal and external, FDA-compliant materials
- Adapted disinfection with varying flows and water temperatures
- Increased flow output with a minimum number of lamps and minimum pressure loss
- Reduced operating costs due to the long-life VARIO-Flux high-output lamps with low energy consumption and high UV yield
- System monitoring in real time from any location via the DULCONNEX Platform: Improved process reliability. Reliability and transparency thanks to real-time monitoring, individual alarms and automated reports.
- User-friendly and intuitive control for displaying operating statuses and adjusting operating parameters
- Excellent flexibility thanks to vertical or horizontal installation and free choice of the flange position
- End-to-end documentation: all relevant operating data and events are saved on the SD card and can be simply and conveniently visualised with an analysis programme



Technical Details

- Comprehensively certified to internationally recognised DIN-DVGW / ÖNORM / SVGW / ACS / EPA-UVDGM standards.
- The unique combination of electronic ballast technology and the VARIO-Flux lamps enables the system to be quickly and precisely dimmed over a broad capacity range of up to 50%.
- Stainless steel control cabinet with IP 66 degree of protection.
- Suitable for integration into CIP (cleaning in place) circuits.
- High-grade stainless steel 1.4404/316L reactor hydraulically optimised by means of computer simulation.
- High-output amalgam lamps “VARIO-Flux” with dynamic lamp heating.
- Guaranteed lamp service life of 14,000 operating hours (pro rata).
- Electronic ballasts for gentle lamp ignition, operation and individual monitoring as well as control.
- DIN DVGW/ÖVGW UVC sensor 160° opening angle, highly selective and age-stable, integrated in the measuring window.
- Various options for simple integration of the system in higher-level control systems thanks to many analogue and digital interfaces and connectors.
- Data logger: all relevant operating data and events are saved on the SD card and can be simply and conveniently visualised with an analysis programme.

Field of Application

- Food and beverage production

1.1 UV Systems DULCODES

Technical data for DULCODES LP F&B

Type	Max. flow rate*	Lamp power	Connected load	Radiation chamber length	Free space needed for maintenance	Diameter	Connector width
	m ³ /h	W	W	mm	mm	mm	Tri clamp
1x350 LP	48	370	430	1640	1465	168	DN 100
2x350 LP	109	2x370	835	1640	1465	256	DN 150
3x350 LP	168	3x370	1,240	1885	1565	324	DN 200

* 98 %/cm transmission; flows certified to DIN-DVGW 19294 / ÖNORM / SVGW / ACS

Lamp type	Low-pressure lamp VARIO Flux
Control type	Comfort controller
Permissible operating pressure	10 bar
Min. ambient temperature	5 °C
Max. ambient temperature	40 °C
Permissible water temperature	2...70 °C
Enclosure rating	IP 66

Low-pressure lamp VARIO Flux (see page → 7)





1.1 UV Systems DULCODES

1.1.7 UV System DULCODES LP-PE

Chemical-free and reliable disinfection of water containing salt, such as seawater or thermal water.

Flow up to 505 m³/h



Disinfection of saline/seawater or thermal water with corrosion-resistant reactor the UV system DULCODES LP-PE. The UV system consists of a reactor and a UV sensor made of highly UV-resistant plastic.



The UV system DULCODES LP-PE plastic is absolutely corrosion-free. This is ensured by the UV-stabilised, highly compressed HD-PE reactor and a special sensor made of plastic. Thanks to a special welding process, the reactor is temperature-resistant and optimised to a pressure rating of up to 4 bar. Our patented VARIO Flux high-output lamps with dynamic lamp heating are used in our LP-PE systems. We achieve an extremely high UVC efficiency thanks to the unique combination of electronic ballast technology and the VARIO Flux lamps.

Your Benefits

- Reactor made of UV-stabilised high-density HD-PE, absolutely corrosion-free and temperature stable
- Long-term salt water-resistant UVC sensor for monitoring the disinfection capacity, contamination of the lamp protection tubes, lamp ageing and water transmission
- Highly efficient VARIO Flux 350 W lamps provide for maximum disinfection and flow rate with a minimum number of lamps.
- Electronic ballasts for gentle lamp ignition, operation and individual monitoring
- Replacement lamps are reduced to the absolute minimum
- System monitoring in real time from any location via the DULCONNEX Platform: Improved process reliability. Reliability and transparency thanks to real-time monitoring, individual alarms and automated reports
- Low maintenance costs and low follow-on costs as there are fewer, high-performance lamps featuring amalgam technology with an excellent service life of up to 14,000 hours
- Excellent flexibility thanks to vertical or horizontal installation
- Data logger: all relevant operating data and events are saved on the SD card and can be simply and conveniently visualised with an analysis programme



Technical Details

- Reactor made of UV-stabilised high-density HD-PE
- High-performance and highly efficient low-pressure amalgam lamps VARIO Flux with dynamic lamp heating
- Guaranteed (pro rata) lamp service life: 14,000 hours of operation
- Long-term stable UVC sensor made of PTFE for continuous monitoring of the system, factory-calibrated in accordance with the DVGW standard.
- Control cabinet made of coated steel
- Single-lamp system: equipped with either a Compact controller or Comfort controller UVCb
- Various options for simple integration of the system in higher-level control systems thanks to many analogue and digital interfaces and connectors
- Data logger: all relevant operating data and events are saved on the SD card and can be simply and conveniently visualised with an analysis programme.

Field of Application

- Process water
- Swimming pool water
- Salt water

1.1 UV Systems DULCODES

Technical data for DULCODES LP-PE plastic

Type	Max. flow rate	Lamp power	Connected load	Radiation chamber length	Free space needed for maintenance	Diameter	Connector width
	m ³ /h	W	W	mm	mm	mm	DIN / ANSI
1x350 LP-PE	35	1x370	430	1590	1565	140	DN 80
2x350 LP-PE	123	2x370	835	1590	1565	280	DN 125
3x350 LP-PE	252	3x370	1,240	1590	1565	400	DN 200
4x350 LP-PE	328	4x370	1,645	1590	1565	400	DN 200
6x350 LP-PE *	505	6x370	2,455	1590	1565	500	DN 300

* permissible operating pressure 3 bar

Lamp type	Low-pressure lamp VARIO Flux
Control type	Comfort controller, optionally compact controller
Permissible operating pressure	4 bar
Ambient temperature	5–40 °C with comfort control, 5–35 °C with compact control
Permissible water temperature	5...30 °C
Enclosure rating	IP 66

Low-pressure lamp VARIO Flux (see page → 7)

Spare parts for DULCODES LP-PE UV systems

	Order no.
UV lamp VARIO Flux 350 W	1061418
Lamp protection tube for DULCODES LP-PE systems	1026694
O-ring lamp protection tube/lamp cover for UV systems DULCODES 1x230 LP to 6x350 LP	1023569
O-ring lamp cover	1006332
O-ring sensor K, PTFE	1035201
O-ring for UVC sensor K, PTFE	1041049



1.1 UV Systems DULCODES

1.1.8 UV System DULCODES LP TL

Efficient UV disinfection of sugar syrup

Flow up to 36 m³/h



The UV system DULCODES LP TL for syrup disinfection declares war on heat-resistant germs. In instances when standard heat pasteurisation isn't up to the job, UV light provides a very quick and efficient form of disinfection without the need for heat.



The UV system DULCODES LP TL can disinfect up to 36 m³/h of sugar syrup. The system uses an optimised flow with mixing zones in the thin-film reactors for optimum radiation of liquids. When working with viscous media with a low UV transmission of up to 20 %/cm in particular, UV disinfection saves energy and costs and can replace pasteurisation. Up to 99.99 % of heat-resistant spores can be eliminated which typically cannot be achieved by pasteurization. UV treatment with the DULCODES LP TL system has no negative impact on the quality, taste or appearance of the sugar syrup.

Your Benefits

- Reliable elimination of spores, yeasts and mould fungus, especially 99.99 % of heat-resistant spores
- Product quality is unchanged in terms of appearance, taste and aroma
- Saves energy and money because the UV system takes the place of standard, energy-intensive pasteurisation
- Low investment costs
- Hygienic system design: no dead space, surface finishing < 0.8µm, residual emptying possible, round tubular frame, hygienic design of the control cabinet, etc.
- Remote control: simple remote monitoring and remote control
- Optimised flow behaviour ensures even UV radiation of all medium with one UV dose
- Continuous monitoring of system performance by DVGW/ÖVGW-compliant sensor connection system with calibrated UVC sensor
- Reduced life cycle costs: Use of long-life VARIO-Flux high output lamps with low energy consumption and high UV yield
- Turnkey system into which numerous options can be integrated: Pre-filtration and post-filtration, pressure sensors, temperature sensors, IDM flow measurement, butterfly valves for shutting off, sample valves for microbiological testing, control cabinet air conditioning
- Mapping of the UV dose applied, in conjunction with a flow measurement
- User-friendly and intuitive: the control for displaying operating statuses and adjusting operating parameters by means of a clear touch panel
- Precise documentation: all relevant operating data and events are saved and can be simply and conveniently analysed

Technical Details

- Hydraulically optimized reactor made of high-quality stainless steel 1.4404/AISI316L using computer simulation
- High-performance amalgam lamps 'VARIO-Flux' with dynamic lamp heating
- Guaranteed lamp life of 14,000 operating hours (pro rata)
- Electronic ballasts for gentle ignition, operation and individual monitoring as well as control of the lamps

Field of Application

- Disinfection of sugar syrup



1.1 UV Systems DULCODES

Technical data for DULCODES LP TL

	Max. flow rate* m ³ /h	Max. flow rate** m ³ /h	Lamp power W	Connected load kW	Dimensions L x W x H mm
2x350 LP TL	4	2.3	2x370	1.4	2,700 x 600 x 2,300
4x350 LP TL	8	4.6	4x370	2.0	2,700 x 600 x 2,300
6x350 LP TL	12	6.9	6x370	2.9	2,700 x 600 x 2,300
2 x 4x350 LP TL	16	9.2	8x370	3.4	2,700 x 800 x 2,300
2 x 6x350 LP TL	24	13.8	12x370	5.4	2,700 x 800 x 2,300
3 x 6x350 LP TL	36	20.7	18x370	7.5	3,000 x 1,300 x 2,300

* UV transmission > 38 %/cm; irradiation intensity 1.300 J/m²

** UV transmission > 20 %/cm; irradiation intensity 1.300 J/m²

Lamp type	Low-pressure lamp VARIO Flux
Control type	Siemens SPS with touch panel
Permissible operating pressure	10 bar
Permissible ambient temperature	5...40 °C
Permissible medium temperature	4...40 °C
Enclosure rating	IP54

1.1 UV Systems DULCODES

1.1.9 UV System DULCODES MP

Effective solution for the treatment of swimming pool water – designed for the decomposition of combined chlorine.

Flow up to 853 m³/h



The UV system DULCODES MP is used for the efficient breakdown of combined chlorine in swimming pools, eliminating the typical swimming pool odour: no more irritation for eyes, nose and skin. Apart from improving the water quality, the lower investment costs and high fresh water and energy consumption savings result in shorter payback times.

The UV system DULCODES MP is fitted with output-optimised medium-pressure lamps. They guarantee the efficient photochemical breakdown of combined chlorine in swimming pool water. The system features no sensitive, electronic components and instead relies on proven and robust technology.

Efficient cleaning of the lamp protection tubes during operation is possible with ease. The lamp protection tubes can either be cleaned by a manual wiper or by the motor-driven automatic wiper, which can be added as an option.

The DULCODES MP is a compact inline system. Thanks to its flexible flange options, the system can be used with ease for different nominal widths of circulation rate. The UV reactor is designed in such a way that no UV radiation can escape from the reactor. This means that the system can be installed directly in a plastic pipe. The free choice of the fitting position simplifies installation and retrofitting in the extreme.



Your Benefits

- Simple installation, thanks to the compact inline system, ensures minimal installation work and fast retrofitting
- Maximum flexibility when installing thanks to the free choice of fitting position and direct installation in plastic pipes as no UV radiation escapes from the reactor
- Automatic chloramine value-dependent On/Off switching of the UV system, e.g. in combination with DULCOMARIN
- Unbeatably simple and quick maintenance: all maintenance work can be carried out quickly and conveniently from one side
- Manual power control for optimum adaptation of the system to the respective capacity requirement (not for DULCODES 1 x 0.65MP and 1MP)
- System monitoring in real-time from any location via the DULCONNEX Platform: Improved process reliability. Reliability and transparency thanks to real-time monitoring, individual alarms and automated reports

Technical Details

- Manual or automatic wiper system for the efficient removal of deposits on the lamp protection tube. The wiper system can be easily retrofitted
- Integral temperature switch to monitor the water temperature in the radiation chamber
- Compliance with DIN 19643 and recommended for use in swimming pools
- Optimised use of energy thanks to large radiation chamber and uniform irradiation of the entire water flow due to optimised system hydraulics
- Radiation chambers made of high-grade stainless steel 1.4404/AISI316L
- Long-term stable UVC sensor for monitoring the lamp output, dirt on the lamp protection tube and changes in water quality
- Powerline medium-pressure lamps with high connecting power of up to 3 kW
- Manual or automatic motor-driven wiper for the efficient removal of deposits on the lamp protection tube
- Guaranteed (pro rata) lamp service life of 8000 hours
- Comfort controller with various options for simple integration of the system in higher-level control systems thanks to many analogue and digital interfaces and connectors
- Control cabinet made of coated steel

Field of Application

- Process water
- Swimming pool water



1.1 UV Systems DULCODES

Technical data for DULCODES MP

Type	Max. flow rate	Lamp power	Connected load	Radiation chamber length	Free space needed for maintenance	Empty weight/ Operating weight	Connector width
	m ³ /h	W	kW	mm	mm	kg	DIN / ANSI
1x0.65 MP	20.0*/30**	650	0.75	500	335	21/31	DN 65/80
1x1 MP	58.0*/87**	1.000	1.10	700	400	31/47	DN 100/125
1x2 MP	102.0*/153**	2.000	2.10	700	500	38/65	DN 125/150
1x3 MP	205.0*/308**	3.000	3.20	800	600	52/118	DN 200/250
2x2 MP	278.0*/417**	4.000	4.20	900	1000	78/166	DN 200/250
2x3 MP	379.0*/568**	6.000	6.20	900	1000	78/166	DN 250
3x3 MP	569.0*/853**	9.000	9.20	900	1000	78/166	DN 250/300

* 98%/cm transmission; 600 J/m² irradiation intensity for the breakdown of combined chlorine

** 98%/cm transmission; 400 J/m² irradiation dose for disinfection applications

Lamp type	Powerline medium-pressure lamp
Control type	Comfort controller
Permissible operating pressure	6 bar
Permissible ambient temperature	5...40 °C
Permissible water temperature	5...40 °C
Enclosure rating	IP54

Powerline medium-pressure lamp (see page → 7)

Spare parts for DULCODES MP UV systems

	Order no.
Powerline UV lamp 1 kW	1035179
Powerline UV lamp 2 kW	1035057
Powerline UV lamp 3 kW	1035180
Lamp protection tube for DULCODES 1 A and 0.6 MP	1035218
Lamp protection tube for DULCODES 1 MP	1035166
Lamp protection tube for DULCODES 2 MP	1035041
Lamp protection tube for DULCODES 1 x 3 MP, 2 x 2 MP, 2 x 3 MP, 3 x 3 MP	1035193
Wiper element	1027879
Spare parts kit UV MP 1 – 3 kW motor wiper	1060734
Spare parts kit UV MP 2x2 kW and 2x3 kW motor wiper	1060737
Spare parts kit UV MP 3x3 kW motor wiper	1060738
O-ring lamp protection tube/lamp cover	790410
UVC-U sensor	1080715
Sensor connection cable, 5 m long for systems supplied since September 2006	1021041
Replacement filter mats for control cabinet ventilation (2 off required per control cabinet)	1004212





1.1 UV Systems DULCODES

1.1.10

UV System DULCODES A

Perfect for the treatment of higher flows.

Flow up to 809 m³/h



The UV system works cleanly and with efficient use of energy, based on continuously variable medium pressure lamps, and can therefore automatically compensate for variations in the water quality or level of contamination.



For the disinfection of drinking water, elimination of chlorine, chlorine dioxide and ozone, or for the breaking down of combined chlorine in swimming pool water. The Powerline medium-pressure lamps safely inactivate pathogenic organisms. In particular, chlorine-resistant germs, such as cryptosporidia or giardia, are reliably eliminated.

The system is equipped with electronic ballasts, which continuously adjust the lamp output, either via an external signal, such as the flow rate, or by specification of a setpoint.

A long-term stable UVC sensor ensures that the system operates safely and reliably. The motor-driven automatic wiper efficiently cleans the lamp protection tubes and minimises maintenance work with types of water that have a tendency to form films. After comprehensive certification and biodosimetric validation, the systems comply with strict internationally recognised NSF, UL, CSA and USEPA standards.

Your Benefits

- Simple installation, thanks to the compact inline system, ensures minimal installation work and fast retrofitting
- Maximum flexibility when installing thanks to the free choice of fitting position and direct installation in plastic pipes as no UV radiation escapes from the reactor
- External power control via 0/4 - 20 mA standard signal for optimum adaptation of the system to changing operating conditions, such as flow fluctuations
- Automatic adjustment of the lamp output to a defined UVC sensor signal with an increase in power to a raised, adjustable sensor signal via a digital input saves energy and extends the lamp service life.
- Unbeatably simple and quick maintenance: all maintenance work can be carried out quickly and conveniently from one side.
- Certified systems: NSF 50, CSA 22, UL508, comprehensively biodosimetric validated to UVDGM 2006

Technical Details

- Radiation chambers made of high-grade stainless steel 1.4404/AISI316L
- Guaranteed (pro rata) lamp service life of 8000 hours
- UVC sensor with long term stability to monitor the system output
- Automatic motor-driven wiper for efficient removal of deposits on the lamp protection tube
- Freely programmable control with backlit display during normal operation (green), warning (yellow) and fault (red), visible from afar too
- Minimum pressure losses even with high flow volumes
- Optimised use of energy thanks to large radiation chamber and uniform irradiation of the entire water flow due to optimised system hydraulics.
- Powerline A medium-pressure lamp with high connecting power of up to 3 kW
- Integral temperature sensor for monitoring the water temperature in the radiation chamber
- Double, independent and automatic monitoring of the wiper function by revolution counter and limit switch
- Control cabinet made of coated steel
- Large graphic display to show all important operating parameters, such as the UV sensor signal, lamp power consumption, control type and operating status
- Interfaces and connectors for:
 - Shut-off and rinse valve
 - Control of the feed pump
 - Operating signal relay
 - Warning and alarm relay for UV intensity
 - Collective malfunction alert relay
 - Pause contact
 - Relay for monitoring reactor temperature
 - Temperature monitoring and fault indicating relay for control cabinet temperature
 - Input for external fault
 - Digital input for switch-over to second power stage
 - 4-20 mA standard signal input for flow-dependent lamp control or control dependent on measured value
 - Standard signal output 4-20 mA of UV sensor signal

NSF 50

UVDGM 2006

UL-CSA

1.1 UV Systems DULCODES

Field of Application

- Potable water
- Process water
- Swimming pool water

1



1.1 UV Systems DULCODES

Technical data for DULCODES A

Type	Max. flow rate	Lamp power	Connected load	Radiation chamber length	Free space needed for maintenance	Min. distance from wall	Empty weight/ Operating weight	Connector width
	m ³ /h	W	kW	mm	mm	mm	kg	DIN / ANSI
1x1 A	50*/83**	1.000	1.10	700	400	300	31/47	DN 100/4"
1x2 A	91*/149**	2.000	2.10	700	500	300	38/65	DN 150/6"
1x3 A	176*/290**	3.000	3.20	800	600	300	52/118	DN 200/8"
2x2 A	240*/395**	4.000	4.20	900	1000	300	78/166	DN 200/8"
2x3 A	328*/539**	6.000	6.20	900	1000	300	78/166	DN 250/10"
3x3 A	492*/809**	9.000	9.20	900	1000	300	78/166	DN 300/12"

* 98%/cm transmission; 600 J/m² irradiation intensity for the breakdown of combined chlorine

** 98%/cm transmission; 400 J/m² irradiation dose for disinfection applications

Lamp type	Powerline A medium-pressure lamp
Permissible operating pressure	10 bar for single-lamp systems 1 x 1A - 1 x 3A 7 bar for multiple-lamp systems 2 x 2A - 3 x 3A
Permissible ambient temperature	5...40 °C
Permissible water temperature	5...40 °C
Enclosure rating	IP54

Powerline medium-pressure lamp (see page → 7)

Accessories for DULCODES 1 x 1 A, 1 x 2 A and 1 x 3 A

	Order no.
25 m cable set including cables for lamp, UV sensor, Pt1000, limit switch and safety switch	1106743

Spare Parts for DULCODES A UV Systems

	Order no.
Powerline UV lamp 1 kW	1035179
Powerline UV lamp 2 kW	1041450
Powerline UV lamp 3 kW	1041451
Lamp protection tube for DULCODES 1 A and 0.6 MP	1035218
Lamp protection tube for DULCODES 2 A	1041723
Lamp protection tube for DULCODES 3 A	1041485
Wiper element	1027879
Spare parts set for UV A 1-3 kW motor wiper	1042860
Spare parts kit UV MP 2x2 kW and 2x3 kW motor wiper	1044862
Spare parts kit UV MP 3x3 kW motor wiper	1044863
O-ring lamp protection tube/lamp cover for UV systems DULCODES 1x230 LP to 6x350 LP	1023569
UVC-U sensor M -1, 4-20 mA	1080714
Replacement filter mats for control cabinet ventilation (2 off required per control cabinet)	1004212



1.1 UV Systems DULCODES

1.1.11

Accessories for DULCODES UV Systems

1/2" drain kit for DULCODES LP systems

2 no. 1/2" stainless steel ball valves and connecting material for direct connection to the reactor for drainage and bleeding.

	Order no.
1/2" drain kit for DULCODES 3x350LP to 6x350LP	1075776

Transmission Photometer UVT P200

Photometer for measuring 254 nm UV transmission.

Supplied in stable, compact, water-tight plastic box including 10 mm quartz cuvette. Storage of the in-situ calibration means that a calibration using deionised water prior to every calibration is not necessary.

Dimensions L x W x H	230 x 190 x 95 mm
Weight	1.8 kg
Voltage supply	100 - 240 V AC 50/60 Hz, 12 V DC auto-adapter
UV-C lamp	Mercury low-pressure lamp
Measuring resolution	Transmission in 0.1%
Measuring accuracy	Transmission in $\pm 0.5\%$
Measuring range	5 – 100%/cm

	Order no.
Transmission Photometer UVT P200	1045245

Reference radiometer RRM

Reference radiometer for checking certified UV systems DULCODES LP. The portable instrument is fitted with an insertion sensor which is used for measurement of the radiation intensity without operational interruption directly in the radiation chamber of the DULCODES LP in place of the unit sensor. Suitable UV protective glasses should be worn as UV radiation escapes from the radiation chamber during this procedure.

Measuring range	20/200/2,000/20,000 W/m ² (switchable)
Display	3-digit
Voltage supply	Battery, 9 V Type 6F22 or equivalent

	Version	Order no.
for measuring field angle 40°	for measuring field angle 40°	1025094
for measuring field angle 160°	for measuring field angle 160°	1076575
for measuring field angle 40° and 160°	for measuring field angle 40° and 160°	1076576

UV protective glasses

Protective glasses to protect against UV radiation that may be harmful to the eye when working on open UV systems.

	Order no.
UV protective glasses	1025243

Protective gloves

Protective gloves made of white cotton to avoid fingerprints on UV lamps and lamp protection tubes. 1 pair in universal size.

	Order no.
Protective gloves	1032815

Sampling valve

	Order no.
Sampling valve	1074593





1.1 UV Systems DULCODES

Cleaning system

Cleaning system for flushing the radiation chamber with a cleaning concentrate to remove deposits on the lamp protection tubes and internal surfaces of the UV system. Consists of chemical tanks, feed and metering pumps, valves and complete automatic or manual controller. Design and technical equipment are matched to the particular UV system and its application.

	Order no.
Cleaning system	on request

Fittings

Fittings provided for quick and easy wall mounting of the UV radiation chamber. Fitting parts comprise 2 screw-in pipe clips in high alloy steel (V2A), 2 base plates with M12 nut, 2 set screws and 4 M12 hexagon nuts.

Two-part clip with increased material cross-section to ensure high bearing strength and breaking resistance. A soundproofing layer ensures marked resistance in the sound level.

	Type	Order no.
Fittings A2	1x80 LP, 1x230 LP	1039828
Fittings A2	1x350 LP, 3x230 LP	1077823
Fittings A2	2x350 LP	1077844

Overvoltage Protection

Overvoltage protection for DULCODES UV systems, which are run at 230 V 50 - 60 Hz.

The external overvoltage protection is intended for cases where the protection provided inside the unit is not sufficient for voltage surges of 1 kV between the conductors and 2 kV to earth. To protect systems on grids with high levels of interference energy, overvoltage protection can significantly improve the interference resistance of DULCODES systems as a precision protection measure.

Only an in-depth investigation into the voltage circumstances on-site can establish whether further measures, such as medium-level or broad-based protection, are needed in addition to precision protection.

	Order no.
Fine protection PT 2-DE IS 230 IAC	733010

Replacement Plug-in Insert After Tripping

	Order no.
Replacement plug-in insert PT 2-DE / S 230 / AC - ST	733011

Clip-on thermostat for systems with compact control

	Order no.
Clip-on thermostat 30-90 °C 230 VAC	1043944

1.2 Ozone Systems OZONFILT and DULCOZON

1.2.1 Ozone in Water Treatment

As the most powerful oxidant that can be used in water treatment, ozone permits a broad spectrum of possible applications:

Outstanding disinfection action against

- Germs and viruses
- Fungi and parasites

Oxidation of undesirable inorganic substances in the water

- Iron and manganese
- Arsenic
- Nitrite and sulphide

Oxidation of undesirable organic substances in the water

- Strong-smelling and strong-tasting compounds
- Humic substances and other compounds which affect the colour of the water
- Cyclic hydrocarbons
- Trihalomethanes, chloramines and other chlorine compounds

Micro-flocculating action

- After oxidation with ozone, substances and colloids dissolved in the water become insoluble and can be filtered

Significantly fewer undesirable by-products result from the generation and use of ozone than with other comparable oxidants and disinfectants. As a highly reactive gas, ozone is generated on-site from oxygen and introduced to the water directly without interim storage. Because of its high reactivity, ozone decomposes into oxygen again in the water, with a half-life of several minutes. Therefore all the components of an ozone treatment system have to be perfectly coordinated with one another and the planned application to achieve an optimum relationship between ozone generation and its effect.

For every new project, our engineers draw on the experience that we have been adding to since 1971. We have experience in the following applications:

Drinking water supply

- Oxidation of iron, manganese or arsenic
- Refinement and improvement of taste
- Disinfection

Food and beverage industry

- Disinfection of table water
- Disinfection of rinsers in the beverage industry
- Disinfection of production water

Swimming pools

- Reduction of chloramines and trihalomethanes, avoiding typical swimming pool odours
- Crystal clear water thanks to micro-flocculating action
- Reliable microbiological barriers in therapy pools
- Reduction in investment and operating costs through scope for reducing the circulating power and throttling the fresh water inlet

Industry

- Cooling water treatment
- Combating legionella in cooling water circuits
- Disinfection of process water
- Removal of odorous substances in air scrubbers





1.2 Ozone Systems OZONFILT and DULCOZON

Municipal wastewater treatment

- Elimination of micropollutants
- Reduction of clarifier sludge
- COD reduction/breakdown
- Removal of colour

1.2 Ozone Systems OZONFILT and DULCOZON

1.2.2 Performance Overview of Ozone Systems

ProMinent ozone systems work on the proven principle of silent electrical discharge. Ozone is produced from oxygen between two electrodes separated by an insulating dielectric by applying a high voltage of several thousand volts. Depending on the system type, either dried ambient air or concentrated oxygen is used as the source of oxygen. ProMinent ozone systems are optimised to ensure maximum return and operating safety. They conform to the German DIN 19627 standard for ozone generation systems and are characterised by low energy and cooling water consumption.

Medium-frequency pressure systems

With the OZONFILT OZVb and OZMa product range, the air feed gas is fed to the ozone generator under pressure. With the DULCOZON OZLa product range, oxygen is used as the process gas. Ozone is generated using medium-frequency high voltage.

The use of an integrated pressure swing dryer and a dielectric with optimum thermal conductivity makes the system extremely compact.

Operation under pressure means that the ozone generated can be introduced directly into water systems with a back pressure of up to 4 bar with OZVb and up to 2 bar with OZMa and OZLa. Additional booster pumps and injectors can therefore be dispensed with in many applications.

ProMinent offers a wide range of ozone systems for the most diverse applications. The following overview shows the capacity ranges of our type series:

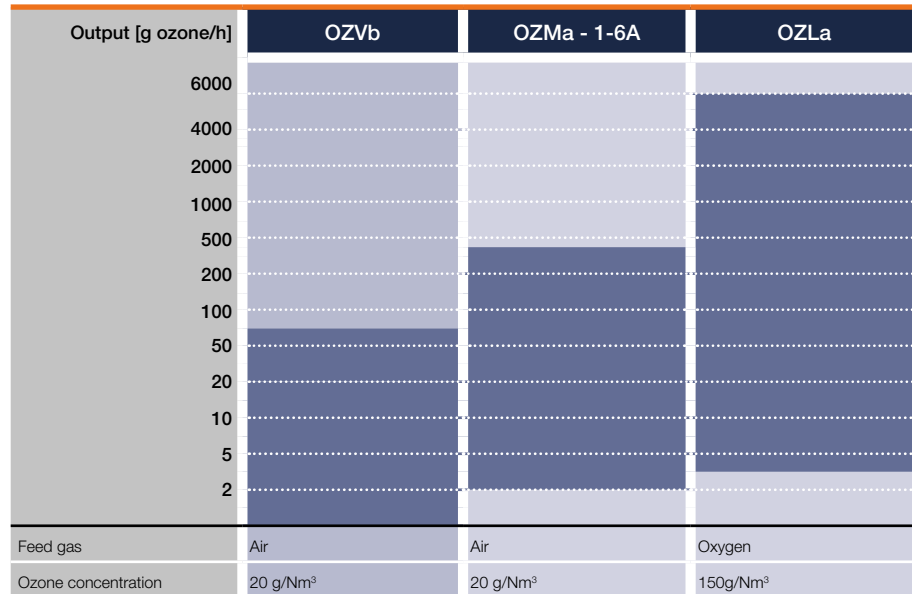

larger systems available on request

ProMinent provides all the advice needed for the safe operation of an ozone system:

- Evaluation of the situation on-site by trained, expert field sales staff.
- We can measure all key water parameters required for optimum system design in our water laboratory.
- Project planning of the system.
- Commissioning and system maintenance by our trained service technicians.





1.2 Ozone Systems OZONFILT and DULCOZON

1.2.3 Questionnaire on the Design of an Ozone System

Use of the ozone system:

- for treatment of
 - Drinking water
 - Product water in the food and beverage industry, cosmetics or pharmaceutical industry
 - Industrial water
 - Cooling water
 - Swimming pool water
 - Zoo
 - _____
- for oxidation of
 - Iron, manganese, nitrite, sulphide etc.
 - Organic matter
 - Discolouration
 - _____
- _____

Water values:

- | | | | |
|----------------------|-----------------------------------|---|--|
| Max. water flow rate | _____ m ³ /h | Maximum water pressure | _____ bar |
| Water flow rate | <input type="checkbox"/> constant | <input type="checkbox"/> fluctuating from | _____ m ³ /h to _____ m ³ /h |
| pH value | _____ | Iron (Fe ²⁺) | _____ mg/l |
| Temperature | _____ °C | Manganese (Mn ²⁺) | _____ mg/l |
| Solid fraction | _____ mg/l | Nitrite (NO ₂ ⁻) | _____ mg/l |
| | | Sulphide (S ²⁻) | _____ mg/l |
| | | TOC (total organic carbon) | _____ mg/l |

Response time to application:

_____ m³ volume reaction tank or _____ minutes residence time in entire system

Type of metering:

- constant
- flow-proportional
- depending on measured value

Desired amount of metering: _____ mg/l

Other requirements:

1.2 Ozone Systems OZONFILT and DULCOZON

1.2.4 Ozone System OZONFILT OZVb

Powerful and environmentally-friendly disinfection and oxidation

Ozone capacity 10 – 70 g ozone/h



OZONFILT OZVb is powerful and compact and is ideal for efficient ozone generation from compressed air in the output range of up to 70 g/h. The turnkey ozone system including mixing equipment offers everything you need for safe and seamless operation.



Ozone systems OZONFILT OZVb are pressurised systems in which compressed air is fed into the ozone generator.

The ozone is generated from the oxygen in the compressed air and simultaneously metered. The integrated air treatment system is designed as a pressure swing dryer. Ozone can therefore be generated safely and reliably even in difficult conditions with ozone concentrations of up to 20 g/Nm³. Ozone concentrations in the water to be treated of between 3 and 12 ppm can be achieved using our coordinated mixing equipment with an efficiency of up to 95%.

Legal notice for operating ozone systems in Europe:

For legally compliant operation of ozone systems in Europe, the system must be approved and/or registered in accordance with the Biocidal Products Regulation (EU) No. 528/2012. As a member of EurO₃zon, ProMinent automatically provides the necessary approval for biocidal applications in accordance with the Biocidal Products Regulation on behalf of its customers. For more information, see <https://www.prominent.de/resources/Other/German/26231/20210216-Kunden-Info-BPR-REACH.pdf>.

Your Benefits

- Safe and seamless operation through continuous monitoring of all relevant operating data
- Simple, safe and reliable operation with process visualisation thanks to colour and clear 4.3" touch panel
- Compact system with integral air treatment
- Turnkey complete system with perfectly coordinated mixing device including back pressure valve, vacuum breaker and static mixer
- Direct injection without injector system for up to 4 bar back pressure
- Low maintenance and operating costs thanks to maintenance-free generator concept and virtually infinite service life
- Maximum efficiency with minimal consumption of energy and cooling water
- Continuously variable and precise output control of between 3% and 100% of the nominal power with ozone volume displayed in "grammes/hour"
- Automatic adjustment of the performance data to fluctuations in mains voltage and pressure

Technical Details

- 4 different sizes depending on the capacity range
- Compact mounting in a painted steel cabinet
- Special dielectric with outstanding cooling performance: in spite of the low cooling water consumption, heat is quickly and efficiently discharged before the ozone produced can decompose due to excessive heat
- Integrated air treatment based on a pressure swing dryer with adjustable throttle valve and analogue flow measurement and pressure monitoring
- Continuous analogue pressure measurement in the ozone generator with automatic capacity adjustment to compensate for pressure fluctuations
- Cooling water system with automatic shut-off valve, adjustment valve and monitoring device via flow and temperature sensor
- Gas-tight diaphragm valve at the ozone outlet
- PLC control with operating data recorded on an SD card
- Simple, safe and reliable operation with process visualisation thanks to colour and clear 4.3" touch panel
- Contact inputs for external On/Off switching, gas detector connector, external fault alert, flow control
- Analogue input 4-20 mA for power control depending on the measured value combined with external measuring and control technology
- Contact outputs for common alarm message, warning and operation
- Wide range of communication interfaces for connection to higher-level controls or for remote monitoring (LAN web server, PROFIBUS® DP, PROFINET®, Modbus TCP or RTU)

1.2 Ozone Systems OZONFILT and DULCOZON

Options

- Stainless steel control cabinet
- Pressure controller with filter unit at the compressed air input
- Different designs of ready-wired installed mixing unit up to complete equipment including back pressure valve, vacuum breaker and integral static mixer
- Air conditioning: The system can be equipped with integrated air conditioning at ambient temperatures above 40 °C
- Control of a cooling water chiller
- Integration of a dew point sensor to monitor the quality of compressed air

Field of Application

- **Drinking water supply:** Oxidation of iron, manganese and arsenic, refinement and taste enhancement and disinfection
- **Food and beverage industry:** Oxidation of iron and manganese, disinfection of table water and rinsing water
- **Swimming pools:** Degradation of disinfection by-products, reliable microbiological barrier and production of crystal-clear water thanks to its microfloculating effect
- **Industry:** Legionella prevention and disinfection of cooling water

1.2 Ozone Systems OZONFILT and DULCOZON

OZONFILT ozone generation systems OZVb 1 – 4 (operating gas air)

Technical Data

Ambient parameters

Max. 85% air humidity of the ambient air, non-condensing, non-corrosive, dust-free, max. ambient temperature: 40 °C (with integrated air conditioning system: 50 °C)

		OZVb 1	OZVb 2	OZVb 3	OZVb 4
Number of modules		1	1	1	2
Ozone capacity, measured in accordance with DIN with air at 20 °C, cooling water at 15 °C	g/h	10	20	35	70
Ozone output max. 2.5 bar	g/h	8.0	16.0	28.0	56.0
Ozone output max. 3.0 bar	g/h	6.2	12.4	21.7	43.4
Ozone output max. 3.5 bar	g/h	4.4	8.8	15.4	30.8
Air consumption (only ozone generation)	Nm ³ /h	0.50	1.00	1.75	3.50
Ozone concentration in the gas phase referred to nominal conditions*	g/Nm ³	20	20	20	20
Specific energy requirement at nominal capacity	Wh/g	16.5	16.5	16.5	16.5

* Nm³ = m³ under normal [standard] conditions (p = 1.013 x 10⁵ Pa, T = 273 K)

Electrical Connection

		OZVb 1	OZVb 2	OZVb 3	OZVb 4
Mains connected load	V/Hz/A	230/50;60/2	230/50;60/6	230/50;60/6	230/50;60/10
Enclosure rating		IP54	IP54	IP54	IP54
Degree of protection with integrated air conditioning unit (internal/external)		IP 54 / IP 34	IP 54 / IP 34	IP 54 / IP 34	IP 54 / IP 34

Overall Dimensions (Without Mixer)

Wall-mounted cabinet with OZVb 1, 2 and 3 sizes; floor-mounted cabinet with OZVb 4 size

		OZVb 1	OZVb 2	OZVb 3	OZVb 4
Width	mm	760	760	800	800
Height	mm	760	760	1,000	1,200
Depth	mm	300	300	300	300

Weight

		OZVb 1	OZVb 2	OZVb 3	OZVb 4
Weight	kg	80	80	95	140

Ozone Mixing

		OZVb 1	OZVb 2	OZVb 3	OZVb 4
Max. raw water temperature	°C	35	35	35	35
Pressure at ozone output	bar	0.8...4.0	0.8...4.0	0.8...4.0	0.8...4.0

Air Supply

		OZVb 1	OZVb 2	OZVb 3	OZVb 4
Air demand	Nl/min	11.1	22	38	76
Air quality	oil and dust-free, non-corrosive, constant priming pressure of 4.5 – 10 bar, max. temperature 40 °C				





1.2 Ozone Systems OZONFILT and DULCOZON

Cooling Water

		OZVb 1	OZVb 2	OZVb 3	OZVb 4
Cooling water consumption (15 °C)	l/h	10	20	35	70
Cooling water inlet pressure	bar	1...5	1...5	1...5	1...5
Cooling water inlet		G 1/4" internal	G 1/4" internal	G 1/4" internal	G 1/4" internal
Cooling water outlet		G 1/4" internal	G 1/4" internal	G 1/4" internal	G 1/4" internal
Cooling water temperature at ambient temp. max. 35 °C	°C	30	30	30	30
Cooling water temperature at ambient temp. 35–40 °C	°C	25	25	25	25

Cooling water quality

No tendency to form lime scale, no corrosive components; sedimentation substances: < 0.1 ml/l; no particles > 100 µm; iron: < 0.2 mg/l; manganese: < 0.05 mg/l; conductivity: > 100 µS/cm; chloride: < 250 mg/l

1.2 Ozone Systems OZONFILT and DULCOZON

Identity Code Ordering System for OZONFILT OZVb systems

OZVb	Type	Ozone output
	01	10 g/h
	02	20 g/h
	03	35 g/h
	04	70 g/h
		Operating gas
	A	Air
		Version
	P	ProMinent with yellow/red master switch
	G	ProMinent with grey maintenance switch
		Cooling
	0	None
	1	Air conditioning of control cabinet
	2	Control of cooling water heat exchanger
	3	Air conditioning of control cabinet and control of cooling water heat exchanger
		Mechanical design
	0	Standard control cabinet with packaging for transport by truck
	1	Standard control cabinet with packaging for sea/air freight
	2	Stainless steel control cabinet with packaging for transport by truck
	3	Stainless steel control cabinet with packaging for sea/air freight
	4	Standard control cabinet without packaging
	5	Stainless steel cabinet without packaging
		Gas treatment
	1	Gas treatment integrated without filter package
	2	Gas treatment integrated with filter package
		Preset language
	DE	German
	EN	English
	FR	French
	IT	Italian
	ES	Spanish
		Communication interfaces
	0	None
	2	Modbus TCP
	4	PROFIBUS® DP for Siemens and Schneider controllers
	5	PROFINET®
		Additional options
	0	None
	1	Dew point sensor
	2	External water trap
	3	Ball-check Valve
	4	Dewpoint sensor + external water trap
	5	Dewpoint sensor + back pressure valve
	6	External water trap + back pressure valve
	7	Dewpoint sensor + external water trap + back pressure valve
		Mixing unit for wall-mounted cabinet systems (OZVb 1-3)
	0	None
	1	With PVC static mixer, DN 32, 0.5 – 2.8 m³/h
	2	With PVC static mixer, DN 32, 2.8 – 5 m³/h
	3	With PVC static mixer, DN 40, 5 – 10 m³/h
	4	With PVC static mixer, DN 50, 10 – 15 m³/h
	5	With PVC static mixer, DN 65, 15 – 25 m³/h





1.2 Ozone Systems OZONFILT and DULCOZON

1.2.5 System Solution OZONFILT Compact OMVb

The perfect system solution for the beverage industry

Ozone capacity 20 – 70 g/h



OZONFILT Compact OMVb is a complete, ready-to-use system solution for the generation and metering of ozone.



The ozone system OZONFILT Compact OMVb has a modular design mounted on a stainless steel frame.

A sufficient quantity and constant concentration of ozonised water is produced in the system's contact and outgassing tank. From there, it is fed back to where it is needed. The required ozone concentration has variable settings and is continuously controlled and held constant by a measuring and control circuit. Depending on the application, the ozonised water is pumped by system pressure or with one or more discharge pumps to where it is needed.

With the removal and replenishment of water in the storage tank, undissolved ozone is safely routed outside via a residual ozone gas destructor. No ozone will escape into the ambient air in normal operation.

Your Benefits

- Excellent process reliability through the use of a pre-assembled, complete ozone treatment stage with perfectly coordinated components.
- Fully piped and wired system on a stainless steel frame for plug-and-play connection.
- Modular construction, yet nevertheless can be customised.
- Compression-proof ozone generator built in compliance with DIN 19627.
- Destruction of residual ozone gas for the removal of traces of ozone gas.
- Room air monitoring for traces of ozone gas via a gas detector with a sensor with long-term stability.
- Measured value-dependent ozone metering ensures a constant ozone concentration in the contact tank.
- A central electric control ensures measured value-dependent ozone metering and the control of all connected peripheral components.
- Clear and simple operation, as well as signal exchange with higher-order control systems.

Technical Details

- **Components:**
 - Central control unit
 - Ozone generation
 - Contact and outgassing tank
 - Discharge system
 - Ozone mixing unit
 - Residual ozone gas destruction
 - Room air monitoring
- **Available options:**
 - 1 or 2 discharge pumps for pumping ozonised water to where it is used
 - Cooling water chiller for the supply of cooling water to the ozone system
 - Air conditioning unit for air conditioning of the ozone system and central control cabinet
 - Tank cleaning with built-in spray nozzle including valve combination

Field of Application

- Food and beverage industry: Disinfection of table and rinsing water

1.2 Ozone Systems OZONFILT and DULCOZON

(For more information on the ozone system OZONFILT OZVb, see page → 34)

Ozone generation, constructed in accordance with DIN 19627

This module comprises an ozone metering point and a downstream mixing section made of stainless steel with a series of static mixing elements for intensive mixing of the ozone/air mix with the water to be treated. The lines carrying the ozone and the pipework from the raw water connection to the inlet to the contact tank are made throughout in stainless steel and have been factory-pressure tested. An injector for drawing out the ozone by suction is not needed with back pressures of up to 4 bar because the ozone is generated at positive pressure.

Contact and outgassing tank

The stainless steel tank incorporates all the necessary fittings for water distribution and ensures adequate contact time and efficient outgassing.

Discharge system

As soon as the ozone concentration setpoint has been reached, the ozonised water is pumped on-demand to where it is needed. This is done by the feed pump or a discharge system with one or more discharge pumps.

Residual ozone gas destruction

A catalytic residual ozone gas destruction unit with integral water separator is used for the safe removal of undissolved ozone gas in the exhaust air from the contact tank.

Gas detector

The room air is monitored for ozone gas leaks using a gas detector with electrochemical sensor. If the alarm threshold is exceeded, ozone generation is stopped and an alarm signalled. A buzzer is activated at the same time.



1.2 Ozone Systems OZONFILT and DULCOZON

Technical Data

Type TWA for filler

		OMVb TWA 20 – 1000	OMVb TWA 35 – 1000	OMVb TWA 70 – 2000
Type ozone generator		OZVb 2	OZVb 3	OZVb 4
Reaction tank volume	l	1,000	1,000	2,000
Ozone output at 20 g/Nm ³	g/h	20	35	70
Nominal flow rate	m ³ /h	5...15	15...30	45...60
Enclosure rating		IP54	IP54	IP54

Type RI for rinser applications

		OMVb RI 20 – 500
Type ozone generator		OZVb 2
Reaction tank volume	l	500
Ozone output at 20 g/Nm ³	g/h	20
Nominal flow rate	m ³ /h	5...15
Enclosure rating		IP54

1.2 Ozone Systems OZONFILT and DULCOZON

1.2.6 Ozone System OZONFILT OZMa

Powerful and yet environmentally friendly. Disinfect and oxidise ecologically and economically.

Ozone capacity 70 – 420 g ozone/h



OZONFILT OZMa is synonymous with maximum operational safety and minimal operating costs. The ozone generator is maintenance-free and generates up to 420 g/h of ozone from compressed air.

The ozone systems OZONFILT OZMa are pressurised systems, in which the feed gas – air – is fed into the ozone generator under pressure.

Air is used as the feed gas in the ozone system OZONFILT OZMa type 1 to 6

The ozone is generated from the oxygen in the ambient air and simultaneously metered. A demand-driven, self-optimising pressure swing dryer reduces the consumption of compressed air to a minimum. Ozone can therefore be generated safely and reliably even with a high level of ambient air humidity with ozone concentrations of up to 20 g/Nm³. Using the suitable mixing equipment, ozone concentrations of between 3 and 12 ppm can be achieved in the water to be treated, depending on the temperature.

Legal notice for operating ozone systems in Europe:

For legally compliant operation of ozone systems in Europe, the system must be approved and/or registered in accordance with the Biocidal Products Regulation (EU) No. 528/2012 or REACH Regulation (EC) No. 1907/2006. As a member of EurO₃zon, ProMinent automatically provides the necessary approval for biocidal applications in accordance with the Biocidal Products Regulation on behalf of its customers. Other applications will have to be registered in accordance with REACH. This must be done by the operator but assistance can be provided by EurO₃zon. For more information, see <https://www.prominent.de/resources/Other/German/26231/20210216-Kunden-Info-BPR-REACH.pdf>.



Your Benefits

- Economical: maintenance-free generator concept with virtually unlimited service life
- Up to 30% energy savings for air treatment, thanks to demand-controlled and self-optimising air drying compared to conventional air treatment.
- Automatic control of the feed gas depends on the ozone output, therefore reduced consumption of feed gas is produced with intensive use of energy.
- High ozone concentration ensures optimum ozone solubility in water
- Direct injection without injector system for up to 2 bar back pressure
- Automatic ozone generation, virtually independent of fluctuations in mains voltage and pressure
- Simple, safe and reliable operation as well as process visualisation thanks to a large, colour and clearly arranged 6.5" touch panel
- Continuous adjustment and precise output control of between 3% and 100% of the nominal power with ozone volume displayed in 'grammes/hour'

Technical Details

- Compact mounting, ready-to-use in a painted steel cabinet or optionally in a stainless steel cabinet
- With integrated filter package for the removal of dust and small amounts of residual oil in the compressed air
- Special dielectric with excellent cooling: in spite of the low cooling water consumption, heat is quickly and efficiently discharged before the ozone produced can decompose due to excessive heat.
- PLC with integrated ozone measurement and PID control
- 7" touch panel with data logger and screen plotter
- Multiple communications interfaces (e.g. LAN, Profibus® DP, ISDN, TCP)
- Excellent efficiency: over 90% of the ozone is dissolved in the water thanks to the special construction of the mixing unit.
- Integration of a dew point sensor to monitor the quality of compressed air
- Integration of an air conditioning unit to adjust the temperature of the ozone system
- Pause input for external switching on/off
- Contact input for locking the system, for example in the absence of flow
- Digital input for connecting a gas detector
- Digital input for controlling two power stages
- 0/4-20 mA input for external output control depending on the flow or measured value with a PIC controller
- Second freely configurable 0/ 4-20 mA input
- Contact output for operating status
- Contact output for common alarm message
- Contact output for limit violation, ozone concentration in the water too low
- One freely configurable 0/ 4-20 mA output



1.2 Ozone Systems OZONFILT and DULCOZON

Field of Application

- **Potable water supply:** Oxidation of iron, manganese and arsenic, refinement and taste enhancement and disinfection
- **Wastewater treatment:** Degradation/reduction of COD and microcontaminants, reduction of sewage sludge
- **Food and beverage industry:** Oxidation of iron and manganese, disinfection of potable water and rinsing water
- **Swimming pools:** Degradation of disinfection by-products, reliable microbiological barrier and production of crystal-clear water thanks to its microfloculating effect
- **Industry:** Legionella prevention and disinfection of cooling water

1.2 Ozone Systems OZONFILT and DULCOZON

Ozone Generation System OZONFILT OZMa 1-6 A (Operating Gas - Air)

Under nominal conditions, the OZMa 1-6 A range produces up to 420 g/h of ozone from compressed air at a concentration of 20 g/Nm³. Using the designated mixing devices, ozone concentrations of between 3 and 12 ppm can be achieved in the water to be treated, depending on the temperature (theoretical value at 30 or 0 °C).

Different feature options can be achieved by combining different identity code characteristics.

The plants are pre-mounted ready for connection in a painted steel cabinet (optional stainless steel control cabinet) and need only be connected to a single-phase voltage supply, compressed air, cooling water/waste-water and ozone metering point on the customer's site.

An adequate compressed air supply and a mixing device designed for the operating conditions should be integrated for operation of the ozone plant.

Ordering information for OZONFILT OZMa systems, see page → 48, static helical mixer made of PVC or stainless steel, see page → 52.

Mixing equipment

All OZMa systems are delivered, in principle, without a mixing unit and a suitable mixing system has to be ordered separately. When selecting a suitable mixing system, please note that the mixing of ozone is more efficient the higher the water flow in the mixing system. Accordingly design the mixing system so that the flow of the water to be treated is at the upper range of the flow specification.

Static helical mixer made of PVC or stainless steel, see page → 52

Notes on installation

Keep the length of pipes for transporting ozone and the number of joints to a minimum. Monitor all adjoining rooms with a gas detector in line with the applicable German accident prevention regulations. All OZONFILT systems are equipped for fitting a gas detector, such as GMA22, ozone gas type.

Gas detector GMA22, ozone gas type, see page → 52

Ozonisation adds a large amount of gas to the water of which only a small percentage can dissolve. Accordingly, provide for adequate bleeding. As the gases discharged in this way have a considerable residual ozone concentration, appropriate residual ozone destructors should be installed.

It is necessary for the ozone generation system to be interlocked with the water flow to the ozone metering on all installations.

Install a non-return valve between the OZMa and the ozone point of injection to prevent the return of ozonised water into the pipe that transports the ozone.

Room air monitoring, see page → 52, residual ozone gas destructor, see page → 52



1.2 Ozone Systems OZONFILT and DULCOZON

Technical Data

Ozone Generation Systems OZONFILT OZMa 1-3 A (Process Gas - Air)

Ambient parameters

Max. 85% air humidity of the ambient air, non-condensing, non-corrosive, dust-free, max. ambient temperature: 40 °C (with integrated air conditioning system: 50 °C)

		OZMa 1A	OZMa 2A	OZMa 3A
Number of modules		1	1	1
Ozone capacity, measured in accordance with DIN with air at 20 °C, cooling water at 15 °C	g/h	70	105	140
Air consumption (only ozone generation)	Nm ³ /h	3.50	5.25	7.00
Ozone concentration in the gas phase referenced to nominal conditions	g/Nm ³	20	20	20
Specific energy requirement at nominal capacity	Wh/g	16.5	16.5	16.5
Power factor at full capacity	cos φ	0.95	0.95	0.95
Ozone connection		Rp 3/8"	Rp 3/8"	Rp 3/8"

Electrical Connection

		OZMa 1A	OZMa 2A	OZMa 3A
Mains connected load V/Hz/A	V/Hz/A	230/50;60/10	230/50;60/16	230/50;60/16
Enclosure rating		IP54	IP54	IP54
Degree of protection with integrated air conditioning unit (internal/external)		IP 54 / IP 34	IP 54 / IP 34	IP 54 / IP 34

Overall Dimensions (Without Mixer)

		OZMa 1A	OZMa 2A	OZMa 3A
Width	mm	1,114	1,114	1,114
Height	mm	1,961	1,961	1,961
Depth	mm	405	405	405

Weight

		OZMa 1A	OZMa 2A	OZMa 3A
Weight	kg	270	280	300

Ozone Mixing

		OZMa 1A	OZMa 2A	OZMa 3A
Max. raw water temperature	°C	35	35	35
Pressure at ozone output	bar	0.8...2.0	0.8...2.0	0.8...2.0

Air Supply

		OZMa 1A	OZMa 2A	OZMa 3A
Air demand	Nl/min	73	110	147

Air quality oil and dust-free, non-corrosive, constant priming pressure of 4.5 – 10 bar, max. temperature 40 ° C

1.2 Ozone Systems OZONFILT and DULCOZON

Cooling Water

		OZMa 1A	OZMa 2A	OZMa 3A
Cooling water consumption (15 °C)	l/h	90	135	180
Cooling water consumption (30 °C)	l/h	125	190	250
Cooling water inlet pressure	bar	2...5	2...5	2...5
Cooling water outlet, open discharge	mm	8 x 5	8 x 5	12 x 9
Cooling water inlet, PE pressure hose	mm	8 x 5	8 x 5	12 x 9

Cooling water quality No tendency to form lime scale, no corrosive components; sedimentation substances: < 0.1 ml/l; no particles > 100 µm; iron: < 0.2 mg/l; manganese: < 0.05 mg/l; conductivity: > 100 µS/cm; chloride: < 250 mg/l

Ozone Generation Systems OZONFILT OZMa 4-6 A (Process Gas - Air)

Ambient parameters

Max. 85% air humidity of the ambient air, non-condensing, non-corrosive, dust-free, max. ambient temperature: 40 °C (with integrated air conditioning system: 50 °C)

		OZMa 4A	OZMa 5A	OZMa 6A
Number of modules		2	2	3
Ozone capacity, measured in accordance with DIN with air at 20 °C, cooling water at 15 °C	g/h	210	280	420
Air consumption (only ozone generation)	Nm ³ /h	10.50	14.00	21.00
Ozone concentration in the gas phase referenced to nominal conditions*	g/Nm ³	20	20	20
Specific energy requirement at nominal capacity	Wh/g	16.5	16.5	16.5
Power factor at full capacity	cos φ	0.95	0.95	0.95
Ozone connection		Rp 3/8"	Rp 3/8"	Rp 3/8"

* Nm³ = m³ under normal [standard] conditions (p = 1.013 x 10⁵ Pa, T = 273 K)

Electrical Connection

		OZMa 4A	OZMa 5A	OZMa 6A
Mains connected load V/Hz/A	V/Hz/A	400/50;60/16	400/50;60/16	400/50;60/16
Enclosure rating		IP54	IP54	IP54
Degree of protection with integrated air conditioning unit (internal/external)		IP 54 / IP 34	IP 54 / IP 34	IP 54 / IP 34

Overall Dimensions (Without Mixer)

		OZMa 4A	OZMa 5A	OZMa 6A
Width	mm	1,320	1,320	1,606
Height	mm	1,961	1,961	1,961
Depth	mm	605	605	605

Weight

		OZMa 4A	OZMa 5A	OZMa 6A
Weight	kg	420	445	580

Ozone Mixing

		OZMa 4A	OZMa 5A	OZMa 6A
Max. raw water temperature	°C	35	35	35
Pressure at ozone output	bar	0.8...2.0	0.8...2.0	0.8...2.0



1.2 Ozone Systems OZONFILT and DULCOZON

Air Supply

		OZMa 4A	OZMa 5A	OZMa 6A
Air demand	NI/min	220	293	440

Air quality oil and dust-free, non-corrosive, constant priming pressure of 4.5 – 10 bar, max. temperature 40 ° C

Cooling Water

		OZMa 4A	OZMa 5A	OZMa 6A
Cooling water consumption (15 °C)	l/h	270	360	540
Cooling water consumption (30 °C)	l/h	300	400	600
Cooling water inlet pressure	bar	2...5	2...5	2...5
Cooling water outlet, open discharge	mm	12 x 9	12 x 9	12 x 9
Cooling water inlet, PE pressure hose	mm	12 x 9	12 x 9	12 x 9

Cooling water quality No tendency to form lime scale, no corrosive components; sedimentation substances: < 0.1 ml/l; no particles > 100 µm; iron: < 0.2 mg/l; manganese: < 0.05 mg/l; conductivity: > 100 µS/cm; chloride: < 250 mg/l

1.2 Ozone Systems OZONFILT and DULCOZON

Order information for OZONFILT OZMa Systems

OZMa	Type	Air operation
	01	70 g/h
	02	105 g/h
	03	140 g/h
	04	210 g/h
	05	280 g/h
	06	420 g/h
		Operating gas
	A	Operating gas - air
		Version
	P	ProMinent
	S	Special version
	C	ProMinent with air-conditioning
		Mechanical design
	0	Standard (packaging for transport by HGV)
	1	Standard (packaging for sea/air freight)
	2	In stainless steel cabinet (packaging for transport by HGV)
	3	In stainless steel cabinet (packaging for sea/air freight)
	M	Modified
		Operating voltage
	A	Single-phase 230 V ±10%, 50/60 Hz , only types 01 – 03
	S	Three-phase 230/400 V ±10%, 50/60 Hz , only types 04 – 06
		Gas treatment
	1	Gas treatment integrated without filter package (design operating gas - air)
	2	Gas treatment integrated with filter package (design operating gas - air)
	4	Gas treatment integrated without filter package (air operating gas version), including gas control valve
	5	Gas treatment integrated with filter package (air operating gas version), including gas control valve
		Preset language
	DE	German
	EN	English
	FR	French
	IT	Italian
	ES	Spanish
		Control
	0	Basic version with digital input to control two power stages
	1	External power control via 0/4-20 mA input, data logger
	2	External power control, ozone measurement and visualisation via screen recorder, 2 freely configurable 0/4-20 mA inputs, 1 freely configurable 0/4-20 mA output
	3	As 2 with additionally integrated PID controller for control of the ozone concentration independent of measured value and flow
		Communication interfaces
	0	None
	2	Modbus TCP
	4	PROFIBUS® DP interface
		Additional options
	0	None
	1	Dew point sensor
		Approvals
	01	CE mark
		Hardware
	0	Standard
		Software
	0	Standard

Explanation of the identity code:

- Mechanical design: With designs 0 and 1, the system is installed in a standard powder-coated steel control cabinet.
- Gas treatment: Without filter package for oil-free generated or de-oiled compressed air.
With filter package for compressed air with residual oil content.





1.2 Ozone Systems OZONFILT and DULCOZON

1.2.7 Ozone System DULCOZON OZLa

High-output ozone generator with a very compact design.

Ozone capacity 380 - 6,080 g ozone/h



DULCOZON OZLa is an ozone generator with low life cycle costs. It combines a high ozone concentration with unbeatable efficiency.



The ozone systems DULCOZON OZLa are low-maintenance generators. The systems have a modular design and can therefore be flexibly adapted to the process requirements. The simple way in which individual modules are activated and deactivated ensures efficient, built-in redundancy and increases system availability. The ozone generators can be easily integrated into a process control system.

Your Benefits

- Minimum consumption of energy through unique efficiency
- Maximum space saving of up to 70 % compared with conventional systems
- High operating safety through use of modules that can be redundantly activated and deactivated
- Minimum demand for oxygen due to high concentration of up to 15% wt
- Reliable and robust thanks to low load of electrical components
- Simple operation and process visualisation thanks to large and colour 10" touch screen panel
- Wide range of communication interfaces for connection to higher-level controls or for remote monitoring (PROFIBUS® DP, PROFINET®, Modbus TCP or RTU)

Technical Details

- 8 different sizes depending on the capacity range
- Compact construction type, ready-to-use in a painted steel cabinet
- Systems with modular design and up to 16 blocks of generators
- Specific energy consumption of less than 8.0 Wh/g of ozone at an ozone concentration of 10 % weight and cooling water use of 0.7 l/g of ozone (15 °C)
- Innovative water cooling using special cooling concept with excellent cooling properties. Rapid and efficient dissipation of heat even with little cooling water consumption to prevent the ozone generated from decomposing as a result of excessive heat
- Cooling water system per module with automatic shut-off valve, adjustment valve and monitoring device via flow and temperature sensor
- Oxygen input including pressure control system, automatic shut-off valve, adjustment valve and pressure sensor
- Safety valve to protect against overpressure
- Ozone gas outlet with back pressure valve
- PLC control with operating data recorded on an SD card
- Simple, safe and reliable operation with process visualisation thanks to colour and clear 10" touch panel
- Contact inputs for external On/Off switching, gas detector connector, external fault alert and flow control
- 4-20 mA analogue input for power control depending on the measured value combined with external measuring and control technology
- Contact outputs for common alarm message, warning and operation
- Wide range of communication interfaces for connection to higher-level controls or for remote monitoring (LAN, PROFIBUS® DP, PROFINET®, Modbus TCP or RTU)
- Evaluation and analysis program for simply and rapidly visualising operating data on a PC
- **Optional:**
 - Mass flow meter with control valve for automatic adjustment of ozone concentration at gas outlet
 - Air conditioning: The system can be equipped with integrated air conditioning at ambient temperatures above 30 °C
 - Integration of an oxygen or dew point sensor to monitor the quality of the oxygen
 - Integration of an ozone sensor to measure and monitor the ozone concentration at the ozone system's output

Field of Application

- **Drinking water supply:** Oxidation of iron, manganese and arsenic, refinement and taste enhancement and disinfection
- **Wastewater treatment:** Degradation / reduction of COD and microcontaminants, reduction of sewage sludge and disinfection
- **Aquaculture:** Oxidation and disinfection during the treatment of water for fish farming
- **Textile industry:** Oxidation of waste water and treatment of textile fibres
- **Industry:** Cooling water disinfection and legionella prevention
- **Food and beverage industry:** Oxidation of iron and manganese

1.2 Ozone Systems OZONFILT and DULCOZON

Technical Data

DULCOZON ozone generation systems OZLa01 – 160 (feed gas - oxygen)

Ambient parameters

85 % max. air humidity of the ambient air, non-condensing, non-corrosive, dust-free, max. ambient temperature: 30 °C

	OZLa010	OZLa020	OZLa030	OZLa040	OZLa060	OZLa080	OZLa120	OZLa160
Number of modules	1	2	3	4	6	8	12	16
Nominal ozone capacity at 148 g/Nm ³ (10% weight)	380	760	1,140	1,520	2,280	3,040	4,560	6,080
Ozone connection	G1/2" female thread	G1/2" female thread	G1/2" female thread	G1/2" female thread	G1/2" female thread	G1/2" female thread	G1/2" female thread	G1/2" female thread

Electrical Connection

	OZLa010	OZLa020	OZLa030	OZLa040	OZLa060	OZLa080	OZLa120	OZLa160
Mains connected load	V/Hz/A 400-3ph/50; 60/ 20	400-3ph/50; 60/ 25	400-3ph/50; 60/ 30	400-3ph/50; 60/ 50	400-3ph/50; 60/ 50	400-3ph/50; 60/ 60	400-3ph/50; 60/ 90	400-3ph/50; 60/ 120
Enclosure rating	IP54	IP54	IP54	IP54	IP54	IP54	IP54	IP54

Overall dimensions without air conditioning

	OZLa010	OZLa020	OZLa030	OZLa040	OZLa060	OZLa080	OZLa120	OZLa160
Width	mm 1,000	1,000	1,200	1,200	1,600	1,600	3,000	3,000
Height	mm 1,400	1,400	1,900	1,900	1,900	1,900	1,900	1,900
Depth	mm 400	400	600	600	600	600	600	600

Weight

	OZLa010	OZLa020	OZLa030	OZLa040	OZLa060	OZLa080	OZLa120	OZLa160
Weight	kg 171	210	295	410	540	770	1,060	1,340

Ozone Mixing

	OZLa010	OZLa020	OZLa030	OZLa040	OZLa060	OZLa080	OZLa120	OZLa160
Max. raw water temperature	°C 30	30	30	30	30	30	30	30
Pressure at ozone output	bar 0.8...2.5	0.8...2.5	0.8...2.5	0.8...2.5	0.8...2.5	0.8...2.5	0.8...2.5	0.8...2.5

Specification of Operating Gas: Oxygen

	OZLa010	OZLa020	OZLa030	OZLa040	OZLa060	OZLa080	OZLa120	OZLa160
Gas volume at nominal power 148 g/Nm ³	Nm ³ /h 2.66	5.32	7.98	10.64	15.96	21.28	31.92	42.56

Oxygen quality

Requirements of ISO 8573-1, class 1, particle content 1...5 µm max. 10 mg/m³, max. dewpoint -50 °C and max. hydrocarbons 0.01 mg/m³. Min. concentration 90 vol %, pressure 4.5...10 bar, max. temperature 30 °C



1.2 Ozone Systems OZONFILT and DULCOZON

Cooling Water

		OZLa010	OZLa020	OZLa030	OZLa040	OZLa060	OZLa080	OZLa120	OZLa160
Cooling water consumption (15 °C)	l/h	250	500	750	1,000	1,500	2,000	3,000	4,000
Cooling water inlet pressure	bar	2...2.5	2...2.5	2...2.5	2...2.5	2...2.5	2...2.5	2...2.5	2...2.5
PVC cooling water input	DN	15	15	20	20	25	25	40	40
PVC cooling water output	DN	15	15	20	20	25	25	2 x 25	2 x 25

Cooling water quality

No tendency to form lime scale, no corrosive components; sedimentation substances: < 0.1 ml/l; no solids > 100 µm; iron: < 0.2 mg/l; manganese: < 0.05 mg/l; conductivity: > 100 µS/cm; chloride: < 250 mg/l

1.2 Ozone Systems OZONFILT and DULCOZON

1.2.8 Accessories and Spare Parts for Ozone Systems

Compressors for OZONFILT OZVb 1 – 4

Atlas Copco LFX compressors

This compressor product range stands out on account of its value for money and is equipped with active start-up unloading and automatic condensation drainage by solenoid valve. The compressors are not suitable for continuous operation and stand out on account of their expected service life of up to 5,000 hours. The efficient use of the compressor can only be guaranteed if the operating duration of the OZVb system can be set as low as possible.

Type		LFX 0.7	LFX 1.5
Free air delivery rate at 7 bar	l/min	61	124
Power consumption at 7 bar	W	530	970
Air receiver capacity	l	20	20
Sound pressure level	dB(A)	62	64
Number of cylinders		1	1
Weight	kg	44	48
suitable for OZVb type		1 + 2	3 + 4

Type	Version	Order no.
LFX 0.7	230 V/50 Hz	1004458
LFX 0.7	230 V/60 Hz	1010719
LFX 1.5	230 V/50 Hz	1006343
LFX 1.5	230 V/60 Hz	1009638

Air filter kit

	Order no.
Air filter kit for Atlas Copco LFX compressors	1005789

Compressors Dürr piston compressor

The outstanding feature of this continuously rated range of compressors is their extremely robust construction, making them ideally suitable for industrial use. They are equipped with active start unloading, automatic condensate discharge by solenoid valve and an operating hours meter. PTFE-coated special aluminium pistons deliver a long service life and reliability of these compressor units.

Type		TA-080	HA-200 AK
Free air delivery rate at 7 bar	l/min	62	120
Supply max.	V AC	230	230
Mains frequency	Hz	50/60	50
Power consumption at 7 bar	W	800	1,370
Number of cylinders		1	2
Sound pressure level	dB(A)	68	69
Air receiver capacity	l	25	55
Weight	kg	49	62
suitable for OZVb type		1 + 2	3 + 4

	Order no.
TA-080	1025398
HA-200 AK	1105981

Spare parts for piston compressor TA-080

	Order no.
Air filter kit	1025400



1.2 Ozone Systems OZONFILT and DULCOZON

Spare parts for piston compressor HA 200 AK

	Order no.
Air filter kit; 1 no. needed per plunger	1105982
Vibration damper set	1105983
Cup seal and cylinder; 1 no. needed per plunger; replace after 8,000 hours of operation	1106034

Ozone gas distributor module

The ozone gas distribution module regulates the amount of ozone as is driven by demand for up to 6 points of injection. The ozone is automatically controlled to a constant setpoint or variably using an analogue signal. The measured value may be dependent on measurement of ozone concentration, ORP or flow. The desired metering quantity per point of injection is entered via a touch panel and is exactly and clearly shown on the display. Dissonant values are recognised by the intelligent control when entered.



Your Benefits

- Low investment costs thanks to gas distribution to up to 6 points of injection with one ozone generator
- Wide ozone quantity control range for each point of injection of 5-45 l/min or 10-90 l/min (air systems: 6 - 54 g/h or 12 -108 g/h; oxygen systems 45 – 405 g/h or 90 – 810 g/h)
- Simple operation and visualisation with a touch panel
- Automatic control of ozone quantities by means of a constant setpoint or depending on measured value
- Simple pneumatic and electric connection to the ozone system using matched units
- The number of points of injection can be adjusted thanks to the modular system setup
- Simple installation since all components are fitted on one panel

Technical Details

- Device with modular design and ozone gas distribution to up to 6 individual points of injection
- Panel-mounted distributor with remote control cabinet
- Simple, safe and reliable operation with process visualisation thanks to colour and clear 4.3" touch panel
- Individual panel-mounted dosing lines, fitted with the following main components
 - Manual shut-off valve to insulate the dosing line during maintenance
 - Combined gas/flow quantity measurement with control valve
 - Pneumatic diaphragm valve for automatically shutting off the dosing line in stand-by mode
- PLC control with operating data recorded on an SD card
- Contact inputs for external On/Off switching and external fault alert
- Analogue input 4-20 mA for controlling ozone quantities depending on the measured value combined with external measuring and control technology
- Contact outputs for common alarm message, warning and operation

Field of Application

- All applications needing several points of injection in their vicinity and in which the ozone gas is distributed from one ozone system to several points of injection

1.2 Ozone Systems OZONFILT and DULCOZON

Electrical Connection

Mains connected load
V/Hz/A

Enclosure rating

230-1ph/ 50;60 V/Hz/A

IP 55

Control range for feed chemical

	l/min [g/h at 20 g/Nm ³]	l/min [g/h at 150 g/Nm ³]
Size 1 control valve	5 – 45 l/min [6 – 54 g/h]	5 – 45 l/min [45 – 405 g/h]
Size 2 control valve	10 – 90 l/min [12 – 108 g/h]	5 – 90 l/min [90 – 810 g/h]

Overall dimensions and weight

	Width mm	Height mm	Depth mm	Weight kg
Distributor plate	1,300	500	220	55
Control cabinet	380	600	210	25

PVC or Stainless Steel Static Helical Mixer

Designed for intensive mixing of gas with liquid flows. 4 helical blades ensure optimum mixing of the ozone with minimal pressure loss (0.1 bar per blade at maximum flow rate). The specified flow range of the static helical mixer should be observed to achieve optimum mixing results.

Version with loose flanges to DIN 2501 and integrated injection point made of stainless steel with threaded connector for 12 mm diam. stainless steel tube or 12/9 mm PTFE hose using stainless steel support inserts. The injection point should also be fitted with a non-return valve to protect the ozone system from back-flowing water. The mixers are supplied grease-free. The stainless steel version has a G 1/4" manometer connection at the mixing point of the ozone.

Flow m ³ /h	Material	Length mm	Connection size	Order no.
0.5...2.8	PVC-U	718	DN 25	1094327
5...10	PVC-U	718	DN 40	1024324
10...15	PVC-U	718	DN 50	1024325
15...25	PVC-U	718	DN 65	1024326
25...35	PVC-U	1,100	DN 80	1024327
35...50	PVC-U	1,100	DN 100	1024328
50...90	PVC-U	1,300	DN 125	1034641
95...160	PVC-U	1,700	DN 150	1034640
5...10	1.4404	718	DN 40	1022503
10...15	1.4404	718	DN 50	1022514
15...25	1.4404	718	DN 65	1022515
25...35	1.4404	1,100	DN 80	1022516
35...50	1.4404	1,100	DN 100	1024154
50...90	1.4404	1,100	DN 125	1096162

Other sizes on request

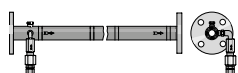

1.2 Ozone Systems OZONFILT and DULCOZON

Connecting parts for the gas pipeline

	Order no.
PTFE hose 12/9 mm, grease-less, sold in metres	37428
Stainless steel pipe 12/10 mm, sold in metres	15743
Stainless steel pipe 12/10 mm, grease-less, 1.4 m	1022463
Stainless steel support inserts, 2 No. for 12/9 mm PTFE hose, grease-less	1025397
Stainless steel coupling 12 mm - R 1/4, grease-less	1025755
Stainless steel fitting 12 mm - R 3/8, grease-less	1034642
3/8" double nipple	1005825
Stainless steel 90° elbow D 12 - D 12, grease-less	1022462
Stainless steel back pressure valve for OZMa 1 – 3 A and OZVb, adjustable pressure range 0.5 – 10 bar, connector G 3/4" male thread, grease-free	1039408
Spare parts kit for back pressure valve order no. 1039408	1039410
Stainless steel back pressure valve for OZMa 4 – 6 A and OZLa, adjustable pressure range 0.5 – 10 bar, connector G 1 1/4" male thread, grease-free	1039409
Spare parts kit for back pressure valve order no. 1039409	1039411

Accessories for OZONFILT OZVb

Connector kit for installing OZVb systems for the compressed air, ozone gas and cooling water interfaces. Comprising angular plug connectors, angular threaded connectors, threaded connector and 8/5 mm hose DE FDA 35m. Fittings and pipework material for the line carrying ozone gas are not included.

	Order no.
Remote maintenance module for OZONFILT OZMa	1110473

Bleed valves

Suitable for types	Connection size	Pressure bar	Max. gas flow at $\Delta p =$ 0.1 bar Nm ³ /h	Order no.
OZVb 1 – 7	R 3/4" internal x R 1/2" external	0...6.0	3.1	302525
OZMa 1 – 30/OZMa 1A	R 1" internal x R 1/2" external	0...2.0	3.1	302526
OZMa 2-4A / OZMa 4-6O	R 1" internal x R 3/4" external	0...2.0	14.0	303845
OZMa 2-4A / OZMa 4-6O	DN65" female x R 3/4" male	0...2.0	25.0	1026373

Bleed valves made of stainless steel 1.4571 in ozone-resistant version for mounting on reaction tanks.



1.2 Ozone Systems OZONFILT and DULCOZON

Residual Ozone Gas Destructor

Residual ozone gas destruction is used to remove traces of ozone gas from the exhaust air coming from the reaction tank. As the exhaust air from the reaction chamber still contains water, provision must be made by means of appropriate pipework for a drainage line on the inlet side. As the exhaust air downstream of the residual ozone gas destructor is still 100% saturated with water vapour and small fluctuations in temperature can also result in condensation flowing back at the outlet side, a drain connection should also be provided here. The exhaust air from a filter system possibly fitted downstream can also pass through this residual ozone destruction unit.

PVC version

Active carbon granulate-based residual ozone destructor in a PVC housing.

	Type	Ozone quantity g/h	Order no.
Residual ozone destructor 3 l	10	10	879022
Residual ozone destructor 14 l	40	40	1004267
Residual ozone destructor 30 l	100	100	879019
Residual ozone destructor 60 l	200	200	879018

Note:

The stated ozone quantities refer to quantities added to the raw water. The residual ozone destructor is designed for the normal residual ozone concentration found in swimming pool applications. It should only be used in plants with air as operating gas and a maximum concentration of 1.5 g of ozone/m³ treated water.

Stainless steel version

Residual ozone destructor based on a maintenance-free MnO catalyst in a stainless steel housing (1.4571) with integrated heating 230 V, 50-60 Hz. Connections Rp 1/2" or flanges according to DIN 2642, PN10. Types 18 to 110 m³/h additionally with ball valve Rp 1/2" as a condensation drain.

Max. gas flow m ³ /h	Heating power W	Dimensions H x W x D mm	Connection size	Order no.
1.5	100	700 x 110 x 180	Rp 1/2"	1018440
8.0	100	735 x 110 x 235	Rp 1/2"	1018406
18.0	140	1,154 x 275 x 240	DN 25	1019155
28.0	140	1,154 x 300 x 259	DN 25	1021037
40.0	500	1,156 x 330 x 264	DN 25	1026335
73.0	500	1,158 x 400 x 320	DN 32	1019971
110.0	500	1,160 x 450 x 375	DN 40	1027238

Note:

The catalytic residual ozone destructor should only be used in chlorine-free gas flows. The PVC version should therefore be used with swimming pool applications.

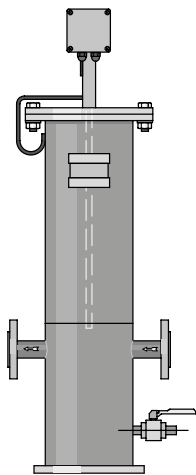



1.2 Ozone Systems OZONFILT and DULCOZON

1.2.9 Room Air Monitoring

Gas detector GMA 22 ozone

The GMA 22 ozone gas warning device is a compact measuring and control unit for monitoring ozone gas leakages in ozone installations.



Type GMA 22	Ozone
Warning at approx.	0.3 ppm/vol%
Alarm at approx.	0.5 ppm/vol%
Permissible ambient temperature	0...45 °C
Protection class housing	IP 64
Dimensions (without PGs, without sensor) H x W x D	140 x 97 x 50 mm
Supply	100 – 240 V AC / 50 – 60 Hz
DC power connection	20 - 30 V DC
Max. power consumption incl. sensor	20 W
Warm-up phase max.	150 s
'Warning' relay contact, latching	250 V ; 3 A
'Alarm' relay contact, latching	250 V ; 3 A
'Horn' relay contact, latching, can be acknowledged	250 V ; 3 A
Sensor measuring principle	electrochemical
Maximum sensor life	2 a

	Order no.
Gas detector GMA 22/1, 230V including 1 transmitter with ozone sensor and 10 m connecting cable	1117289
Gas detector GMA 22/1, 24 V DC including 1 transmitter with ozone sensor and 10 m connecting cable	1117292
Gas detector GMA 22/2, 230V including 2 transmitters with ozone sensor and 10m connecting cable	1117305
Gas detector GMA 22/2, 24 V DC including 2 transmitters with ozone sensor and 10m connecting cable	1117309
Replacement sensor for chlorine, chlorine dioxide, ozone	1117331



Note: The sensor is cross-sensitive to other oxidising gases.

1.2 Ozone Systems OZONFILT and DULCOZON



Gas detector GMA 22 Oxygen

The GMA 22 oxygen gas detector is designed as a compact measuring and switching unit for monitoring the ambient air for dangerous concentrations of oxygen.

Type GMA 22	Oxygen
Alarm 1 at approx.	19 vol% not met
Alarm 2 at approx.	17 vol% not met
Alarm 3 at approx.	23 vol% exceeded
Permissible ambient temperature	0...45 °C
Protection class housing	IP 64
Dimensions (without PGs, without sensor) H x W x D	140 x 97 x 50 mm
Supply	100 – 240 V AC / 50 – 60 Hz
DC power connection	20 - 30 V DC
Max. power consumption incl. sensor	20 W
Warm-up phase max.	150 s
'Alarm 1' relay contact, self-extinguishing	250 V ; 3 A
'Alarm 2' relay contact, latching	250 V ; 3 A
'Alarm 3' relay contact, latching	250 V ; 3 A
'Horn' relay contact, latching, can be acknowledged	250 V ; 3 A
Sensor measuring principle	electrochemical
Maximum sensor life	2 a

	Order no.
Gas detector GMA 22/1, 230 V including 1 transmitter with oxygen sensor and 10 m connecting cable	1120007
Gas detector GMA 22/1, 24 V DC including 1 transmitter with oxygen sensor and 10 m connecting cable	1120008
Gas detector GMA 22/2, 230 V including 2 transmitters with oxygen sensor and 10 m connecting cable	1120009
Gas detector GMA 22/2, 24 V DC including 2 transmitters with oxygen sensor and 10 m connecting cable	1120010
Replacement sensor for oxygen	1120037

Flash light-horn

Combined horn and red warning lamp. IP 65 housing made of impact-resistant grey polycarbonate with a transparent polycarbonate dome. Rating values: 230 V AC, 50 mA.

	Order no.
Flash light-horn, red with continuous tone	1083160

Gas tracing pump

Hand-operated test tube pump (does not run continuously) for fast and accurate measurement of ozone gas. Complete with 10 ozone gas test tubes 0.05-5 ppm in carrying case.

	Order no.
Gas tracing pump	1025533

Potassium iodide starch paper

Roll with 4.8 m test strip for leak detection on pipelines carrying ozone gas.

	Order no.
Potassium iodide starch paper	1025575

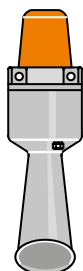

1.2 Ozone Systems OZONFILT and DULCOZON

Cooling Water Chiller

A cooling water chiller can be used as an alternative to the use of freshwater as cooling water. The cooling water is fed through the chiller and ozone system in a circuit. The cooling water chiller releases heat to the surroundings.

- Single circuit system with tank open to the atmosphere
- Air-cooled refrigeration unit
- Integrated evaporator
- Tank with water level indication and level switch with alarm contact
- Microprocessor-controlled temperature controller with digital display
- Integrated circulation pump
- Manometer
- Stainless steel housing
- Installation material with 10 m hose for direct connection to the ozone system
- Electrical contact inputs/outputs: On/Off contact, alarm contact, min. water level contact

Order no.		1075498	1075499	1075501
Refrigerant	CFC-free	R134a	R134a	R134a
Useful cooling output at 20 °C/50 Hz	kW	2.1	2.1	3.0
Operating range	°C	+10/+30	+10/+30	+10/+30
Ambient temperature	°C	10 – 55	10 – 55	10 – 55
Pump	Type	Speck, LNY-2841	Speck, LNY-2841	Speck, LNY-2841
Pump capacity at 2 bar	l/min	3.4	3.4	3.4
Water connectors	Inch	6x4	12x9	12x9
Power consumption	kW	1.9	1.9	1.9
Mains connection	V/Hz	230/50 – 60	230/50 – 60	230/50 – 60

	Type	Order no.
Cooling Water Chiller	OZVb 1 – 4	1075498
Cooling Water Chiller	OZMa 1 – 2 A	1075499
Cooling Water Chiller	OZMa 3 A	1075501

1.2 Ozone Systems OZONFILT and DULCOZON

1.2.10 Personal Protection Accessories

Gas mask

Ozone-resistant, full-face respiratory protective mask with panoramic window shield according to EN 136 Class 3. Medium size with EN 148-1 threaded connector. Complete with combination filter NO-P3 and carrying case.

	Order no.
Gas mask	1025574

Warning label

Warning label in accordance with the "Guidelines for the use of ozone for water treatment" ZH 1/474, issued by the central office of the industrial safety associations. Version supplied as a combined adhesive label with markings as follows: warning sign, ozone plant room indication and prohibited activity signs.

	Order no.
Warning label	740921

Emergency stop switch

For installation near the door of the ozone system room. IP 65 PVC housing.

	Order no.
Emergency stop switch	700560

Overvoltage Protection

Overvoltage protection for OZONFILT systems operated at 230 V 50-60 Hz.

The external overvoltage protection is intended for the operating case where the device's internal protection is insufficient for surge voltages of 1 kV between the conductors and of 2 kV to earth. To protect the system when the supply mains is prone to power transients an overvoltage trip can be fitted as a low-protection surge arrester to significantly increase the stability of the ozone systems.

Whether the low protection surge arrester requires further measures such as medium and main protection can only be determined by thorough investigation of the voltage behaviour on-site.

	Order no.
Fine protection PT 2-DE IS 230 IAC	733010

Replacement Plug-in Insert After Tripping

	Order no.
Replacement plug-in insert PT 2-DE / S 230 / AC - ST	733011



1.3 Bello Zon Chlorine Dioxide Systems

1.3.1 Chlorine Dioxide in Water Treatment

Chlorine dioxide is an exceptionally reactive gas, which is not stored due to its instability, but rather should only be manufactured in special systems to meet requirements at its place of use.

Chlorine dioxide has a number of advantages over chlorine, which is predominantly used in water disinfection. For instance, the disinfection effect does not reduce as the pH increases, as is the case with chlorine; rather it increases slightly. Chlorine dioxide remains stable in pipework systems over long periods and provides microbiological water protection for many hours and up to several days. Ammonia or ammonium, which cause considerable chlorine consumption, do not react with chlorine dioxide so that the metered chlorine dioxide remains fully available for disinfection purposes. Chlorophenols, strongly smelling compounds, which can result from the chlorination of water, are not formed with chlorine dioxide. Trihalomethanes (THMs), a substance class, which, like its main representative, chloroform, is suspected of being carcinogenic, result from the reaction of chlorine with dissolved matter naturally found in water (humic acids, fulvic acids, etc.). If chlorine dioxide is used as an alternative disinfectant these substances are not produced.

Advantages of chlorine dioxide:

- Disinfectant effect regardless of the pH value.
- Sustained-release effect thanks to long-term stability in the piping system.
- Degradation of biofilms in pipework and tanks, thus reliable protection of entire water systems against legionella attack.
- No reaction with ammonia or ammonium.
- No formation of chlorophenols and other strongly smelling compounds that may be produced during water chlorination.
- No formation of trihalomethanes (THM) and other chlorinated hydrocarbons, no increase in AOX values.

Chlorine Dioxide Applications

Municipal potable water and wastewater companies

- Disinfection of potable water
- Disinfection of wastewater

Hotels, hospitals, care homes, sports centres etc.

- Combating legionella in cold and hot water systems
- Water disinfection in the cooling towers of air conditioning systems
- Disinfection of swimming pool filters

Food and beverage industry

- Disinfection of product and process water
- Bottle cleaning, rinsers and pasteurisers
- Cold-sterile bottling
- Disinfectant in CIP systems
- Water vapour treatment (condensate) in the dairy industry
- Washing water disinfection for fruit, vegetables, seafood, fish and poultry

Market gardening

- Disinfection of irrigation water in plant cultivation

Industry

- Cooling water treatment
- Combating legionella in cooling water circuits
- Disinfection of process water
- Removal of odorous substances in air scrubbers
- Slime control in the paper industry

1.3 Bello Zon Chlorine Dioxide Systems

Bello Zon System Technology

Bello Zon chlorine dioxide generation and metering systems use the chlorite/acid process. These systems generate a chlorine-free chlorine dioxide solution through the reaction of sodium chlorite solution with hydrochloric acid.

Features

- Precise chlorine dioxide production thanks to the use of calibratable metering pumps for the starting chemicals.
- Convenient and easy operation thanks to microprocessor control with display of all relevant operating parameters and error messages in plain text.
- Display of the current production quantity as well as the flow rate of the connected flow meters with CDV and CDK.
- Highest safety level provided as standard thanks to construction and operation in accordance with DVGW specifications W 224 and W 624.

Bello Zon CDLb

Compact dimensions and maximum cost-effectiveness - for one or more points of injection.

0 – 120 g/h preparation capacity with storage of up to 60 g of chlorine dioxide for peak metering.

Max. flow at 0.2 ppm ClO₂ metering is 600 m³/h.

Bello Zon CDEb

Bello Zon CDEb impresses customers with its ultra-simple operation and very clear construction.

5 – 200 g/h chlorine dioxide. Max. flow at 0.2 ppm ClO₂ dosing is 1,000 m³/h

Bello Zon CDVd

Bello Zon CDVd impresses customers with its safe and economical handling of diluted chemicals.

15 – 12,000 g/h chlorine dioxide. Max. flow at 0.2 ppm ClO₂ metering is 60,000 m³/h

Bello Zon CDKd

Bello Zon CDKd for treating average to large volumes of water.

5 – 2000 g/h chlorine dioxide. Max. flow at 0.2 ppm ClO₂ metering is 10,000 m³/h

ProMinent provides the advice needed for the safe operation of a chlorine dioxide system

For every new project, our engineers draw on the experience that we have been adding to since 1976. We have experience in the following applications:

- Evaluation of the situation on-site by trained, expert field sales staff.
- Interpretation of water analyses.
- Project planning for the system.
- Commissioning and system maintenance by our trained service technicians.



1.3 Bello Zon Chlorine Dioxide Systems

1.3.2 Performance Overview of Chlorine Dioxide Systems

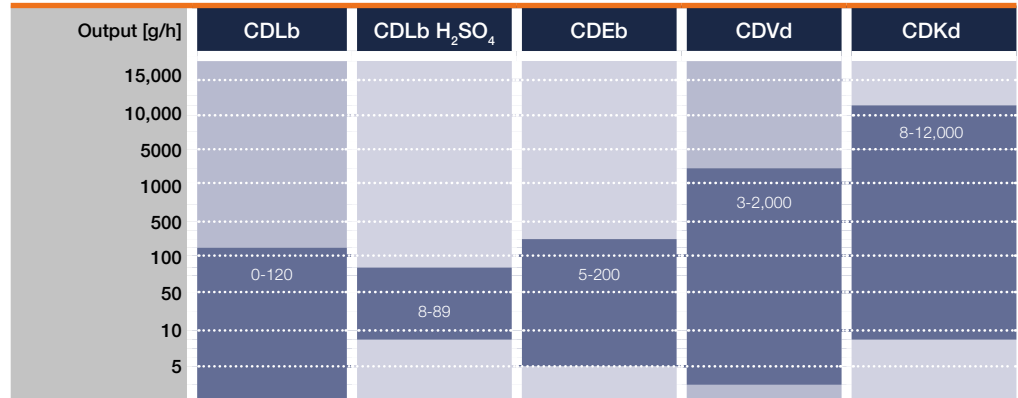

Production process

	CDLb	CDLb H ₂ SO ₄	CDEb	CDVd	CDKd
Production process	Sodium chlorite (diluted) 7.5 % NaClO ₂ + 9 % HCl	Sodium chlorite 7.5 % NaClO ₂ + 25 % H ₂ SO ₄	Sodium chlorite (diluted) 7.5 % NaClO ₂ + 9 % HCl	Sodium chlorite (diluted) 7.5 % NaClO ₂ + 9 % HCl	Sodium chlorite (concentrated) 24.5 % NaClO ₂ + 25 - 37 % HCl

Applications

Applications	CDLb	CDLb H ₂ SO ₄	CDEb	CDVd	CDKd
Combating Legionella	■				
Food and beverage industry	■	■	■	■	
Municipal drinking water and wastewater treatment	■		■	■	■
Industry (cooling tower wastewater/process water etc.)	■	■	■	■	■

1.3 Bello Zon Chlorine Dioxide Systems

1.3.3 Questionnaire on the Design of a Chlorine Dioxide System

Use of the chlorine dioxide plant:

- for disinfection of
 - Drinking water
 - Industrial water
 - Process water in the food industry
 - Wastewater
 - Cooling water
 - _____

- for oxidation of
 - Iron, manganese, nitrite, sulphide etc.
 - Swimming pool water
 - Odour
 - _____

- _____

Water values:

- | | | | |
|------------------------------|-----------------------------------|---|--|
| Max. water flow rate | m ³ /h | Maximum water pressure | _____ bar |
| Water flow rate | <input type="checkbox"/> constant | <input type="checkbox"/> fluctuating from | _____ m ³ /h to _____ m ³ /h |
| pH value | _____ | Iron (Fe ²⁺) | _____ mg/l |
| Temperature | _____ °C | Manganese (Mn ²⁺) | _____ mg/l |
| Solid fraction | _____ mg/l | Nitrite (NO ₂) | _____ mg/l |
| Alkalinity K _{S4,3} | _____ mmol/l | Sulphide (S ²⁻) | _____ mg/l |
| | | TOC (total organic carbon) | _____ mg/l |

Response time to application:

_____ m³ volume reaction tank or _____ minutes residence time in entire system.

Type of metering:

- constant
- flow-proportional
- depending on measured value

Desired amount of metering: _____ mg/l

Desired concentration after chlorine dioxide metering: _____ mg/l

Other requirements:



1.3 Bello Zon Chlorine Dioxide Systems

1.3.4

Chlorine Dioxide System Bello Zon CDLb

Compact dimensions and maximum cost-effectiveness - chlorine dioxide system for one or more points of injection.

0 – 120 g/h capacity with storage of up to 60 g of chlorine dioxide for peak metering. Max. flow rate at 0.2 ppm ClO₂ metering capacity of 600 m³/h



Chlorine dioxide system for production of a chlorine-free chlorine dioxide solution, especially suitable for multiple points of injection. Bello Zon CDLb produces ClO₂ discontinuously using the acid/chlorite process with diluted chemicals.



In batch production, a chlorine dioxide solution is generated from a sodium chlorite solution and hydrochloric acid. This is an extremely safe, managed process.

The chlorine dioxide solution produced is buffered in an integrated or external buffer tank at a concentration of 1000 or 2000 mg/l.

Because the chlorine dioxide is buffered in this buffer tank, the system can be designed in line with average rather than peak consumption. This drastically reduces investment costs in comparison with conventional systems.

The ProMinent product range includes a wide range of metering pumps and control versions from which to choose when operating several points of injection using chlorine dioxide from a buffer tank.

No chlorine dioxide can escape from the system due to the closed gas transport system, thereby guaranteeing economical, environmentally friendly operation with minimal use of chemicals. In addition, the chlorine dioxide solution generated with maximum yield offers excellent long-term stability with minimal consumption of starting chemicals.

Integration of the system into your process is simple and reliable thanks to a wide range of accessory modules. Please ask our sales representatives for information about our modular systems specifically designed for CDLb.

The chlorine dioxide system Bello Zon CDLb meets the high standards stipulated in specifications W 224 and W 624 published by the German Association for Gas and Water (DVGW).

Your Benefits

- Reduced costs thanks to minimal use of chemicals
- Cost-effective way to provide several points of injection
- Quick ramp-up time after downtime thanks to long-term stability of chlorine dioxide liquid
- Maximum output due to closed gas transport system
- Outstanding operating safety and reliability, thanks to intrinsically safe process control
- Location-independent system monitoring in real-time via the DULCONNEX Platform: Improved process reliability. Reliability and transparency due to real-time monitoring, individual alarms and automated reports.
- Ultra-simple process integration



Technical Details

- Power supply: 100-230 V, 50/60 Hz
- Inputs: 2 freely configurable digital inputs for the functions Pause, High metering, Intermittent metering or Manual metering as well as an external collective malfunction signal, 4 digital inputs for monitoring the chemical supply (warning / empty message), 1 digital input for contact water meter 0.25 - 20 Hz, 1 frequency input for water meter 10 - 10,000 Hz
- Outputs: 1 operating signal relay, 1 alarm signal relay, 1 warning signal relay, 1 voltage output +5 V as supply voltage for water meter with Hall sensor
- Operating fluids: Sodium chlorite 7.5%, purity in accordance with EN 938, hydrochloric acid 9%, purity in accordance with EN 939, potable water
- Protection class: IP 65

Field of Application

- Disinfection in the food and beverage industry. Especially for bottle rinsers, CIP (cleaning in place), bottle washing machines and fruit/vegetable washing
- Legionella control and prevention, e.g. in hotels or hospitals
- Market gardening: Germ-free irrigation water and sprinkler irrigation water
- Treatment of cooling water and potable water
- Filter disinfection, e.g. in swimming pools



1.3 Bello Zon Chlorine Dioxide Systems

Technical data

Type	Generation capacity	Operating temperature	Concentration	Minimum metering rate	Dimensions H x W x D	Weight
	g/h	°C	mg/l	l/h	mm	kg
CDLb 06	6	10...40	1,000	8	1,236 x 878 x 306	41
CDLb 12	12	10...40	2,000	8	1,236 x 878 x 306	42
CDLb 22	22	10...40	2,000	13	1,236 x 878 x 306	46
CDLb 55	55	10...40	2,000	30	1,550 x 800 x 345	73
CDLb 120	120	10...40	2,000	-	1,300 x 880 x 425	55

Interfaces

Type CDLb		6 g/h	12 g/h	22 g/h	55 g/h	120 g/h
Water inlet	ProMinent/Neutral	12-9	12-9	12-9	12-9	Di20/DN15
	Switzerland	Di20/DN15	Di20/DN15	Di20/DN15	Di20/DN15	Di20/DN15
Connector dimensions of metering pump for acid and chlorite		6x4	6x4	6x4	6x4	6x4
ClO ₂ output	with internal storage/pump/back pressure valve	6-4	6-4	12-9	12-9	
	with internal storage/pump	6-4	6-4	12-9	12-9	
	with internal storage, without pump	6-4	6-4	8-5	12-9	
	with external storage, without pump (reactor outlet)	12-9	12-9	12-9	12-9	Di25/DN20
	external storage (suction lance connector)	Di25/DN20	Di25/DN20	Di25/DN20	Di25/DN20	Di25/DN20





1.3 Bello Zon Chlorine Dioxide Systems

1.3.5 Chlorine Dioxide System Bello Zon CDLb H₂SO₄

Gentle disinfection without corrosion
8 – 89 g/h chlorine dioxide generation



Bello Zon CDLb H₂SO₄ especially for applications critical with regard to corrosion for the production of low-chloride chlorine dioxide liquid. With the chlorine dioxide system, ClO₂ is produced discontinuously following the acid/chlorite procedure.



The system produces an extremely low-chloride chlorine dioxide solution from sodium chlorite and sulphuric acid instead of hydrochloric acid. Batch production is an extremely safe, managed process. The low-chloride CDLb solution is suited to disinfection applications in sensitive stainless steel environments such as tunnel pasteurisers, autoclaves, cooling circuits, belt-based lubrication systems.

The chlorine dioxide is buffered in an integrated or external buffer tank at a concentration of 1500 mg/l.

The broad product range of metering pumps and control variants can be used to run several points of injection with chlorine dioxide from one buffer tank.

The closed gas circuit prevents chlorine dioxide from being able to escape from the system, guaranteeing economical and environmentally friendly operation with minimal use of chemicals.

Your Benefits

- Very little potential for corrosion due to the low chloride concentration
- Ideal specifically for circulation systems
- Simple way to provide several points of injection
- Outstanding operating safety and reliability thanks to intrinsically safe process control
- System monitoring in real-time from any location via DULCONNEX Platform: improved process reliability, overall reliability and transparency through real-time monitoring, individual alarms and automated reports



Technical Details

- Power supply: 100-230 V, 50/60 Hz
- Inputs: 2 freely configurable digital inputs for the Pause, High metering, Intermittent metering or Manual metering functions as well as an external common alarm, 4 digital inputs for monitoring the chemical supply (warning / empty message), 1 digital input for contact water meter 0.25 - 20 Hz, 1 frequency input for water meter 10 - 10,000 Hz
- Outputs: 1 operating signal relay, 1 alarm signal relay, 1 warning signal relay, 1 +5 V voltage output as supply voltage for water meter with Hall sensor
- Operating substances: 7.5% sodium chlorite, purity in accordance with EN 938, 25 % sulfuric acid, purity in accordance with EN 939, potable water
- Degree of protection: IP 65

Field of Application

- Tunnel pasteuriser
- Bottle cleaning
- Belt-based lubrication

1.3 Bello Zon Chlorine Dioxide Systems

Technical Data

Type	Generation capacity g/h	Operating temperature °C	Concentration mg/l	Minimum metering rate l/h	Dimensions H x W x D mm	Weight kg
CDLb 08 H ₂ SO ₄	8	10...40	1,500	8	1,236 x 878 x 306	42
CDLb 16 H ₂ SO ₄	16	10...40	1,500	13	1,236 x 878 x 306	46
CDLb 41 H ₂ SO ₄	41	10...40	1,500	30	1,550 x 800 x 345	73
CDLb 89 H ₂ SO ₄	89	10...40	1,500	-	1,300 x 880 x 425	55

Interfaces

Type CDLb H ₂ SO ₄		8 g/h	16 g/h	41 g/h	89 g/h
Water inlet	ProMinent/Neutral	12-9	12-9	12-9	Di20/DN15
	Switzerland	Di20/DN15	Di20/DN15	Di20/DN15	Di20/DN15
Connector dimensions of metering pump for acid and chlorite		6x4	6x4	6x4	6x4
ClO ₂ output	with internal storage/pump/back pressure valve	6-4	12-9	12-9	
	with internal storage/pump	6-4	12-9	12-9	
	with internal storage, without pump	6-4	12-9	12-9	
	with external storage, without pump (reactor outlet)	12-9	12-9	12-9	Di25/DN20
	external storage (suction lance connector)	Di25/DN20	Di25/DN20	Di25/DN20	Di25/DN20

1.3 Bello Zon Chlorine Dioxide Systems

Identity Code Ordering System for Chlorine Dioxide Systems Bello Zon CDLb H₂SO₄

CDLb	ClO ₂ production capacity
02	CDLb 06 = 6 g/h
04	CDLb 12 = 12 g/h
06	CDLb 22 = 22 g/h
08	CDLb 55 = 55 g/h
10	CDLb 120 = 120 g/h
24	CDLb 08 H ₂ SO ₄ = 8 g/h
26	CDLb 16 H ₂ SO ₄ = 16 g/h
28	CDLb 41 H ₂ SO ₄ = 41 g/h
30	CDLb 89 H ₂ SO ₄ = 89 g/h
Equipment	
0 *	With receiver tank and pump and back pressure valve, Not with CDLb 120
1 *	With receiver tank and pump, Not with CDLb 120
2	With receiver tank, without pump, Not with CDLb 120
3	With 30 l receiver module, without pump
Version	
P	ProMinent
S	Swiss, DN 15 water connection, rigid piping
N	Neutral
Operating voltage	
0	230 V, 50/60 Hz
1	115 V, 50/60 Hz
Suction lance, suction assembly	
0	None
1	With suction lance
2	With suction lance and collecting pan
3	With suction lance, collecting pan, angle valve and PE hose 12x9 (10 m)
Preset language	
DE	German
EN	English
FR	French
IT	Italian
ES	Spanish

* ClO₂ discharge pumps are not equipped with a fault indicating relay. This is available as an accessory.



1.3 Bello Zon Chlorine Dioxide Systems

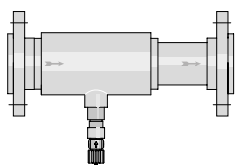

Accessories and Maintenance Sets for Chlorine Dioxide Systems Bello Zon CDLb

Point of injection

Corrosion-resistant point of injection made of PVC-U or made of PVC-C for hot water applications with integrated mixer elements and maintenance-free PVDF injection valve.

CDL points of injection with flange

	Material	Installation length mm	Order no.
CDL DN 50 point of injection	PVC-U	450	1027611
CDL DN 65 point of injection	PVC-U	400	1026490
CDL DN 80 point of injection	PVC-U	400	1027612
CDL DN 100 point of injection	PVC-U	470	1034693
CDL DN 125 point of injection	PVC-U	550	1047692
CDL DN 150 point of injection	PVC-U	680	1047693
CDL DN 50 point of injection	PVC-C	450	1080375
CDL DN 65 point of injection	PVC-C	400	1029326
CDL DN 80 point of injection	PVC-C	400	1029327

CDL points of injection with threaded connector (including separate reductions in each case to one nominal width smaller)

	Material	Order no.
CDL DN 25 point of injection	PVC-C	1080362
CDL DN 40 point of injection	PVC-C	1080374
CDL DN 25 point of injection	PVC-U	1080359
CDL DN 40 point of injection	PVC-U	1080361

Temperature/pressure resistance of point of injection CDL

Water temperature (°C)	Maximum permissible operating pressure (bar)	
	PVC-U	PVC-C
40	12	12
50	7	9,5
60	4,5	7,5
70	–	5
80	–	3

Back pressure valve and angle valve

Back pressure valve type DHV with wall bracket and 6 x 4 mm hose connection for fitting in the chlorine dioxide dosing line. Angle valve for the transition from the customer's process water pipeline to the 12x9 hose connector on the CDLb.

	Order no.
DHV-S-DK 1.0 - 10 bar d6-12 PC1	302321
Angle valve kit (support insert 12/9 stainless steel) DN15 G 1/2" brass	1046350

Fault indicating relay for the ClO₂ pump

Fault indicating relay retrofit kit for the ClO₂ discharge pump

	Order no.
Fault indicating relay, 3-pin	1029309

Safety collecting pan for chemical tanks (CDLb)

Collecting pan for a 25 l Bello Zon acid or Bello Zon chlorite chemical canister.

Dimensions (HxWxD): 266 x 400 x 500 mm

	Order no.
Safety collecting pan CDLb	791726

1.3 Bello Zon Chlorine Dioxide Systems

Maintenance kits for Bello Zon CDLb

For CDLb with storage tank, pump and back pressure valve

	Type	Order no.
Annual maintenance kit, 230 V	CDLb 06, CDLb 12, CDLb 08 H ₂ SO ₄	1044484
Annual maintenance kit, 230 V	CDLb 22, CDLb 16 H ₂ SO ₄	1044501
Annual maintenance kit, 230 V	CDLb 55, CDLb 41 H ₂ SO ₄	1044509
Annual maintenance kit, 115 V	CDLb 06, CDLb 12, CDLb 08 H ₂ SO ₄	1079198
Annual maintenance kit, 115 V	CDLb 22, CDLb 16 H ₂ SO ₄	1079202
Annual maintenance kit, 115 V	CDLb 55, CDLb 41 H ₂ SO ₄	1079206
3-yearly maintenance set, 230 V	CDLb 06, CDLb 12, CDLb 08 H ₂ SO ₄	1044494
3-yearly maintenance set, 230 V	CDLb 22, CDLb 16 H ₂ SO ₄	1044502
3-yearly maintenance set, 230 V	CDLb 55, CDLb 41 H ₂ SO ₄	1044510
3-yearly maintenance set, 115 V	CDLb 06, CDLb 12, CDLb 08 H ₂ SO ₄	1045212
3-yearly maintenance set, 115 V	CDLb 22, CDLb 16 H ₂ SO ₄	1045216
3-yearly maintenance set, 115 V	CDLb 55, CDLb 41 H ₂ SO ₄	1045220

For CDLb with receiver tank and pump

	Type	Order no.
Annual maintenance kit, 230 V	CDLb 06, CDLb 12, CDLb 08 H ₂ SO ₄	1044495
Annual maintenance kit, 230 V	CDLb 22, CDLb 16 H ₂ SO ₄	1044503
Annual maintenance kit, 230 V	CDLb 55, CDLb 41 H ₂ SO ₄	1044511
Annual maintenance kit, 115 V	CDLb 06, CDLb 12, CDLb 08 H ₂ SO ₄	1079199
Annual maintenance kit, 115 V	CDLb 22, CDLb 16 H ₂ SO ₄	1079203
Annual maintenance kit, 115 V	CDLb 55, CDLb 41 H ₂ SO ₄	1079207
3-yearly maintenance set, 230 V	CDLb 06, CDLb 12, CDLb 08 H ₂ SO ₄	1044496
3-yearly maintenance set, 230 V	CDLb 22, CDLb 16 H ₂ SO ₄	1044504
3-yearly maintenance set, 230 V	CDLb 55, CDLb 41 H ₂ SO ₄	1044512
3-yearly maintenance set, 115 V	CDLb 06, CDLb 12, CDLb 08 H ₂ SO ₄	1045213
3-yearly maintenance set, 115 V	CDLb 22, CDLb 16 H ₂ SO ₄	1045217
3-yearly maintenance set, 115 V	CDLb 55, CDLb 41 H ₂ SO ₄	1045221

For CDLb with receiver tank without pump

	Type	Order no.
Annual maintenance kit, 230 V	CDLb 06, CDLb 12, CDLb 08 H ₂ SO ₄	1044497
Annual maintenance kit, 230 V	CDLb 22, CDLb 16 H ₂ SO ₄	1044505
Annual maintenance kit, 230 V	CDLb 55, CDLb 41 H ₂ SO ₄	1044513
Annual maintenance kit, 115 V	CDLb 06, CDLb 12, CDLb 08 H ₂ SO ₄	1079200
Annual maintenance kit, 115 V	CDLb 22, CDLb 16 H ₂ SO ₄	1079204
Annual maintenance kit, 115 V	CDLb 55, CDLb 41 H ₂ SO ₄	1079208
3-yearly maintenance set, 230 V	CDLb 06, CDLb 12, CDLb 08 H ₂ SO ₄	1044498
3-yearly maintenance set, 230 V	CDLb 22, CDLb 16 H ₂ SO ₄	1044506
3-yearly maintenance set, 230 V	CDLb 55, CDLb 41 H ₂ SO ₄	1044514
3-yearly maintenance set, 115 V	CDLb 06, CDLb 12, CDLb 08 H ₂ SO ₄	1045214
3-yearly maintenance set, 115 V	CDLb 22, CDLb 16 H ₂ SO ₄	1045218
3-yearly maintenance set, 115 V	CDLb 55, CDLb 41 H ₂ SO ₄	1045222



1.3 Bello Zon Chlorine Dioxide Systems

For CDLb with 30 l receiver module without pump

	Type	Order no.
Annual maintenance kit, 230 V	CDLb 06, CDLb 12, CDLb 08 H ₂ SO ₄	1044499
Annual maintenance kit, 230 V	CDLb 22, CDLb 16 H ₂ SO ₄	1044507
Annual maintenance kit, 230 V	CDLb 55, CDLb 41 H ₂ SO ₄	1044515
Annual maintenance kit, 230 V	CDLb 120, CDLb 89 H ₂ SO ₄	1044517
Annual maintenance kit, 115 V	CDLb 06, CDLb 12, CDLb 08 H ₂ SO ₄	1079201
Annual maintenance kit, 115 V	CDLb 22, CDLb 16 H ₂ SO ₄	1079205
Annual maintenance kit, 115 V	CDLb 55, CDLb 41 H ₂ SO ₄	1079209
3-yearly maintenance set, 230 V	CDLb 06, CDLb 12, CDLb 08 H ₂ SO ₄	1044500
3-yearly maintenance set, 230 V	CDLb 22, CDLb 16 H ₂ SO ₄	1044508
3-yearly maintenance set, 230 V	CDLb 55, CDLb 41 H ₂ SO ₄	1044516
3-yearly maintenance set, 230 V	CDLb 120, CDLb 89 H ₂ SO ₄	1044519
3-yearly maintenance set, 115 V	CDLb 06, CDLb 12, CDLb 08 H ₂ SO ₄	1045215
3-yearly maintenance set, 115 V	CDLb 22, CDLb 16 H ₂ SO ₄	1045219
3-yearly maintenance kit, from 09/15	CDLb 55, CDLb 41 H ₂ SO ₄	1045223
3-yearly maintenance kit, from 09/15	CDLb 120, CDLb 89 H ₂ SO ₄	1079243



1.3 Bello Zon Chlorine Dioxide Systems

1.3.6 Chlorine Dioxide System Bello Zon CDLb with Multiple Points of Injection

The modular customised solution for several ClO₂ points of injection with only one generation system.
 0 – 120 g/h capacity with storage of up to 60 g of chlorine dioxide for peak metering. Max. flow rate at 0.2 ppm ClO₂ metering capacity of 600 m³/h, up to 6 points of injection possible as standard



Flexible solutions for the production and metering of ClO₂ adapted to our customer's tasks, requirements and anticipated pricing.

Chlorine dioxide systems Bello Zon for multiple metering are divided into three different concepts, enabling them to respond perfectly to our customers' demands. These concepts are used where several injection points need to be supplied with ClO₂ from a single ClO₂ system. Up to 6 points of injection can be selected as standard depending on the chosen concept.

Concept 2 (assembly kit of metering components pre-assembled on panel)

This concept consists of two main components, the CDLb system and a metering panel, on which all the metering components are mechanically and, optionally, electrically pre-assembled.

Concept 3 (plug and play on stainless steel frame)

This concept consists of a stainless steel frame, on which the Bello Zon CDLb system and the metering components are mechanically and electrically mounted in full. There is a stainless steel control cabinet with a main switch that contains the central power supply and control system for all electrical components.

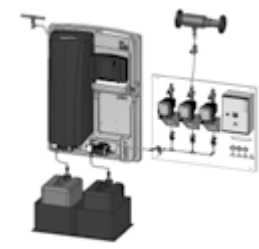

Concept 2

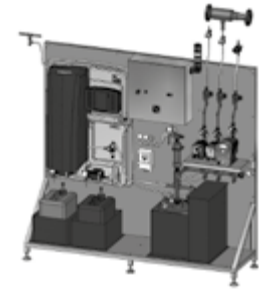

Concept 3



Your Benefits

- Provision of several points of injection according to requirements
- Outstanding operating safety and reliability thanks to intrinsically safe process control
- Ultra-simple process integration
- System monitoring in real-time from any location via the DULCONNEX Platform: Improved process reliability. Reliability and transparency thanks to real-time monitoring, individual alarms and automated reports.

Technical Details

- External storage module
- Internal storage tank (only with the 'Modular, loose components' and 'Modular, metering components pre-assembled on a panel' concepts)
- Terminal box with optional main switch (only with the 'Modular, metering components pre-assembled on a panel' concept)
- Stainless steel cabinet with main switch and emergency relay (only with the 'Plug and Play on stainless steel frame' concept)

Field of Application

- All applications which require more than one point of injection
- Disinfection in the food and beverage industry. Especially with bottle rinsers, CIP (cleaning in place), bottle washing machine and in fruit/vegetable washing
- Legionella control and prevention, e.g. in hotels or hospitals (cold and hot water metering)
- Market gardening: germ-free irrigation and sprinkler irrigation water
- Treatment of cooling water and potable water
- Filter disinfection, e.g. in swimming pools

1.3 Bello Zon Chlorine Dioxide Systems

1.3.7 Chlorine Dioxide System Bello Zon CDEb

Bello Zon CDEb impresses customers with its simple operation and clear construction.

5-200 g/h chlorine dioxide. Max. flow at 0.2 ppm ClO₂ metering is 1,000 m³/h



Chlorine dioxide system, which continuously produces ClO₂ according to the acid/chlorite method with diluted chemicals. Extremely simple operation, clear construction, analogue control, manual control or via contacts.



A ready-to-use chlorine dioxide system for the continuous production and metering of chlorine dioxide with diluted chemicals. The emphasis is on simple operation and clearly laid out system design with standard components.

The stroke lengths of the metering pumps are continuously monitored. This rules out inadmissible operating statuses arising from incorrect pump stroke length adjustments.

The system is extremely easy to operate and, alongside a central Start-Stop key, also has colour-differentiated LEDs to display all the operating statuses.

The system can be controlled in an analogue or manual manner or via contacts

Your Benefits

- Minimal training required thanks to extremely simple operation
- Low investment costs
- Short delivery times
- Simple process integration

Technical Details

- **Power supply**
 - 100-230 V, 50/60 Hz
- **Inputs**
 - 1 digital input for the Pause function
 - 1 digital input for contact water meter 0.25-20 Hz
 - 1 analogue input 0/4-20mA
- **Outputs**
 - 1 alarm signal relay
 - 1 warning signal relay
- **Operating substances**
 - 7.5% sodium chlorite, purity according to EN 938
 - 9% hydrochloric acid, purity according to EN 939
 - Particle-free water
- **Degree of protection**
 - IP 54
- **Bypass pipework**
 - DN 20

Field of Application

- Municipal potable water and wastewater treatment
- Industrial process and cooling water
- Disinfection in the food and beverage industry

1.3 Bello Zon Chlorine Dioxide Systems

Technical Data

Type	Chlorine dioxide metering rate (min.... max./hour, min./day)*		Max. operating pressure**	Operating temperature	Connection dimensions of chlorite and acid metering pumps	Dimensions H x W x D	Dimensions of the bypass connector	Weight
	g/h	g/d						
CDEb 30	5...30	10	7 / 8 ***	15...40	6x4	958 x 700 x 250	20	23
CDEb 75	10...75	20	7 / 8 ***	15...40	6x4	958 x 700 x 250	20	24
CDEb 200	20...200	40	7 / 8 ***	15...40	8x5	958 x 700 x 250	20	27

* The metering figures relate to 5 bar back pressure and an ambient temperature of 20 °C. The minimum capacity per hour is based on the fact that when the system is operating at below 10% of the nominal capacity, continuous metering is no longer possible due to the fact that the metering pumps then have a low pumping frequency. Where systems are operating continuously, the reactor content should be changed at least 2 x daily. Therefore, do not operate the system below the stated minimum capacity/day.

** Plus 2 bar from the resistance of the spring-loaded check valves = 10 bar (pump spring)

*** 8 bar at maximum 35 °C ambient temperature

Subject to technical and design changes

	Order no.
CDEb 30	1079438
CDEb 75	1079439
CDEb 200	1079440

Scope of supply:

Bello Zon CDEb systems are supplied connection-ready on a wall panel. Connection to the site bypass line is via DN 20 PVC threaded connectors with straight solvent unions. Order suction lances for the chemical pumps, safety collecting pans for the chemical drums and other accessories, like flushing equipment with a vacuum relief valve separately.



1.3 Bello Zon Chlorine Dioxide Systems

1.3.8 Chlorine Dioxide System Bello Zon CDVd

Chlorine dioxide system Bello Zon CDVd is for the treatment of medium to large volumes of water with diluted chemicals.

2.5 – 2,000 g/h chlorine dioxide. Maximum volume of water that can be treated with metering of 0.2 ppm ClO_2 , depending on the size of the system: 50 - 10,000 m³/h



Chlorine dioxide system for the metering of chlorine dioxide with diluted starting chemicals. The certified yield guarantees efficient chlorine dioxide production. Bello Zon CDVd can be easily and safely integrated into any water treatment process.

The chlorine dioxide system CDVd is very user-friendly. The system control offers impressive and intuitive menu navigation and ensures the precise production of chlorine dioxide. The special reactor concept generates chlorine dioxide safely and simply. You benefit from maximum yield with the lowest possible consumption of chemicals and maximum operating safety. Communication via conventional bus systems and our DULCONNEX Platform fulfils all the requirements set by the Industry 4.0 standards of tomorrow.

The system also meets all the requirements of the DVGW specifications W 224 and W 624 with regard to construction and operation and is intended for operation with diluted chemicals Bello Zon chlorite (7.5% NaClO_2) and acid (9% HCl). The liquid levels of the starting chemicals can either be displayed and monitored by external liquid level sensors or by adaptive liquid level monitoring for which a patent has been applied.



Your Benefits

- Highest operating safety and purity of the ClO_2 produced
- Communication interfaces via bus systems and DULCONNEX
- Monitoring of starting feed chemical tanks thanks to precise level indicators and measuring via radar sensors
- Verification of the chlorine dioxide metering and system output: For consumption levels which can be planned and enhanced system availability
- Configurable alarms and automatically generated reports: For simplified compliance with documentation obligations and to demonstrate correct operation
- Remote monitoring of systems in potentially dangerous environments.

Technical Details

Power supply

- 100-230 V, 50/60 Hz

Inputs

- 4 analogue inputs (0/4-20 mA)
- Water flow
- Control variable
- Acid level
- Chlorite level
- 4 digital inputs
- Contact water meter 0.25-20 Hz
- Pause
- Alternative metering
- External fault

Outputs

- 1 operating signal relay
- 1 alarm signal relay
- 1 warning signal relay
- Mains output for control of the bypass pump
- 2 freely configurable analogue outputs (0/4-20 mA)

Operating substances

- 7.5% sodium chlorite, purity according to EN 938
- 9% hydrochloric acid, purity according to EN 939
- Particle-free water

Degree of protection

- IP 65

1.3 Bello Zon Chlorine Dioxide Systems

Bus communication options

- Modbus TCP / DULCONNEX
- Modbus RTU / DULCONNEX
- Profibus DULCONNEX
- Profinet DULCONNEX

Field of Application

- Municipal drinking water and wastewater treatment
- Industrial process and cooling water
- Disinfection in the food and beverage industry, inlet water treatment

Technical Data

Type	Chlorine dioxide metering rate (min....max./hour, min./day)*		Max. operating pressure**	Operating temperature	Suction-side connector dimension of calibration vessels		Dimensions of the bypass connector DN
	g/h	g/d			bar	°C	
CDVd 45	2.5...45	16	8	10...40	6x4	6x4	25
CDVd 120	6...120	40	8	10...40	6x4	6x4	25
CDVd 240	12...240	80	8	10...40	8x5	8x5	25
CDVd 600	30...600	140	8	15...40	12x9	12x9	25
CDVd 2000	100...2,000	468	5	15...40	Pressure hose nozzle d16	Pressure hose nozzle d16	40

* The metering figures relate to 5 or 2 bar back pressure and an ambient temperature of 20 °C. The minimum capacity/hour is based on the fact that when the system is operating at below 5 % of the nominal capacity, continuous metering is no longer possible due to the fact that the metering pumps then have a low pumping frequency. The reactor contents should be changed at least twice daily with systems that do not work continuously. Therefore, do not operate the system below the stated minimum capacity/day.

** at an ambient temperature of 35 °C

Type	Dimensions H x W x D*	Weight	Supply voltage 230 V**	Supply voltage 115 V**	Power consumption without bypass pump	Power consumption with bypass pump	HCl (9%)***	NaClO ₂ (7.5%)***
CDVd 45	1,300 x 1,000 x 250	55	3.8	1.6	100	630	1.1	1.1
CDVd 120	1,300 x 1,000 x 250	55	3.9	1.6	110	640	2.9	2.9
CDVd 240	1,300 x 1,000 x 250	59	3.9	1.8	120	650	5.7	5.7
CDVd 600	1,525 x 1,160 x 253	84	4.0	1.9	220	750	14.3	14.3
CDVd 2000	2,000 x 1,320 x 290	129	-	2.6	300	-	47.6	47.6

* including main system, pre-dilution and rinse valve, without bypass pump and water feed section

** 230 V figures with bypass pump, 115 V figures without bypass pump

*** Sodium chlorite (NaClO₂) 24.5 %, purity in accordance with EN 938, hydrochloric acid 25-36%, purity in accordance with EN 939. The chemical consumption may vary depending on the temperature.

Ambient conditions:

Permissible relative air humidity (non-condensing)	max. 85% rel.
Permissible ambient temperature	40 °C
Permissible temperature of chemicals	10 ... 35 °C
Storage and transport temperature	-10 ... +40 °C
Degree of protection	IP 65



1.3 Bello Zon Chlorine Dioxide Systems

Identity code ordering system for CDVd systems

CDVd	Capacity	
	45	CDVd 45 g/h
	120	CDVd 120 g/h
	240	CDVd 240 g/h
	600	CDVd 600 g/h
	2000	CDVd 2000 g/h
		Version
	P	ProMinent
		Bypass version
	0	Without bypass
	1	Bypass PVC-U without bypass pump
	2	PVC-U bypass 230 V / 50 Hz with bypass pump (only up to 600 g/h)
	3	Bypass in USA design with ASI connections and unit in gpm, without bypass pump (only up to 600 g/h)
	4	Bypass for the secure filling of a buffer tank with 24 V valve and water meter, without buffer tank / without bypass pump (CDVd 240 + 600)
	5	Bypass for the secure filling of a buffer tank, with 30 litre buffer tank, without bypass pump (CDVd 120 - 600 g/h)
	6	Bypass for the secure filling of a buffer tank with 24 V valve and water meter, with 150 litre buffer tank, without bypass pump (CDVd 120 - 2,000 g/h)
		Suction lance, suction assembly for chemicals
	0	None
	1	Suction lance for 5 ... 60 l storage tank
	2	Suction lance for 200 l storage tank
	3	Flexible suction assembly up to 5 m with two-stage level switch
	4	Suction lance for 25 l storage tank with two 40 l collection pans without leak sensor. Leak sensors should be ordered using order no. 1031592 if required. Collection pans are prepared with collectors.
		Preset language
	DE	German
	EN	English
	FR	French
	IT	Italian
	ES	Spanish
		Analogue input/output
	0	None
	1	With input/output
	2	With input/output and with level measurement for chlorite + acid via radar sensors
		Bus communication
	0	None
	1	Modbus TCP
	2	Modbus RTU
	3	PROFIBUS® DP
	4	PROFINET
	5	Modbus TCP / DULCONNEX
	6	Modbus RTU / DULCONNEX
	7	PROFIBUS® / DULCONNEX
	8	PROFINET / DULCONNEX



1.3 Bello Zon Chlorine Dioxide Systems

Maintenance Sets for Bello Zon CDV Chlorine Dioxide Systems

The maintenance kits contain all wear parts that have to be replaced within the scope of regular system maintenance.

Maintenance kits for CDVd plants

	Order no.
Maintenance kit, complete CDVd 45	1105948
Maintenance kit, complete CDVd 120	1105949
Maintenance kit, complete CDVd 240	1105950
Maintenance kit, complete CDVd 600	1105951
Maintenance kit, complete CDVd 2000	1105952

Maintenance kits for CDVc plants

	Order no.
Maintenance set, complete CDVc 20	1034758
Maintenance set, complete CDVc 45	1034759
Maintenance set, complete CDVc 120	1034760
Maintenance set, complete CDVc 240	1034761
Maintenance set, complete CDVc 600	1034762
Maintenance kit, complete CDVc 2000 up to delivery date 03/2011	1034763
Maintenance kit, complete CDVc 2000 from delivery date 04/2011	1048801

Maintenance kits for CDVb plants

	Order no.
Maintenance set, complete CDVb 15	1022252
Maintenance set, complete CDVb 35	1022253
Maintenance set, complete CDVb 60	1022264
Maintenance set, complete CDVb 120	1022265
Maintenance set, complete CDVb 220	1024614

Additional spare parts are listed in the operating instructions for the systems.



1.3 Bello Zon Chlorine Dioxide Systems

1.3.9 Chlorine Dioxide System Bello Zon CDKd

Chlorine dioxide system Bello Zon CDKd treats medium to large volumes of water with concentrated chemicals.

7.5 – 12,000 g/h chlorine dioxide. Maximum volume of water that can be treated with metering of 0.2 ppm ClO_2 , depending on the size of the system: 60,000 m³/h



Chlorine dioxide system for the metering of chlorine dioxide with concentrated starting chemicals. The proven safety concept protects people and the environment. The certified yield guarantees efficient chlorine dioxide production. Bello Zon CDKd can be easily and safely integrated into any water treatment process.



In the chlorine dioxide system there is an intrinsically safe pre-dilution station for concentrated hydrochloric acid. The consumption of hydrochloric acid can therefore be automatically adapted on-site to the individual operating conditions by means of a patent-pending process.

The system control offers impressive and user-friendly menu navigation and ensures the precise production of chlorine dioxide. The chemicals are mixed perfectly in a reactor made of food-safe PVDF. You thereby benefit from maximum yield with the lowest possible consumption of chemicals and maximum operating safety. The requirements set by the Industry 4.0 standards of tomorrow are met thanks to communication via popular bus systems and our DULCONNEX Platform.

The construction and operating mode of the system also complies with all requirements of DVGW specifications W 224 and W 624 and the system is intended for operation with concentrated chemicals Bello Zon chlorite (24.5% NaClO_2) and acid (25 – 37% HCl). The liquid levels of the starting chemicals can either be displayed and monitored by external liquid level sensors or by adaptive liquid level monitoring for which a patent has been applied.

Your Benefits

- Cost savings through optimised acid consumption
- Communication interfaces via bus systems and DULCONNEX
- Monitoring of starting feed chemical tanks thanks to precise level indicators
- Consumption levels can be planned, enhanced availability and economical operation thanks to verification of chlorine dioxide metering and system output
- Configurable alarms and automatically generated reports: For simplified compliance with documentation obligations and to demonstrate correct operation
- Remote monitoring of systems in potentially dangerous environments



Technical Details

Power supply

- 100-230 V, 50/60 Hz

Inputs

- 4 analogue inputs (0/4-20 mA)
- Water flow
- Control variable
- Acid level
- Chlorite level
- 4 digital inputs
- Contact water meter 0.25-20 Hz
- Pause
- Alternative metering
- External fault

Outputs

- 1 operating signal relay
- 1 alarm signal relay
- 1 warning signal relay
- Mains output for control of the bypass pump
- 2 freely configurable analogue outputs (0/4-20 mA)

Operating substances

- 24.5% sodium chlorite, purity according to EN 938
- 25-37 % hydrochloric acid, purity according to EN 939
- Particle-free water

1.3 Bello Zon Chlorine Dioxide Systems

Degree of protection

- IP 65

Bus communication options

- Modbus TCP
- Modbus RTU
- Profibus
- Profinet
- DULCONNEX

Field of Application

- Municipal drinking water and wastewater treatment
- Industrial process and cooling water

1.3 Bello Zon Chlorine Dioxide Systems

Technical Data

Type	Chlorine dioxide metering rate (min....max./hour, min./day)*		Max. operating pressure**	Operating temperature	Suction-side connector dimension of calibration vessels		Dimensions of the bypass connector DN
	g/h	g/d			bar	°C	
CDKd 150	7.5...150	56	8	10...40	8x5	6x4	25
CDKd 400	20...400	140	8	10...40	12x9	8x5	25
CDKd 900	45...900	300	8	10...40	Pressure hose nozzle d16	8x5	25
CDKd 2000	100...2,000	700	5	10...40	Pressure hose nozzle d20	12x9	40
CDKd 2800	140...2,800	700	5	15...40	Pressure hose nozzle d20	12x9	40
CDKd 7300	370...7,300	1750	3	15...40	Pressure hose nozzle d32	Pressure hose nozzle d16	40
CDKd 12000	600...12,000	1750	2	18...40	Pressure hose nozzle d32	Pressure hose nozzle d16	40

* The metering figures relate to 5 or 2 bar back pressure and an ambient temperature of 20 °C. The minimum capacity/hour is based on the fact that when the system is operating at below 5 % of the nominal capacity, continuous metering is no longer possible due to the fact that the metering pumps then have a low pumping frequency. The reactor contents should be changed at least twice daily with systems that do not work continuously. Therefore, do not operate the system below the stated minimum capacity/day.

** at an ambient temperature of 35 °C

Type	Dimensions H x W x D (approx.)*		Weight	Supply voltage 230 V**	Supply voltage 115 V**	Power consumption without bypass pump	Power consumption with bypass pump	HCl (30 %)**	NaClO ₂ (24.5 %)**
	mm	kg							
CDKd 150	1,300 x 1,000 x 250	89		3.9	1.7	110	640	0.9	0.9
CDKd 400	1,675 x 900 x 460	119		3.9	1.8	160	690	2.5	2.5
CDKd 900	1,920 x 920 x 520	131		4.2	2.3	210	740	5.6	5.6
CDKd 2000	1,880 x 1,320 x 570	201		-	3.7	370	-	12.3	12.3
CDKd 2800	1,880 x 1,320 x 570	201		-	3.7	370	-	17.3	17.3
CDKd 7300	2,250 x 1,850 x 500	216		-	8.6	610	-	45.1	45.1
CDKd 12000	2,250 x 1,850 x 500	216		-	8.6	610	-	74.1	74.1

* including main system, pre-dilution and rinse valve, without bypass pump and water feed section

** 230 V figures with bypass pump, 115 V figures without bypass pump

*** Sodium chlorite (NaClO₂) 24.5 %, purity in accordance with EN 938, hydrochloric acid 25-36%, purity in accordance with EN 939. The chemical consumption may vary depending on the temperature. The hydrochloric acid consumption is calculated for a concentration of 30%. Up to 25% hydrochloric acid can be saved with the aid of automatic acid adjustment.

Ambient conditions:

Permissible relative air humidity (non-condensing)	max. 85% rel.
Permissible ambient temperature	40 °C
Permissible temperature of chemicals	10 ... 35 °C
Storage and transport temperature	-10 ... +40 °C
Degree of protection	IP 65



1.3 Bello Zon Chlorine Dioxide Systems

Identity code ordering system for CDKd systems

CDKd	Capacity	
150	CDKd 150 g/h	
400	CDKd 400 g/h	
900	CDKd 900 g/h	
2000	CDKd 2,000 g/h	
2800	CDKd 2,800 g/h	
7300	CDKd 7,300 g/h	
12000	CDKd 12,000 g/h	
Version		
P	ProMinent	
Bypass version		
0	Without bypass	
1	Bypass PVC-U without bypass pump	
2	PVC-U bypass with 230 V / 50 Hz bypass pump (CDKd 150 - 900 g/h)	
4	Bypass for the secure filling of a buffer tank with 24 V valve and water meter, without buffer tank / without bypass pump (CDKd 150 - 2,800 g/h)	
5	Bypass for the secure filling of a buffer tank, with 30 litre buffer tank, without bypass pump (CDKd 150 - 900 g/h)	
6	Bypass for the secure filling of a buffer tank with 24 V valve and water meter, with 150 litre buffer tank, without bypass pump (CDKd 150 - 2,800 g/h)	
Suction lance, suction assembly for chemicals		
0	None	
1	Variable suction lance for 200 l storage tank, gas-tight, with a second acid lock (storage tank height 500 ... 700 mm)	
2	Flexible suction assembly up to 5 m for IBC storage tanks with two-stage level switch, with a second acid lock	
Preset language		
DE	German	
EN	English	
FR	French	
IT	Italian	
ES	Spanish	
Analogue level measurement		
0	None	
1	With input/output	
2	With input/output and with level measurement for chlorite + acid	
3	With input/output, including adaptive acid adjustment (Pt 1000)	
4	With input/output and with level measurement for chlorite + acid, including adaptive acid adjustment (Pt 1000)	
Bus communication		
0	None	
1	Modbus TCP	
2	Modbus RTU	
3	PROFIBUS®	
4	PROFINET	
5	Modbus TCP / DULCONNEX	
6	Modbus RTU / DULCONNEX	
7	PROFIBUS® / DULCONNEX	
8	PROFINET / DULCONNEX	



1.3 Bello Zon Chlorine Dioxide Systems

Maintenance kits for Bello Zon chlorine dioxide systems type CDKd

The spare parts kits include all wearing parts that need replacing in the course of regular maintenance.

	Order no.
Maintenance kit, complete CDKd 150	1105953
Maintenance kit, complete CDKd 400	1105954
Maintenance kit, complete CDKd 900	1105955
Maintenance kit, complete CDKd 2000	1105956
Maintenance kit, complete CDKd 2800	1105957
Maintenance kit, complete CDKd 7300	1105958
Maintenance kit, complete CDKd 12000	1105959

Additional spare parts are listed in the operating instructions for the systems.

Maintenance Kits for Bello Zon Type CDK Chlorine Dioxide Systems

The spare parts kits include all wearing parts that need replacing in the course of regular maintenance.

	Order no.
Maintenance kit, complete CDKc 150 (type 20)	1043841
Maintenance kit, complete CDKc 170 (type 02)	1036454
Maintenance kit, complete CDKc 400 (type 21)	1043842
Maintenance kit, complete CDKc 420 (type 04)	1036455
Maintenance kit, complete CDKc 900 (type 22)	1043843
Maintenance kit, complete CDKc 900 (type 06)	1036456
Maintenance kit, complete CDKc 2000 (type 23)	1043864
Maintenance kit, complete CDKc 2100 (type 08)	1036457
Maintenance kit, complete CDKc 2800 (type 24)	1043865
Maintenance kit, complete CDKc 3000 (type 10)	1036458
Maintenance kit, complete CDKc 7500 (type 25)	1043866
Maintenance kit, complete CDKc 7500 (type 12)	1036459
Maintenance kit, complete CDKc 12000 (type 26)	1043867
Maintenance kit, complete CDKc 12000 (type 14)	1040079

Additional spare parts are listed in the operating instructions for the systems.



1.3 Bello Zon Chlorine Dioxide Systems

1.3.10 Storage Tank Accessories



External storage module CDVd/CDKd

The large chlorine dioxide storage module with integrated volume compensation bag

Useful capacity 150 l

The external storage module features a volume compensation bag so that no external bleed line or neutralisation of the chlorine dioxide gas volume is needed.

The maximum permissible concentration of the ClO₂ solution is 2,000 mg/l.

The benefits for you

The buffer tank can be connected on a project basis to the chlorine dioxide systems Bello Zon CDVd and CDKd. Make sure that the defined safety equipment (secure bypass) is also installed. Please contact our Sales Department with any project enquiries. The external buffer tank can be used in applications where more than one point of injection is needed.

	Dimensions L x W x H mm	Extraction	Filling	Order no.
Storage module 150 l for BelloZon®	1,300 x 685 x 1,290	2 x DN 32	1 x DN 25	1060153

1.3 Bello Zon Chlorine Dioxide Systems

1.3.11

Bypass Line Accessories

1

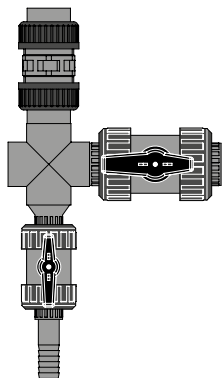

Flushing Assembly

Install a flushing valve downstream of the chlorine dioxide system so that the reactor and pre-mixer can be flushed through, either for maintenance purposes or after a long system shutdown. The complete flushing equipment kit comprises a DN 20 or DN 25 PVC stopcock and a DN 15 PVC flushing valve with a hose nozzle and a DN 25 vacuum relief valve. It is already included as standard in the scope of supply of all new systems.

	Order no.
Flushing equipment PVC-U, EPDM, DN 20 for CDE	1047718
Flushing equipment PVC-U, EPDM, DN 25 for CDV, CDK	1033405

Ball-check Valve

A back pressure-resistant ball-check valve should be fitted on installations with long bypass lines, especially if the pipe slopes downwards and the point of injection is below the Bello Zon system, as well as on installations with fluctuating back pressure.

	Nominal diameter	Connec- tion size	Mate- rial	Order no.
Back pressure valve/relief valve type DHV-U, PCB design, DN 20 connection	DN 20	G 1 1/4"	PCB Version	1037775
Back pressure valve/relief valve type DHV-U, PCB design, DN 25 connection	DN 25	G 1 1/2"	PCB Version	1037774
Back pressure valve DHV 712-R DN 40 G 2 1/4" PCB	DN 40	G 2 1/4"	PCB Version	1000052

PVC-U Chlorine Dioxide Point of Injection

Use an immersion pipe for homogeneous distribution of the chlorine dioxide enriched bypass water in the main water supply pipe, to optimise the mixing and distribution of the chlorine dioxide. Shorten the immersion pipe on-site to the required length. The scope of delivery includes a ball valve DN 25 as a shut-off valve for this purpose. The immersion pipe is installed using a DN 50 DIN flange supplied by others.

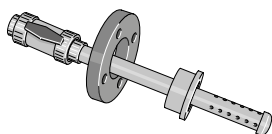

	Order no.
Injection pipe for pipe diameters up to DN 80	1018754
Injection pipe for pipe diameters from DN 100	1018753



1.3 Bello Zon Chlorine Dioxide Systems

1.3.12 Chemical Supply Accessories

Suction Lances and Accessories

Suction lances have a rigid construction that can be precisely adapted to the chemical tank. Suction assemblies consist of flexible suction lines.

All suction lances and suction assemblies are made of PVC with FKM seals and are fitted with a foot valve and two-stage level switch including cable and round plug. Select relevant components from the ProMinent motor-driven metering pump accessories range for system types not listed here.

	Suitable for system types	Order no.
Suction lance for connection to 5-60 litre non-reusable tank with 2 m long suction hose (6/4 mm)	CDVd 45-120, CDEb 30-75	802077
Suction lance for connection to 5-60 litre non-reusable tank with 2 m long suction hose (6/4 mm)	CDLb	790650
Suction lance for connection to 5-60 litre non-reusable tank with 2 m long suction hose (8/5 mm)	CDVd 240-600, CDEb 200	802078
Suction lance for connection to 200 litre drums with 3 m long suction hose (6/4 mm)	CDVd 45-120, CDEb 30-75	802079
Suction lance for connection to 200 litre drums with 3 m long suction hose (6/4 mm)	CDLb	791563
Suction lance for connection to 200 litre drums with 3 m long suction hose (8/5 mm)	CDVd 240-600, CDEb 200	802080
Flexible suction fitting with D55 screw cap and 5 m suction hose (6/4mm)	CDVd 45-120, CDEb 30-75	1034602
Flexible suction fitting with D55 screw cap and 5 m suction hose (8/5 mm)	CDVd 240-600, CDEb 200	1034644
Suction lance DN 25 PP for connection to 200 litre drums, excluding cable	CDVd 2000	1039397
Suction lance DN 25 PP for connection to 1,000 litre IBC container, excluding cable	CDVd 2000	1039399
Gas-tight suction lance for 200 litre drums with bleed valve, connection for 6/4 and 8/5 mm suction lines and connector for 6/4 mm return line	CDKd 150-2800	1036371
Gas-tight suction lance for 60-litre canister with bleed valve, connector for 6/4 and 8/5 mm suction line and connector for 6/4 mm return line	CDKd 150-2800	1030891
Flexible suction assembly with 5 m suction hose (6/4 mm) and gas-tight D55 screw cap with opening for a return line	CDKd 150-2800	1036174
Flexible suction assembly with 5 m suction hose (8/5 mm) and gas-tight D55 screw cap with opening for a return line	CDKd 150-2800	1036175

1.3 Bello Zon Chlorine Dioxide Systems

Safety collecting pan for chemical tanks (CDLb)

Usable capacity	Version	Order no.
40	Without leakage monitor	791726
40	With leakage monitor	791728
70	Without leakage monitor	740309
70	With leakage monitor	740308
140	Without leakage monitor	740723
140	With leakage monitor	1003190

Scope of delivery:

- Without leak monitoring: one tray
- With leak monitoring: two trays + level switch + electronics card for Bello Zon control

1.3 Bello Zon Chlorine Dioxide Systems

1.3.13

Safety Accessories and Analysis

Gas detector GMA 22 chlorine dioxide

The GMA 22 chlorine dioxide gas detector is designed as a compact measuring and switching unit for monitoring the ambient air for dangerous concentrations of chlorine dioxide.



Type GMA 22	Chlorine dioxide
Warning at approx.	0.2 ppm/vol%
Alarm at approx.	1.0 ppm/vol%
Permissible ambient temperature	0...45 °C
Protection class housing	IP 64
Dimensions (without PGs, without sensor) H x W x D	140 x 97 x 50 mm mm
Supply	100 – 240 V AC / 50 – 60 Hz
DC power connection	20 - 30 V DC
Max. power consumption incl. sensor	20 W
Warm-up phase max.	150 s
'Warning' relay contact, latching	250 V ; 3 A
'Alarm' relay contact, latching	250 V ; 3 A
'Horn' relay contact, latching, can be acknowledged	250 V ; 3 A
Sensor measuring principle	electrochemical
Maximum sensor life	2 a

	Order no.
Gas detector GMA 22/1, 230 V including 1 transmitter with ClO ₂ sensor and 10 m connecting cable	1117291
Gas detector GMA 22/1, 24 V DC including 1 transmitter with ClO ₂ sensor and 10 m connecting cable	1117304
Gas detector GMA 22/2, 230 V including 2 transmitters with ClO ₂ sensor and 10 m connecting cable	1117308
Gas detector GMA 22/2, 24 V DC including 2 transmitters with ClO ₂ sensor and 10 m connecting cable	1117311
Replacement sensor for chlorine, chlorine dioxide, ozone *	1117331

* Sensor storage at 4 °C... 10 °C

Accessories for connecting a second sensor

	Order no.
Connecting cable 5x0.25 mm ² 10 m	1117330



1.3 Bello Zon Chlorine Dioxide Systems



Flash light-horn

Combined horn and red warning lamp. IP 65 housing made of impact-resistant grey polycarbonate with a transparent polycarbonate dome. Rating values: 230 V AC, 50 mA.

	Order no.
Flash light-horn, red with continuous tone	1083160

Warning Label for Chlorine Dioxide System

Soft PVC film, yellow/black, 300 x 200 mm, self-adhesive.

	Language	Order no.
'Behälter und Geräte nicht wechselweise benutzen'	German	607320
'Never mix up chemical containers'	English	607318
'Non usare serbatoi e apparecchi alternativamente'	Italian	791886

Warning Label for Chlorine Dioxide Room

PVC film yellow/black, 200 x 80 mm

	Language	Order no.
'Zutritt nur für unterwiesene Personen'	German	607322
'Entry for authorised persons only'	English	607319
'Vietato l'accesso ai non addetti ai lavori'	Italian	791885



1.3 Bello Zon Chlorine Dioxide Systems

Photometers DT1 and DT4

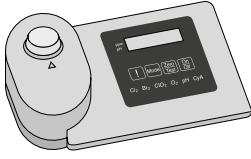

- Transportable, compact photometer
- Simple to operate with text support
- Safe, simple measurement of chlorine, chlorine dioxide, chlorite, H₂O₂, bromine, ozone, pH and cyanuric acid
- Can be calibrated

Measuring ranges of the DT1B	0.05 ... 6.0 mg/l free chlorine (DPD1) + total chlorine (DPD1+3) 5 ... 200 mg/l free chlorine (high range) 0.1 ... 13.0 mg/l bromine (DPD1) 0.05 ... 11 mg/l chlorine dioxide (DPD1) 0.03 ... 4.0 mg/l ozone (DPD4) 6.5 ... 8.4 pH (phenol red)
DT4B ranges	1 ... 80 mg/l cyanuric acid 0.03 ... 2.5 mg/l chlorite 0.05 ... 11 mg/l chlorine dioxide 0.05 ... 6 mg/l chlorine
Measuring tolerance	Dependent upon measured value and measuring method
Battery	4 AA/LR6 batteries
Min. ambient temperature	5 °C
Max. ambient temperature	40 °C
Relative humidity	30 ... 90% (non-condensing)
Material	Housing: ABS Keypad: Polycarbonate film
Dimensions L x W x H	190 x 110 x 55
Weight	0.4 kg

		Order no.
Photometer DT1B	Complete with carrying case	1039315
Photometer DT2C	Complete with carrying case	1039316
Photometer DT4B	Complete with carrying case	1039318

The standard delivery package for the photometers includes accessories, cuvettes and reagents

1.3 Bello Zon Chlorine Dioxide Systems

Consumables for Analysis

	Order no.
DPD1 tablets, 100 tablets	1115981
DPD3 tablets, 100 tablets	1115982
Glycine tablets, 20 pieces	1115983
Phenol red tablets 100 pieces	1116004
3 pieces replacement cuvettes; round cuvettes with lid for DPD, phenol red and cyanuric acid detection (DT1, DT1B, DT4, DT4B)	1007566
Chlorine dioxide tablets No. 1, 250 no.	1039732
Chlorine dioxide tablets No. 2, 250 no.	1039733
Chlorine HR tablets, 100 pieces	1075056
Acidifying tablets, 100 pieces	1075057

DPD reagents for measuring excess chlorine, ozone or chlorine dioxide in the water in combination with Lovibond comparator.

		Order no.
DPD tablets no. 1	100	501319
DPD tablets no. 2	100	501320
DPD tablets no. 3	100	501321
DPD tablets no. 4	100	501322



1.4 Electrolysis Systems CHLORINSITU and DULCOLYSE

1.4.1 Electrolysis Systems CHLORINSITU

With electrolysis, chlorine and sodium hydroxide solution are produced in situ from salt using electric current.

In the **open electrolysis cell** (type CHLORINSITU IIa), the electrochemical reaction takes place in a flow chamber, so that the freshly produced chlorine gas immediately reacts with the sodium hydroxide solution also produced to form sodium hypochlorite. The benefit of the open electrolysis cell lies in the simple construction of the equipment, its ease of maintenance and low investment compared to **membrane electrolysis systems**.

In **membrane electrolysis**, the electrochemical reaction takes place in two electrode chambers, separated by a diaphragm, so that the formation of the freshly produced chlorine gas and sodium hydroxide solution is physically separated. Systems of types CHLORINSITU III and CHLORINSITU III Compact bring the reaction mixtures of both electrode chambers together again after the electrochemical reaction to produce a stock solution of sodium hypochlorite (25 g/l FAC), which can be stored temporarily and metered as needed.

With systems of types CHLORINSITU IV Compact and CHLORINSITU V, the chlorine gas produced is fed directly into the water to be treated through an injector and under constant vacuum. It then dissolves as hypochlorous acid. In systems of type CHLORINSITU V Plus, any excess chlorine gas produced is combined with the sodium hydroxide solution, as in the CHLORINSITU III system, to form sodium hypochlorite and is then stored temporarily. The systems therefore only need to be designed for average chlorine demand, as peaks in capacity can be compensated for from the sodium hypochlorite supply tank. In all systems of types CHLORINSITU IV Compact, CHLORINSITU V and CHLORINSITU V Plus, the sodium hydroxide solution also produced during electrolysis is stored temporarily and metered in, as required, to correct the pH value.

The benefit of membrane systems lies in their excellent efficiency (85 % brine yield) and minimal entrainment of chloride compared to open electrolysis cells. In systems of types CHLORINSITU V and CHLORINSITU V Plus, the entrainment of chloride and chlorate from the electrolysis cell into the water to be treated can be avoided completely. In membrane cell electrolysis systems for producing sodium hypochlorite, the higher yield results in solutions with a significantly higher chlorine content than is the case with open electrolysis cells.

- Disinfection from natural sodium chloride
- No handling of hazardous chemicals
- High-purity product, thanks to production in situ and short temporary storage periods
- The chlorine gas is generated under a constant vacuum, absolutely reliably and with maximum operating safety, thanks to the devices being designed as vacuum systems
- Chlorine generation and pH correction with one system (CHLORINSITU IV Compact, CHLORINSITU V and CHLORINSITU V Plus)
- Improved working conditions for operating personnel

1.4 Electrolysis Systems CHLORINSITU and DULCOLYSE

1.4.2 Performance Overview of Electrolysis Systems

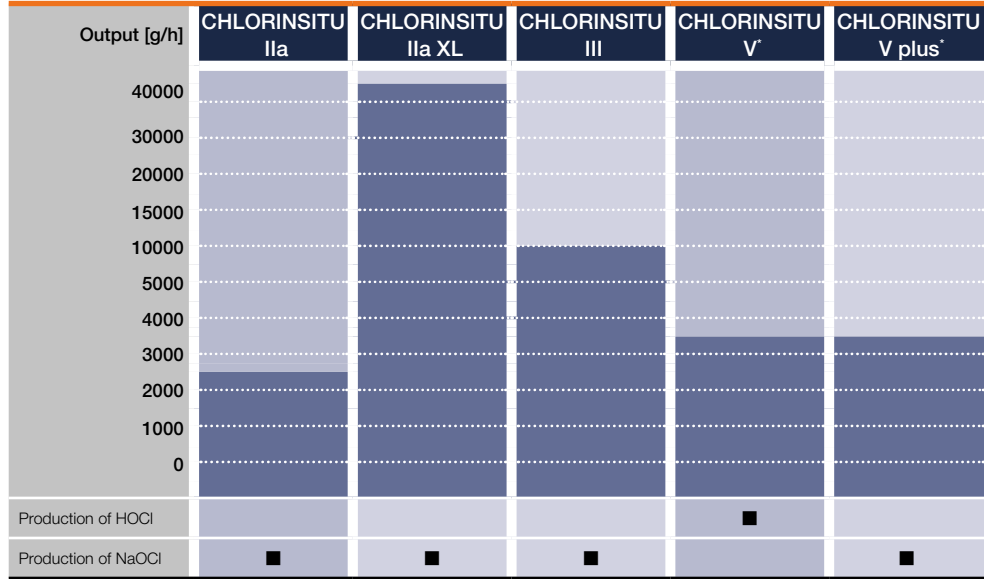

* Larger capacities available on request

Applications

Drinking water	■	■	■	■	■
Wastewater	■	■	■	■	■
Process water	■	■	■	■	■
Swimming pool water	■	■	■	■	■
Cooling tower			■	■	■

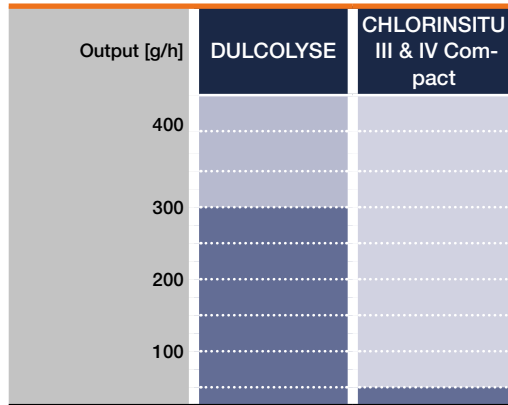

Applications

Food and beverage industry	■	
Drinking water		■
Cooling tower		■
		■

Note: larger systems available on request





1.4 Electrolysis Systems CHLORINSITU and DULCOLYSE

1.4.3 Questionnaire on the Design of an Electrolysis Plant

Use of the electrolysis system:

- For the disinfection of
 - Potable water
 - Industrial water
 - Cooling water
 - Swimming pool water
 - _____

Water values:

- Max. water flow _____ m³/h Maximum water pressure _____ bar
- Water flow constant fluctuating from _____ m³/h to _____ m³/h
- pH value _____ Iron (Fe²⁺) _____ mg/l
- Temperature _____ °C Manganese (Mn²⁺) _____ mg/l
- Solids proportion _____ mg/l Nitrite (NO₂⁻) _____ mg/l
- Acid capacity K_{S4,3} _____ mmol/l Sulphide (S²⁻) _____ mg/l
- Total hardness _____ mmol/l TOC (total organic carbon) _____ mg/l
- Total hardness _____ °dH Ammonium _____ mg/l

Number of points of injection: _____

- Type of metering:
- constant
 - flow-proportional
 - measured value-dependent

Required feed volume: _____ mg/l

Existing disinfection method: _____

Existing disinfection consumption: _____ kg/week

Other requirements:

1.4 Electrolysis Systems CHLORINSITU and DULCOLYSE

1.4.4 Electrolysis System CHLORINSITU IIa 60 – 2,500 g/h

Enhanced efficiency through innovative design.

Output 60 – 2,500 g/h of chlorine



CHLORINSITU IIa is a compact on-site electrolysis system for the production of a low-chlorate hypochlorite solution from salt and electricity. Key advantages are its simple process management and excellent system safety through integrated ventilation and bleeding.

The CHLORINSITU IIa product range combines the proven and durable design of the undivided electrolysis cell with an innovative design. An exceptional quality of hypochlorite solution is achieved when the salt and power output is increased. The chlorate content of the product is below the limit value specified in EN 901.

The electrolysis system is perfectly equipped for all safe water disinfection with a capacity of up to 2500 g of chlorine per hour.

All relevant system components are accommodated in a space-saving housing. Integrated hydrogen drainage enables the system to be installed without any need for additional ventilation.

The softener and a 50-litre product tank are installed in the system housing with systems up to 300 g/h. An integrated metering pump circulates the chlorine from the tank directly to the application or into a larger storage tank.

An H₂ deaerator dissolves the hydrogen directly from the hypochlorite with systems above 625 g/h. The hydrogen-free product is pumped by an integrated pump into an external product tank. The product pump is also capable of pumping across height differences of up to 7 m. Customised metering stations supply the points of injection.

The external product storage tank does not require additional hydrogen bleeding. There are therefore no additional costs relating to installation and operation.

The system is immediately ready for use, thanks to its plug-and-play concept. Operation of the electrolysis system has been consciously kept simple.

Your Benefits

- Durable design, reliable technology
- Low-chlorate product (below the EN 901 limit value)
- High output: only 3.0 kg of salt per kg of chlorine
- Reduced energy consumption: only 4 kWh/kg chlorine
- Minimal maintenance work and ease of operation
- System monitoring in real time from any location via DULCONNEX Platform: improved process reliability, overall reliability and transparency through real-time monitoring, individual alarms and automated reports (optional)



Technical Details

- Efficient undivided electrolysis cell
- Corrosion-proof housing with integrated ventilation fan
- Control with multicoloured touch panel
- Optional remote maintenance module
- Salt-dissolving tank included in the scope of delivery
- Integrated 50-litre product storage tank with optional diaphragm metering pump (up to 300 g/h)
- Integrated softener (up to 300 g/h)

Field of Application

- Potable water
- Swimming pool water
- Process water





1.4 Electrolysis Systems CHLORINSITU and DULCOLYSE

Technical Data

Power supply
 (60 – 300 g/h): 230 V AC ±10 %, 50/60 Hz
 (625 – 2,500 g/h): 3 x 230/400 V AC ±10 %, 50/60 Hz

Output		Number of electrolysis cells	Product volume (NaOCl) l/h	Power uptake kW	Max. salt consumption kg/h	Dimensions H x W x D mm	Brine tank l
g/h	kg/d						
60	1.4	1	7	0.5	0.19	1,950 x 750 x 644	200
120	2.8	2	14	0.8	0.38	1,950 x 750 x 644	200
180	4.2	3	21	1.1	0.57	1,950 x 750 x 644	200
240	5.6	4	28	1.4	0.75	1,950 x 750 x 644	200
300	7	5	35	1.7	0.95	1,950 x 750 x 644	200
625	15	1	75	3.4	1.9	1,850 x 1,500 x 620	200
1250	30	2	150	6.8	3.8	1,850 x 1,500 x 620	380
2500	60	1	300	12.8	7.5	1,850 x 1,500 x 620	520

All figures apply for 20 °C ambient temperature and 15 °C feed water. The performance of the system is affected by the temperature and quality of the water and salt.

Salt usage: 3.0 kg/kg chlorine
Energy efficiency: 4.0 kWh/kg chlorine
Product concentration: 9 g/l (0.9 % ±0.05) chlorine
pH value of product (approx.): 9.5
Salt specifications: CHLORINSITU salt, salt tablets or salt with a grain size of ≥ 6 mm, min. 99.4 % NaCl, max. 0.05 % insoluble substances, max. 10 mg/kg iron, max. 10 mg/kg manganese, max. 100 mg/kg calcium + magnesium
Inlet water temperature: 10...25 °C (lower/higher temperatures require a heater/chiller)
Water supply: 2 bar < pressure < 6 bar (drinking water quality)
Ambient conditions: Non-condensing, non-corrosive and dust-free ambient air in the installation room
Permissible relative air humidity: Max. 85 %
Permissible ambient temperature: 10...40 °C

1.4 Electrolysis Systems CHLORINSITU and DULCOLYSE

Identity Code Ordering System for Electrolysis Systems CHLORINSITU IIa

Clla	Type	Output
	0060	60 g/h
	0120	120 g/h
	0180	180 g/h
	0240	240 g/h
	0300	300 g/h
	0625	625 g/h
	1250	1,250 g/h
	2500	2,500 g/h
Version		
P	ProMinent Standard	
1	ProMinent with Siemens control (60 – 300 g/h)	
Mechanical design		
0	Standard	
M	Modified	
Electrical Connection		
0	230 V, 50/60 Hz	
2	3 ph, 400/230 V, 50 Hz	
Softener		
0	None (only 625- 2500 g/h)	
1	With	
Chlorine pump		
0	None	
1	With (60 – 300 g/h)	
Communication interfaces		
0	None	
1	Remote Engineer (including Smart View with Siemens control), selection for 60-2500 g/h	
3	Modbus TCP/IP, only with Siemens control (60-2500 g/h)	
4	Modbus RTU, only with Siemens control (60-2500 g/h)	
5	Profibus, only with Siemens control (60-2500 g/h)	
6	Siemens Put-Get, only with Siemens control (60-2500 g/h)	
A	Modbus TCP/IP + Remote Engineer, only with Siemens control (60-2500 g/h)	
B	Modbus RTU + Remote Engineer, only with Siemens control (60-2500 g/h)	
C	Profibus + Remote Engineer, only with Siemens control (60-2500 g/h)	
D	Siemens Put-Get + Remote Engineer, only with Siemens control (60-2500 g/h)	
Additional options		
0	None	
3	With transparent door (60 – 300 g/h)	
Preset language		
DE	German	
EN	English	
FR	French	
IT	Italian	
ES	Spanish	



1.4 Electrolysis Systems CHLORINSITU and DULCOLYSE

Maintenance sets for CHLORINSITU IIa

	Order no.
Maintenance set 1-year 60 g/h	1097435
Maintenance set 1-year 120 g/h	1097436
Maintenance set 1-year 180 g/h	1097437
Maintenance set 1-year 240 g/h	1097438
Maintenance set 1-year 300 g/h	1097439
Maintenance set 1-year 625 g/h	1108161
Maintenance set 1-year 1250 g/h	1108162
Maintenance set 1-year 2500 g/h	1108163
Maintenance set 3-years 60 g/h	1097440
Maintenance set 3-years 120 g/h	1097441
Maintenance set 3-years 180 g/h	1097442
Maintenance set 3-years 240 g/h	1097443
Maintenance set 3-years 300 g/h	1097455
Maintenance set 3-years 625 g/h	1108194
Maintenance set 3-years 1250 g/h	1108195
Maintenance set 3-years 2500 g/h	1108196

Spare parts for CHLORINSITU IIa

	Order no.
Electrolysis cell CIIa 60 g/h	1098825
Electrolysis cell CIIa 625 g/h	1108200
Electrolysis cell CIIa 2500 g/h	1108201



1.4 Electrolysis Systems CHLORINSITU and DULCOLYSE

1.4.5 Electrolysis System CHLORINSITU IIa XL

High-performance open cell electrolysis

Output 5 – 45 kg/h of chlorine



CHLORINSITU IIa XL is the tubular cell electrolysis system for on-site production of large quantities of hypochlorite. Users cannot fail to be impressed by its ease of operation and outstanding efficiency combined with optimum process stability for the reliable disinfection of large volumetric flows.

The new CHLORINSITU IIa XL is specially developed to meet the requirements of large-capacity in-situ potable water disinfection. Based on the robust tubular cells, the system is a modular system for the safe production of hypochlorite solution from a diluted salt solution. Thanks to its precise production and optimised cell design, it achieves a high turnover of salt at a concentration of 8 g/l in the final product. The certified safety concept ensures the safe extraction of hydrogen and maximum operating safety. The CIIa XL is combined with the necessary modules, depending on the needs of the project, and is adapted as best as possible to the conditions on-site.



Your Benefits

- Sole use of salt as the raw material
- Very long service lives due to minimal maintenance and robust technology
- Proven cell design with increased efficiency, only 3.2 kg NaCl/kg free chlorine
- Modular design
- Easy accessibility
- Certified safety
- Safe and reliable hydrogen discharge

Technical Details

Modular electrolysis system with project-specific additional components:

- Softener system
- Salt dissolving and supply
- Pre-dilution unit
- Cooling unit to optimise the temperature in the feed water
- Rectifier
- Process control
- Product storage tank
- Metering stations

Field of Application

- Potable water treatment
- Cooling water treatment



1.4 Electrolysis Systems CHLORINSITU and DULCOLYSE

Technical Data

Output		Number of electrolysis cells	Product volume (NaOCl)		Max. salt consumption	
kg/h	kg/d		l/h	m ³ /d	kg/h	kg/d
5	120	1	625	15	16	384
7.5	180	1	935	22.5	24	576
10	240	2	1,250	30	32	768
15	360	2	1,875	45	48	1,152
20	480	3	2,500	60	64	1,536
22.5	540	3	2,810	67.5	72	1,728
30	720	4	3,750	90	96	2,304
45	1,080	6	5,625	135	144	3,456

All figures apply for 20 °C ambient temperature and 10-20 °C feed water. The performance is affected by the temperature and quality of the water and salt.

- System availability:** 24 h/d
- Salt usage:** 3.2 kg/kg chlorine
- Energy efficiency:** 4.2 (DC) / 4.9 (AC) kWh/kg chlorine
- Product concentration:** 8 g/l (0.8 % ±0.05) chlorine
- pH value of product (approx.):** 9.5
- Salt specifications:** CHLORINSITU salt, salt tablets or salt with a grain size of ≥ 6 mm, min. 99.4 % NaCl, max. 0.05 % insoluble substances, max. 10 mg/kg iron, max. 10 mg/kg manganese, max. 100 mg/kg calcium + magnesium
- Inlet water temperature:** 10...25 °C (lower/higher temperatures require a heater/chiller)
- Water supply (drinking water quality):** 2 bar < pressure < 5 bar and flow > 50 l/min; softened water, hardness < 0.05 °dH. A system separator or interim storage tank are needed for direct connection to the water supply (refer to local regulations)
- Ambient conditions:** Non-condensing, non-corrosive and dust-free ambient air in the installation room
- Salt dissolving tank:** Customer-specific

1.4 Electrolysis Systems CHLORINSITU and DULCOLYSE

1.4.6 Electrolysis System CHLORINSITU III

Chlorine and sodium hydroxide made from common salt. Directly on-site.

Output 100 – 10,000 g/h of chlorine



Ultra-pure or low-chloride and low-chlorate sodium hypochlorite requires specialist plant engineering. The electrolysis system CHLORINSITU III is the solution for you.

Electrolysis systems of type CHLORINSITU III generate sodium hypochlorite with a concentration of approximately 25 g/l with minimal entrainment of sodium chloride (85 % yield) from the membrane cell into the finished product. The final sodium hypochlorite solution can be metered, as required, by separate metering pumps. Due to its moderate pH value of 9.5 – 10, it affects the pH of the treated water significantly less than if conventional sodium hypochlorite (pH 12 – 13.5) were used. Less acid is therefore used to adjust the pH value, enabling savings of up to 70 %.

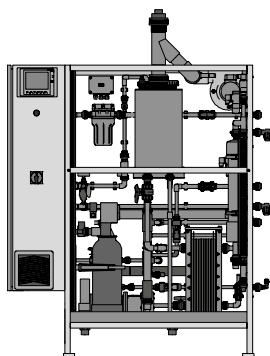

Your Benefits

- Sodium hypochlorite solution low in chloride and chlorate with a high chlorine concentration (25 g/l free chlorine)
- Minimal acid consumption for pH correction, enabling savings of up to 70 %
- Safe system control with remote diagnosis by Remote Control Engineer
- Excellent service life of the membrane cells thanks to a constant vacuum
- A frequency-controlled centrifugal pump maintains the vacuum constant in the enclosed anode area
- Excellent operating safety due to its design as a negative pressure system
- Dynamic level control in the product tank ensures optimised chlorine production
- Active process monitoring of production by largely integrated measuring and control technology
- Cost-effective operation thanks to use of inexpensive sodium chloride as a raw material
- Reduced consumption of chemicals for pH correction
- Compact, space-saving design

Technical Details

- Modern PLC with large illuminated display
- Integrated Remote Control Engineer for remote diagnosis and troubleshooting
- Storage tank for multiple points of injection

Field of Application

- Potable water
- Wastewater
- Process water
- Swimming pool water
- Cooling tower

1.4 Electrolysis Systems CHLORINSITU and DULCOLYSE

Technical Data

Power supply 3 x 400 V (VAC/3P/N/PE/50 Hz)

Type/out-put	Fuse	Power uptake	Salt consumption	Max. consumption of process water	Max. consumption of cooling water	Dimensions L x W x H	Brine tank	Recommended capacity storage tank
g/h	A	kW	kg/d	l/h	l/h		mm	l
100	3 x 16	1.10	5	4	80	1,250 x 600 x 1,550	210	200
200	3 x 16	1.50	10	8	80	1,250 x 600 x 1,550	210	300
300	3 x 16	1.90	15	12	100	1,250 x 600 x 1,550	210	400
400	3 x 16	2.30	20	16	100	1,250 x 600 x 1,550	210	500
500	3 x 16	2.70	25	20	125	1,250 x 600 x 1,550	210	600
600	3 x 20	3.10	30	24	125	1,650 x 600 x 2,000	400	700
750	3 x 25	3.70	35	30	150	1,650 x 600 x 2,000	400	800
1000	3 x 25	4.70	50	40	150	1,650 x 600 x 2,000	400	1200
1250	3 x 35	5.70	60	50	150	1,650 x 600 x 2,000	400	1500
1500	3 x 35	6.70	70	60	180	1,650 x 600 x 2,000	400	1700
1750	3 x 35	7.70	80	70	180	1,650 x 600 x 2,000	400	2000
2000	3 x 50	8.70	100	80	200	1,750 x 1,200 x 2,000	520	2200
2500	3 x 63	10.70	125	100	250	1,750 x 1,200 x 2,000	520	3000
3000	3 x 63	12.70	150	120	300	1,750 x 1,200 x 2,000	520	3300
3500	3 x 80	14.70	175	140	350	1,750 x 1,200 x 2,000	520	4000
5000	3 x 90	20.70	250	200	500	3,100 x 1,800 x 2,070	1,150	5800
7000	3 x 100	29.40	350	280	700	3,100 x 1,800 x 2,070	1,150	6000
8500	3 x 130	35.70	425	340	850	4,300 x 1,800 x 2,070	1,150	7500
10000	3 x 160	40.70	500	400	1000	4,300 x 1,800 x 2,070	1,150	11000

Scope of delivery

Electrolysis systems of type CHLORINSITU III are mounted ready-wired on a powder-coated stainless steel frame with a controller (PLC) in the control cabinet. They include a Remote Control Engineer for remote diagnosis and troubleshooting, integrated water softener system, membrane electrolysis cells, hydrogen bleed system and separate salt dissolving tanks with level monitoring unit. Dynamic level control to monitor the storage tank for sodium hypochlorite to be provided on-site. A chlorine gas detector and automatic monitoring of water hardness downstream of the softening system come as standard with systems producing more than 600 g/h.

Remark

Electrolysis systems of type CHLORINSITU II, III, V and V Plus are available and planned to meet customer specifications. This is true both for the system documentation and the subsequent supply of spare parts and maintenance.



1.4 Electrolysis Systems CHLORINSITU and DULCOLYSE

1.4.7 Electrolysis System CHLORINSITU III Compact

Chlorine produced from common salt. Directly on-site.

Output 25 – 50 g/h of chlorine



Generation of sodium hypochlorite solution for smaller swimming pools and pools.

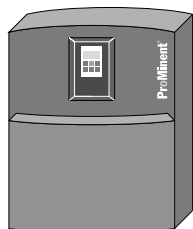

Electrolysis systems of type CHLORINSITU III Compact produce a disinfectant based on active chlorine. A saturated solution of sodium chloride is produced in a salt-dissolving tank, included in the scope of delivery, and this solution is then electrolysed in a membrane cell. The system features an integrated softener, preventing the formation of lime deposits and ensuring the long service life of the electrolysis cell. Electrolysis systems of type CHLORINSITU III Compact are especially suitable for use with smaller swimming pools in residential properties and hotels (indoor pools with a total circulation capacity of up to 40 m³/hour, chlorinated in accordance with the DIN standard).

Your Benefits

- Sodium hypochlorite solution low in chloride and chlorate with a high chlorine concentration (25 g/l free chlorine)
- Minimal acid consumption for pH correction, enabling savings of up to 70 %
- Cost-effective operation thanks to use of inexpensive sodium chloride as a raw material
- Fewer chemicals are consumed for pH adjustment
- Robust, simple technology
- Compact space-saving design, ready-mounted on a wall panel

Technical Details

- The integrated microprocessor controller digitally indicates the current output and monitors all key functions.
- All operating and error messages are shown as plain text on the clear display.
- The output can be controlled manually, automatically (controller option) or externally.
- Optional integrated chlorine and pH control

Field of Application

- Swimming pool
- Potable water
- Cooling tower

1.4 Electrolysis Systems CHLORINSITU and DULCOLYSE

Technical Data

Power supply 1 x 230 Volt (VAC/1P/N/PE/50 Hz)

Type/out-put g/h	Power uptake kW	Salt consumption g/h	Max. consumption of process water l/h	Dimensions L x W x H mm	Brine tank l
25	0.11	65	1.5	590 x 355 x 650	110
50	0.22	130	3	590 x 355 x 650	110

Scope of delivery:

Electrolysis systems of type CHLORINSITU III Compact are pre-assembled and wired for use on a wall panel. Chlorine electrolysis system with integrated microprocessor control and softener system. They include a membrane electrolysis cell, separate salt dissolving tank with level monitor and a level control for a storage tank (storage tank not included in the scope of delivery). A storage tank is also required as well as a metering pump for each point of injection (pump not included in the scope of delivery).

	Order no.
CHLORINSITU III Compact 25	1041399
CHLORINSITU III Compact 50	1041401

Spare parts and maintenance kits

		Order no.
Annual maintenance set	CHLORINSITU III Compact 25 + 50	1041407
3-yearly maintenance set	CHLORINSITU III Compact 25	1041408
3-yearly maintenance set	CHLORINSITU III Compact 50	1041410
Spare parts kit	CHLORINSITU III Compact 25/50	1045233



1.4 Electrolysis Systems CHLORINSITU and DULCOLYSE

1.4.8 Electrolysis System CHLORINSITU IV Compact

Chlorine and sodium hydroxide made from common salt. Directly on-site.

Output 25 – 50 g/h of chlorine



Produce high-purity chlorine gas in a vacuum process. Cost-effective, robust and compact.

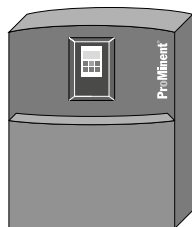

Electrolysis systems of type CHLORINSITU IV Compact generate chlorine gas in a vacuum process. A saturated solution of sodium chloride is produced in a salt-dissolving tank, included in the scope of delivery, and this solution is then electrolysed in a membrane cell. The resulting chlorine gas is suctioned off through an injector integrated in the system and dissolved as hypochlorous acid in the water being treated. The hydrogen generated is discharged to the fresh air through a bleed line. The sodium hydroxide solution is disposed of or optionally used by a metering pump integrated in the system to correct the pH of the water being treated. The salt-dissolving water comes from a softener integrated in the system, thereby preventing the formation of lime deposits and ensuring the long service life of the electrolysis cell. Electrolysis systems of type CHLORINSITU IV Compact are especially suitable for use with smaller swimming pools in residential properties and hotels (indoor pools with a total circulation capacity of up to 25 m³/hour, chlorinated in accordance with the DIN standard).

Your Benefits

- Chlorination and pH adjustment in a single system
- Production and metering of high-purity hypochlorous acid
- Cost-effective operation thanks to the use of sodium chloride as an inexpensive raw material and no consumption of chemicals for pH adjustment
- Safe negative pressure plant engineering
- Robust, simple technology

Technical Details

- The integrated microprocessor controller monitors all key functions.
- All operating and error messages are shown in plain text on the clear display.
- The output can be controlled manually, automatically or externally.

Field of Application

- Swimming pool
- Potable water
- Cooling tower

1.4 Electrolysis Systems CHLORINSITU and DULCOLYSE

Technical Data

Power supply 3 x 400 V (VAC/3P/N/PE/50 Hz)

Type/output	Power uptake	Salt consumption	Max. consumption of process water	Dimensions L x W x H	Brine tank
	g/h	kW	g/h	l/h	mm
25	0.11	65	1.5	590 x 355 x 650	110
50	0.22	130	3	590 x 355 x 650	110

Scope of delivery:

Electrolysis systems of type CHLORINSITU IV Compact are pre-assembled and wired for use on a wall panel. Chlorine electrolysis system with integrated microprocessor control and water softening system, membrane electrolysis cell with negative pressure monitoring, separate salt dissolving tank with level control, integrated injector and integrated feeder assembly for sodium hydroxide solution (optional). A booster pump is also needed (not included in the scope of delivery) for the single possible point of injection. Several pools cannot be fed from one CHLORINSITU IV Compact system.

	Order no.
CHLORINSITU IV compact 25 with pH correction	1036462
CHLORINSITU IV Compact 25	1036461
CHLORINSITU IV Compact 50 with pH correction	1036464
CHLORINSITU IV Compact 50	1036463

Spare parts and maintenance kits

Note: Both the sensors and the metering pumps have to be maintained on systems with pH and/or chlorine control.

		Order no.
Annual maintenance set	CHLORINSITU IV Compact 25	1041415
3-yearly maintenance set	CHLORINSITU IV Compact 25	1041416
Annual maintenance set	CHLORINSITU IV compact 25 with pH correction	1043267
3-yearly maintenance set	CHLORINSITU IV compact 25 with pH correction	1043268
Annual maintenance set	CHLORINSITU IV Compact 50	1041417
3-yearly maintenance set	CHLORINSITU IV Compact 50	1041418
Annual maintenance set	CHLORINSITU IV Compact 50 with pH correction	1043269
3-yearly maintenance set	CHLORINSITU IV Compact 50 with pH correction	1043270
Membrane cell	CHLORINSITU IV Compact 25	1041419
Membrane cell	CHLORINSITU IV Compact 50	1041420
Spare parts kit	CHLORINSITU IV Compact 25/50	1045232



1.4 Electrolysis Systems CHLORINSITU and DULCOLYSE

1.4.9 Electrolysis System CHLORINSITU V

Chlorine produced from common salt. Directly on-site. For clean and safe disinfection.

Output 100 – 3,500 g/h of chlorine



Electrolysis systems of type CHLORINSITU V take the place of the chlorine gas system in the swimming pool and only need salt, water and electricity to do so.

Electrolysis systems of type CHLORINSITU V generate ultra-pure chlorine gas and sodium hydroxide solution free of chloride as required and on-site. The solution is produced in a vacuum process from safe raw materials (salt and water); no dangerous chemicals have to be transported or stored, making the process particularly safe.

Function

A saturated sodium chloride solution that is electrolysed in a membrane cell is produced in a salt-dissolving tank. Ultra-pure chlorine gas and diluted residual brine are produced in the anode chamber as part of this process. The chlorine gas produced is suctioned off through an injector (vacuum system) and is fully dissolved as hypochlorous acid in the water being treated. The chlorinated water can be used to disinfect several pools via one or more controllable motor-driven ball valves. The residual brine is discarded.

The sodium hydroxide solution produced in the cathode chamber is stored temporarily and can be used for pH correction. The hydrogen produced is diluted with fresh air by a fan and discharged safely.

Your Benefits

- Chlorination and pH adjustment with a single system
- Exceedingly low chloride and chlorate content
- Production and metering of high-purity hypochlorous acid without temporary storage
- Hypochlorite booster for peaks in demand (Plus system)
- Safe system control with remote diagnosis by Remote Control Engineer
- Excellent service life of the membrane cells thanks to a constant vacuum
- Excellent operating safety due to its design as a negative pressure system
- Active process control of production by largely integrated measuring and control technology
- Cost-effective operation thanks to the use of sodium chloride as an inexpensive raw material and no consumption of chemicals for pH adjustment
- Complete disposal of the diluted brine, nothing is fed back into the process water being treated
- Chloride/chlorate content in the process water comparable with pure chlorine gas

Technical Details

- Modern PLC with large display
- Integrated Remote Control Engineer for remote diagnosis and troubleshooting
- Chlorine metering and pH value correction controlled via contact inputs
- Analogue input (optional)
- Modbus or PROFIBUS® (optional)
- Several points of injection (optional)
- Multiple booster pumps (optional) can be used for different water qualities (e.g. brine and freshwater pools)

Field of Application

- Potable water
- Process water
- Swimming pool water
- Cooling tower

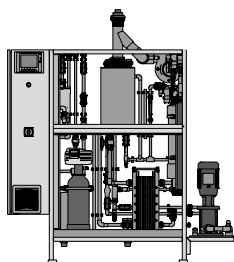

1.4 Electrolysis Systems CHLORINSITU and DULCOLYSE

Technical Data

Power supply 3 x 400 V (VAC/3P/N/PE/50 Hz)

Type/output	Fuse	Power uptake	Salt consumption	Max. consumption of process water	Consumption of cooling water (external)	Dimensions L x W x H	Brine tank
g/h	A	kW	kg/d	l/h	l/h	mm	l
100	3 x 16	1.10	5	60	-	1,655 x 600 x 1,550	210
200	3 x 16	1.50	10	60	-	1,655 x 600 x 1,550	210
300	3 x 16	1.90	15	60	-	1,655 x 600 x 1,550	210
400	3 x 16	2.30	20	60	-	1,655 x 600 x 1,550	210
500	3 x 16	2.70	25	60	-	1,655 x 600 x 1,550	210
600	3 x 20	3.10	30	90	-	1,950 x 600 x 2,000	400
750	3 x 25	3.70	35	90	-	1,950 x 600 x 2,000	400
1000	3 x 25	4.70	50	90	-	1,950 x 600 x 2,000	400
1250	3 x 35	5.70	60	90	-	1,950 x 600 x 2,000	400
1500	3 x 35	6.70	70	90	-	1,950 x 600 x 2,000	400
1750	3 x 35	7.70	80	90	-	1,950 x 600 x 2,000	400
2000	3 x 50	8.70	100	175	200	1,750 x 1,200 x 2,000	520
2500	3 x 80	14.70	175	175	250	1,750 x 1,200 x 2,000	520
3000	3 x 63	10.70	150	175	300	1,750 x 1,200 x 2,000	520
3500	3 x 63	12.70	175	175	350	1,750 x 1,200 x 2,000	520

Capacities > 3,500 g/h upon request

Scope of delivery:

Electrolysis systems of type CHLORINSITU V are ready mounted, wired for use, on a powder coated stainless steel frame with a Programmable Logic Controller (PLC) in the control cabinet, Remote Control Engineer for remote diagnosis and troubleshooting, integrated water softening unit, membrane electrolysis cells, hydrogen bleed system and separate salt dissolving tank with level monitoring. The scope of delivery also includes a frequency-controlled central injector system matched to the system to meter active chlorine and sodium hydroxide solution for pH correction and a single booster pump. A chlorine gas warning unit and automatic monitoring of water hardness downstream of the softening system come as standard with systems producing more than 600 g/h.

Remark

Electrolysis systems of type CHLORINSITU II, III, V and V Plus are available and planned to meet customer specifications. This is true both for the system documentation and the subsequent supply of spare parts and maintenance.



1.4 Electrolysis Systems CHLORINSITU and DULCOLYSE

1.4.10 Electrolysis System CHLORINSITU V Plus

Chlorine produced from common salt. Directly on-site. For clean and safe disinfection.

Output 100 – 3,500 g/h of chlorine



Electrolysis systems of type CHLORINSITU V take the place of the chlorine gas system in the swimming pool and only need salt, water and electricity to do so.

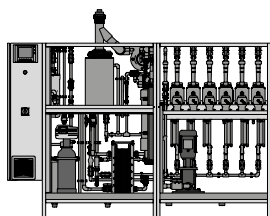

Electrolysis systems of type CHLORINSITU V Plus generate ultra-pure chlorine gas and sodium hydroxide solution free of chloride as required and on-site. The disinfection solution is produced in a vacuum process from safe raw materials (salt and water); no dangerous chemicals have to be transported or stored, making the process particularly safe.

The ultra-pure disinfection solution contains only minimal quantities of chloride and chlorate - yet is highly effective and safe.

Function with an added extra

A saturated sodium chloride solution that is electrolysed in a membrane cell is produced in a salt-dissolving tank. Ultra-pure chlorine gas and diluted residual brine are produced in the anode chamber as part of this process. The chlorine gas produced is suctioned off through an injector (vacuum system) and is fully dissolved as hypochlorous acid in the water being treated. The chlorinated water can be used to disinfect several pools via one or more controllable motor-driven ball valves. The residual brine is discarded.

The Plus system

What makes the CHLORINSITU V Plus electrolysis systems so special is that surplus chlorine gas is combined with the sodium hydroxide solution produced and then temporarily stored as sodium hypochlorite (Plus system). Peaks in demand are covered by the additional dosing of sodium hypochlorite from the temporary storage. As a result, the system does not have to be designed for the maximum chlorine gas demand but rather on the basis of average daily demand. This allows our customers to respond quickly and flexibly should demand rise sharply at certain times.

Metering takes place via a central injector system, as with hypochlorous acid. What's more the chloride-free sodium hydroxide solution can be stored temporarily and used for pH correction.

Your Benefits

- Chlorination and pH adjustment with a single system
- Exceedingly low chloride and chlorate content
- Production and metering of high-purity hypochlorous acid without temporary storage
- Hypochlorite booster for peaks in demand (Plus system)
- Safe system control with remote diagnosis by Remote Control Engineer
- Excellent service life of the membrane cells thanks to a constant vacuum
- Excellent operating safety due to its design as a negative pressure system
- Active process control of production by largely integrated measuring and control technology
- Cost-effective operation thanks to the use of sodium chloride as an inexpensive raw material and no consumption of chemicals for pH adjustment
- Complete disposal of the diluted brine, nothing is fed back into the process water being treated
- Chloride/chlorate content in the process water comparable with pure chlorine gas

Technical Details

- Modern PLC with large display
- Integrated Remote Control Engineer for remote diagnosis and troubleshooting
- Chlorine metering and pH value correction controlled via contact inputs
- Analogue input (optional)
- Modbus or PROFIBUS® (optional)
- Several points of injection (optional)
- Multiple booster pumps (optional) can be used for different water qualities (e.g. brine and freshwater pools)

Field of Application

- Potable water
- Process water
- Swimming pool water
- Cooling tower



1.4 Electrolysis Systems CHLORINSITU and DULCOLYSE

Technical Data

Power supply 3 x 400 V (VAC/3P/N/PE/50 Hz)

Type/output	Fuse	Power uptake	Salt consumption	Max. consumption of process water*	Consumption of cooling water (external)	Dimensions L x W x H	Brine tank	Recommended capacity storage tank
g/h	A	kW	kg/d	l/h	l/h	mm	l	l
100	3 x 16	1.10	5	60	-	1,655 x 600 x 1,550	210	50
200	3 x 16	1.50	10	60	-	1,655 x 600 x 1,550	210	100
300	3 x 16	1.90	15	60	-	1,655 x 600 x 1,550	210	150
400	3 x 16	2.30	20	60	-	1,655 x 600 x 1,550	210	200
500	3 x 16	2.70	25	60	-	1,655 x 600 x 2,000	210	250
600	3 x 20	3.10	30	90	-	1,950 x 600 x 2,000	400	300
750	3 x 25	3.70	40	90	-	1,950 x 600 x 2,000	400	400
1000	3 x 25	4.70	55	90	-	1,950 x 600 x 2,000	400	500
1250	3 x 35	5.70	60	90	-	1,950 x 600 x 2,000	400	600
1500	3 x 35	6.70	75	90	-	1,950 x 600 x 2,000	400	750
1750	3 x 35	7.70	85	90	-	1,950 x 600 x 2,000	400	850
2000	3 x 50	8.70	100	175	200	1,750 x 1,200 x 2,000	520	1000
2500	3 x 63	10.70	125	175	250	1,750 x 1,200 x 2,000	520	1250
3000	3 x 63	12.70	150	175	300	1,750 x 1,200 x 2,000	520	1500
3500	3 x 80	14.70	175	175	350	1,750 x 1,200 x 2,000	520	1750

* The consumption of process water depends on the ratio of chlorine gas to stock production. The value is given here for a ratio of 70% : 30 %.

Capacities > 3,500 g/h upon request

Scope of delivery:

Electrolysis systems of type CHLORINSITU V Plus are ready mounted, wired for use, on a powder-coated stainless steel frame with a Programmable Logic Controller (PLC) in the control cabinet, Remote Control Engineer for remote diagnosis and troubleshooting, integrated water softening unit, membrane electrolysis cells, hydrogen bleed system and separate salt dissolving tank with level monitoring. The scope of delivery also includes a frequency-controlled central injector system matched to the system to meter active chlorine and sodium hydroxide solution for pH correction and a single booster pump. A level control to monitor the storage tank for sodium hypochlorite to be provided on-site. A chlorine gas detector and automatic monitoring of water hardness downstream of the softening system come as standard with systems producing more than 600 g/h.

Remark

Electrolysis systems of type CHLORINSITU II, III, V and V Plus are available and planned to meet customer specifications. This is true both for the system documentation and the subsequent supply of spare parts and maintenance.

1.4 Electrolysis Systems CHLORINSITU and DULCOLYSE

1.4.11 Questionnaire on the Design of a DULCOLYSE Electrolysis System

Application

- Bottler flushing
- CIP
- Other _____

Application details

Number of bottlers: _____

Flushing duration: _____

Required volume to be added to bottler: _____ Recommendation with material SS 316 L 2-4 ppm

Number of CIP points of injection: _____

Duration of CIP: _____

Required volume to be added for CIP: _____ Recommendation 10-15 ppm

Water data:

Max. volume of water to be treated	_____ m ³ /h	maximum water pressure	_____ bar
Water flow	<input type="checkbox"/> constant	<input type="checkbox"/> fluctuating from	_____ m ³ /h to _____ m ³ /h
pH value	_____	(iron (Fe ²⁺	_____ mg/l)
Temperature	_____ °C	(manganese (Mn ²⁺	_____ mg/l)
Proportion of solids	_____ mg/l	(nitrite (NO ₂ ⁻	_____ mg/l)
Acid capacity K _{S4,3}	_____ mmol/l	(sulphide (S ²⁻	_____ mg/l)
Total hardness	_____ mmol/l	(Total Organic Carbon	_____ mg/l)
Total hardness	_____ °dH	(ammonium	_____ mg/l)

Reaction time to application

_____ m³ volume of reaction tank or _____ minutes dwell time in the total system.

Disinfection method used to date:

Disinfectant consumed to date: _____ kg/week

Other requirements:





1.4 Electrolysis Systems CHLORINSITU and DULCOLYSE

1.4.12 Electrolysis System DULCOLYSE

Innovative disinfection. The benefits for you: Minimum chlorate and chloride content.

Output: up to 800 g/h



Efficient production of the highly effective disinfectant DULCOLYLT 400 with an exceptionally low chloride and chlorate content. Ideal for particularly sensitive applications in the beverage and food industry, e.g. for the production of baby food. Maximum protection against corrosion and very good cost efficiency.



Excessive concentrations of chlorate in beverages and foodstuffs are harmful to human health and strictly regulated. They can be avoided in their entirety with ProMinent's DULCOLYSE system. The disinfectant produced on-site ensures not just the lowest possible chlorate and chloride values, it is also a cost-effective alternative to conventional chemicals.

The system produces the highly effective disinfectant DULCOLYLT 400, which delivers less than 0.01 ppm of chlorate for one 1 ppm of FAC (Free Available Chlorine). This is a considerably lower chlorate content than with conventional processes and is well below the target limit values.

Even the chloride by-product occurs in a much lower concentration than with conventional technologies, thereby preventing corrosion. The process ensures environmentally-friendly, highly effective disinfection and long-term freedom from germs without the need to transport, store and handle highly concentrated chemicals.

Your Benefits

- Ultra-low chlorate content for disinfection with minimal by-products
- Extremely low chloride content for maximum protection and freedom from corrosion within the plant
- Environmentally friendly, highly effective disinfection
- Long-term freedom from germs, without any transport, storage or handling of highly concentrated chemicals
- Handling of chemicals is reduced (only sodium chloride is required)
- Compact, space-saving design

Technical Details

- Modern PLC with large display
- Integrated Remote Control Engineer for remote diagnosis and troubleshooting
- Supplied ready for connection in stainless steel housing
- Duplex softening system
- Salt-dissolving tank with level monitoring

Field of Application

- Food industry
- Beverage industry

1.4 Electrolysis Systems CHLORINSITU and DULCOLYSE

Technical Data

Power supply: 1 x 230 Volt (V AC/1P/N/PE/50 Hz)

Dimensions (H x W x D): 2,100 x 1,250 x 610 mm

Type/out-put	DULCOLYLT production at 400 ppm	Power uptake	Salt solution tank volume	Cabinet	Order no.
g/h	l/h	kW	l		
DULCOLYSE 100	100	250	1.10	210 stainless steel	1041424
DULCOLYSE 100	100	250	1.10	210 open cabinet	1062093
DULCOLYSE 200	200	500	1.50	210 stainless steel	1043987
DULCOLYSE 200	200	500	1.50	210 open cabinet	1062104
DULCOLYSE 300	300	750	1.90	210 stainless steel	1043988
DULCOLYSE 300	300	750	1.90	210 open cabinet	1062135

NEW

DULCOLYSE on request with enhanced capacities of up to 800 g/h; only as open cabinet design.

Scope of delivery:

DULCOLYSE electrolysis systems are fitted ready for use in a sealed stainless steel or open cabinet

- PLC (Programmable Logic Controller) in the attached control cabinet
- Duplex water softening system
- Salt-dissolving tank with level monitoring
- Ultrasound level probe for the DULCOLYLT product tank
- Piping between the salt-dissolving storage tank and DULCOLYSE system
- Hardness control measuring equipment
- pH4 + pH7 buffer solution

Not included in the scope of delivery:

- DULCOLYLT product tank
- DULCOLYLT metering station

Spare parts and maintenance kits

	Type	Order no.
Spare parts kit up to manufacturing year 2015	DULCOLYSE 100 – 300	1044366
Spare parts kit from manufacturing year 2015 onwards	DULCOLYSE 100 – 300	1079469
Annual maintenance set	DULCOLYSE 100 – 300	1041427
3-yearly maintenance set	DULCOLYSE 100 – 300	1041430





1.4 Electrolysis Systems CHLORINSITU and DULCOLYSE

1.4.13 Accessories

Water hardness measuring kit

For manual determination of the overall hardness

	Order no.
Water hardness measuring kit for overall hardness	505505

Spare cells DULCOLYSE

	Capacity	Order no.
HMC 10-1	100	1041433
HMC 10-2	200	1074133
HMC 10-3	300	1074134

Metering systems DULCODOS DSKa for connection to DULCOLYSE product tanks

Metering system DULCODOS DSKa for connection to DULCOLYSE product tank, for motor-driven metering pump Sigma, electrically and mechanically ready mounted on a PP frame. Scope of delivery:

- Diaphragm damper
- Back pressure valve
- Relief valve including manometer
- Flushing connector for suction and discharge side
- Repair switch
- Select the metering pump separately, see Metering pumps table

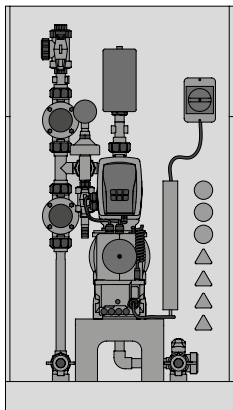

	Feed rate at max. pressure	Order no.
Metering system for sigma/ X S1Cb	53/101/117	1083511
Metering system for sigma/ X S2Cb	150/271/353	1077030
Metering system for sigma/ X S3Cb	500/670	1077109
Metering system for sigma/ X S3Cb	670 – 1040	1083512

Recommended metering pumps for metering systems DULCODOS DSKa:

Pump type	Identity code
sigma/ X S2Cb	S2CBH 07220 PVTS 010 U 1110S0 EN
sigma/ X S2Cb	S2CBH 04350 PVTS 010 U 1110S0 EN
sigma/ X S3Cb	S3CBH 070580 PVTS 110 U 1110S0 EN

DULCOLYSE product tanks for connection to the metering system DULCODOS DSKa

Capacity	Order no.
500	1076956
1,000	1076957

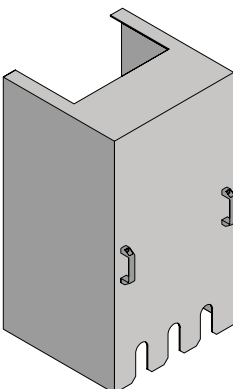

Accessories for metering systems DULCODOS DSKa

	Order no.
Spray guard hood for DULCODOS DSKa	1042751
Spray guard hood for DULCODOS DSKa for PP bracket without terminal box	1040456

2.1 Polymer Preparation and Metering Systems

2.1.1 Polyelectrolytes in Water Treatment

The use of polyelectrolytes as flocculation aids is characterised by an extensive field of applications. They can be used in all applications where colloidal solids need to be economically separated from liquids.

Our preparation and metering systems have been designed specifically for the production of ordinary or standard solutions of synthetic polyelectrolytes in powdered or liquid form and have proved themselves many times over.

The experts in wastewater treatment at ProMinent understand how to provide the efficient technology to implement this specialist application. They have developed systems for the most stringent requirements, which are also very easy to assemble and operate.

ProMinent also provides all the advice needed for the efficient operation of a polymer batching and metering system:

- Evaluation of the situation on-site by trained, expert field sales staff.
- Project planning of the system.
- Commissioning and system maintenance by our trained service technicians.

2.1 Polymer Preparation and Metering Systems

2.1.2 Performance Overview of Polymer Preparation and Metering Systems ULTROMAT, DULCODOS and PolyRex

ProMinent offers a wide range of systems for the most diverse preparation and metering applications. The following overview shows the capacity ranges of our type series:

Continuous flow system			
	Extraction rate l/h concentration max. 0.5 %	Application	Characteristic
ULFa <ul style="list-style-type: none"> • Powder • Liquid 	400 – 8,000 (maturation time 60 min., starts with batching mode)	<ul style="list-style-type: none"> • Potable water treatment • Wastewater treatment (industry and local authorities) • Sludge dewatering 	<ul style="list-style-type: none"> • Simple screw feeder with good dosing precision proportional to the water supply • Functionally simple mixing system with/without wetting cone • PP tank, 3-chamber design
Batch preparation stations			
	Extraction rate l/h Concentration max. 0.5 %	Application	Characteristic
ULDa <ul style="list-style-type: none"> • Powder • Liquid 	400 – 2000 (maturation time 60 min., starts with preparation mode)	<ul style="list-style-type: none"> • Potable water treatment • Waste water treatment (industrial and local authorities) • Sludge dewatering 	<ul style="list-style-type: none"> • Simple screw feeder with good dosing precision proportional to the water supply • Functionally simple mixing system with/without wetting cone • PP tank, double-decker design
PolyRex <ul style="list-style-type: none"> • Powder • Liquid 	240 – 8200 (maturation time 45 min., starts after metering)	<ul style="list-style-type: none"> • Potable water treatment • Waste water treatment (industrial and local authorities) • Sludge dewatering • Paper production 	<ul style="list-style-type: none"> • Multi-screw feeder with high dosing precision • Special flushing system with water ejector for effective powder hydration • Stainless steel tanks, double-decker design • Integrated Big Bag emptying system
PolyRex Liquid <ul style="list-style-type: none"> • Liquid 	1060 – 3180 (maturation time 15 min., starts after metering)	<ul style="list-style-type: none"> • Waste water treatment (industrial and local authorities) • Sludge dewatering 	<ul style="list-style-type: none"> • High-energy mixing • Stainless steel tanks
MT <ul style="list-style-type: none"> • Powder 	140 – 4000	<ul style="list-style-type: none"> • Potable water treatment • Waste water treatment (industrial and local authorities) • Sludge dewatering 	<ul style="list-style-type: none"> • For manual preparation mode • Ultra-simple mixing system • PP tank
In-line preparation station			
	Extraction rate l/h Concentration max. 1.0 %	Application	Characteristic
ULIa <ul style="list-style-type: none"> • Liquid 	55 – 400 (maturation time 15 min, starts with preparation mode)	<ul style="list-style-type: none"> • Sludge dewatering and thickening • Drinking water treatment • Wastewater treatment (industry and local authorities) 	<ul style="list-style-type: none"> • Integrated mixing and maturing chamber for fully activated liquid polymer solutions • Peristaltic pump and/or metering pumps for the metering of emulsions/dispersions • Operator-managed input of the concentration with proportional metering • Optional specification of the polymer preparation output
Pendulum system			
	Extraction rate l/h concentration max. 0.5 %	Application	Characteristic
ULPa <ul style="list-style-type: none"> • Powder • Liquid 	400 – 4,000 (maturation time 60 min., starts with batching mode)	<ul style="list-style-type: none"> • Potable water treatment • Paper production 	<ul style="list-style-type: none"> • Simple screw feeder with good dosing precision proportional to the water supply • Functionally simple mixing system with wetting cone • Preparation system using 2 PP tanks



2.1 Polymer Preparation and Metering Systems

2.1.3 Questionnaire for the Design of Polymer Preparation and Metering Systems ULTROMAT, DULCODOS and PolyRex

2

For the treatment of

- Potable water
- Wastewater
- Sludge
- Paper
- _____

Polymer available as

- Powdered polymer
- Liquid polymer
- Active substance: _____

Required quantities

- Concentration of the batched solution: _____
- Max. metering quantity (volume of polymer): _____
- Required maturing time: _____

Quality of dilution water

- Potable water
- Industrial water

Mains voltage supply

- 400 V AC/50/60 Hz
- 440 – 480 VAC/60 Hz
- Other: _____

Other requirements



2.1 Polymer Preparation and Metering Systems

2.1.4 Preparation Stations and Metering of Powdered and Liquid Polymer Solutions ULTROMAT and DULCODOS

Preferred fields of application include:

- Drinking water treatment
- Wastewater treatment (industry and local authorities)
- Sludge dewatering
- Paper production

4 different system concepts are available:

- Continuous flow system (identity code ULFa)
- Pendulum system (identity code ULPa)
- Double-decker system (identity code ULDa)
- Inline preparation station (identity code ULla)

The systems differ primarily in terms of the construction of the tank. The tank in the continuous flow system is subdivided into 3 chambers, largely preventing the mixing of fresh and matured polymer. Pendulum and double-deck systems are designed with two completely separate tanks. This prohibits the mixing of fresh and matured polymer. An integrated mixing and maturing chamber is used with the inline preparation station.

Powder feeder units and liquid concentrate pumps can be freely selected by means of the identity code. Powdered or liquid polymers can therefore be prepared depending on the application.

ULTROMAT and DULCODOS device types ULFa, ULPa, ULDa and ULla are equipped with a PLC compact controller and touch panel. As an option, the PLC compact controller can be fitted with a PROFIBUS®, Modbus or PROFINET module. The user manages input of the solution concentration as well as calibration of the powder feeder unit and liquid concentrate pump. Alarm messages and warnings are shown on the display. The feed of dilution water is continuously recorded by a flow meter and displayed on the touch panel. The control calculates the polymer requirement based on the set solution concentration and proportionately controls the powder feeder unit or concentrate pump so that the concentration of polymer solution is always kept constant even if there are fluctuations in the water supply.

Application example for a ULFa polymer preparation system

- Big Bag handling
- Powder conveyor
- Powder storage vessel
- ULTROMAT ULFa
- Chemical transfer pump
- Post-dilution

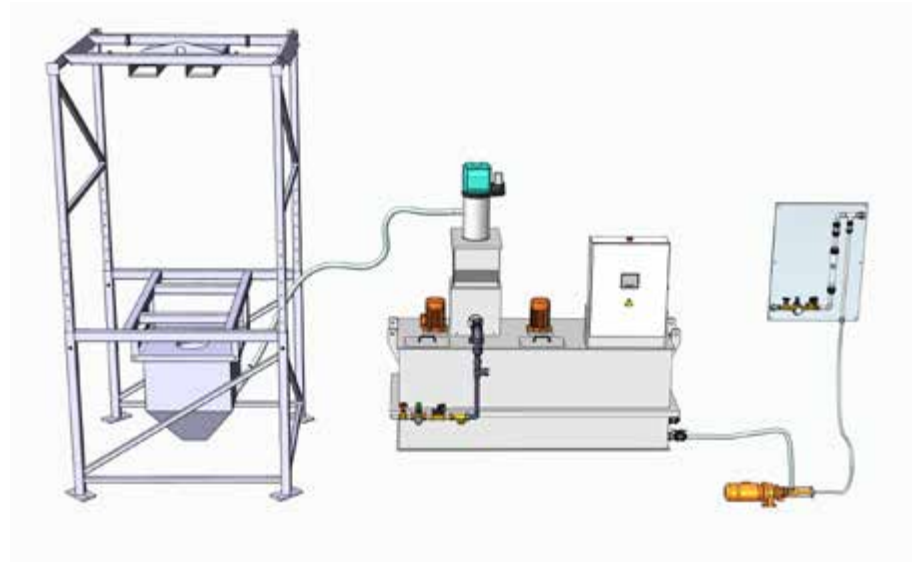

2.1 Polymer Preparation and Metering Systems

2.1.5 Metering System ULTROMAT ULFa

Efficient production of a polymer solution with a high throughput capacity.

Extraction rates of up to 8,000 l/h



Polymer preparation station ULTROMAT ULFa (continuous flow system): This metering system can be used to batch flocculation aids for the preparation of a ready-to-use polymer solution. The system was designed for the fully automatic batching of polymer solutions.

These systems can be used to handle both liquid and powdered polymers. The tank, which is sub-divided into three chambers, largely prevents the entrainment of the freshly prepared polymer.

Your Benefits

- Processing of powdered polymers (0.05 – 0.5 %) and liquid polymers (0.05 – 1.0 %)
- Minimal carry-over of product and thus high-quality results
- Operator-controlled input of solvent concentration and calibration of powder feeder unit and liquid concentrate pump
- Gentle mixing of the polymer solution using electric stirrers, running as standard at approx. 700/840 rpm, available as an option with gearbox stirrer in the first preparation chamber running at approx. 70/84 rpm (relative to 50/60 Hz mains supplies)
- New: information about consumption of the liquid polymer via 4-20 mA signal of liquid concentrate pump DFXa
- Pressure sensor for measuring the liquid level
- Version with terminal box available on request

Technical Details

Siemens S7 – 1200 compact control system and KTP 400 touch panel

- Optionally fitted with PROFIBUS® and DP/DP coupler
- Optionally fitted with PROFINET and PN/PN coupler
- Optionally fitted with Modbus TCP
- Optional post dilution units for usage solutions of 1,000 - 50,000 l/h, inductive flow meter (opt.)

Field of Application

- Potable water treatment
- Wastewater treatment (industry and local authorities)
- Sludge de-watering

The following types of polymer can be processed:

- Powdered polymers (0.05 - 0.5%)
- Liquid polymers (0.05 - 1.0 %) with a 50 % active ingredient

Selectable components:

- Tank size/extraction rate
- Construction (normal or mirror image)
- Wide-range power connection for 50 Hz or 60 Hz mains supplies
- Control S7 – 1200 (with and without PROFIBUS®/PROFINET/Modbus TCP)
- Powder feeder unit and various types of add-on hoppers for powder storage
- Vibrator for powder feeder unit and various types of add-on hoppers for powder storage (promotes the movement of polymer)
- Powder conveyor FG205 (for automatically filling the powder feeder unit)
- Liquid concentrate pumps of types sigma, SPECTRA, DULCOFLEX and DULCOFLEX DFXa
- Monitor for liquid concentrate pump (float switch/flow monitor)
- Flush valve (Y-flush inlet or wetting cone)
- Gearbox driven stirrer in preparation chamber 1
- Stirrer for 3rd chamber
- Language (pre-set language for the touch panel)
- Gearbox driven stirrer in preparation chamber 1

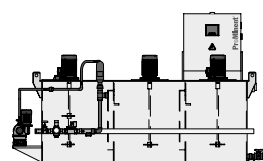

ULTROMAT ULFa for liquid polymers

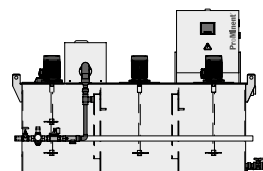

ULTROMAT ULFa for powder polymers

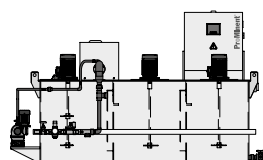

ULTROMAT ULFa for powder and liquid polymers

2.1 Polymer Preparation and Metering Systems

The standard scope of delivery includes among other things:

- Pause function/operating message/running dry function
- Preparation operation active message
- Monitoring of an optional post dilution unit
- Lifting lugs for transport

2.1 Polymer Preparation and Metering Systems

Technical Data

		400	1,000	2,000	4,000	6,000	8,000
Discharge volume	l/h	400	1,000	2,000	4,000	6,000	8,000
Useful tank volume (with reserve of approx.10%)	l	400	1,000	2,000	4,000	6,000	8,000
Raw water feed	l/h	600	1,500	3,000	6,000	9,000	12,000
Water pressure	bar	3...5	3...5	3...5	3...5	3...5	3...5
Max. dosing rate of powdered polymer	kg/h	11	11	18	55	55	110
Max. dosing rate of liquid polymer (with 50% active ingredient)	l/h	12	30	60	120	180	240
Length	mm	1,999	2,643	3,292	3,301	4,120	4,605
Width	mm	918	1,002	1,186	1,456	1,651	1,910
Height	mm	1,390	1,740	1,890	2,182	2,182	2,290
Water connection for raw water	Inch	1	1	1	1 1/2	1 1/2	2
Discharge nozzle DN	mm	25	25	32	40	40	50
Concentrate feed DN	mm	15	15	15	20	20	20
Nominal voltage/frequency	V AC/Hz	400/50 460/60	400/50 460/60	400/50 460/60	400/50 460/60	400/50 460/60	400/50 460/60
Power uptake	kW	1.5	2.6	3.2	5.0	5.0	9.5
Enclosure rating		IP 55 *	IP 55 *	IP 55 *	IP 55 *	IP 55 *	IP 55 *

* IP54 at 460 V AC



2.1 Polymer Preparation and Metering Systems

Identity Code Ordering System for ULTROMAT ULFa (Continuous Flow Systems)

ULFa	Type / Tank size / Discharge volume
0400	Continuous flow system / 400 l / 400 l/h
1000	Continuous flow system / 1000 l / 1000 l/h
2000	Continuous flow system / 2000 l / 2000 l/h
4000	Continuous flow system / 4000 l / 4000 l/h
6000	Continuous flow system / 6000 l / 6000 l/h
8000	Continuous flow system / 8000 l / 8000 l/h
Design	
1	Stirrer propeller in PP / Innomotics motors / ULFa 0400-2000
2	Stirrer propeller in stainless steel 1. Stirrer and PP / Innomotics motors / ULFa 4000-8000
3	Stirrer propeller in stainless steel / Innomotics motors / ULFa 0400-8000
4	Stirrer propeller in PP / LHP motors / ULFa 0400-2000
5	Stirrer propeller in stainless steel - 1. Stirrer and PP / LHP motors / ULFa 4000-8000
6	Stirrer propeller in stainless steel / LHP motors / ULFa 0400-8000
G	Gear box driven stirrer in preparation chamber 1
Electrical Connection	
A	380-420 VAC, 50 Hz (3-phase, N, PE)
B	440-480 VAC, 60 Hz (3-phase, N, PE)
Control	
0	PLC S7-1200
1	PLC S7-1200 with PROFIBUS® (DP/DP coupler)
2	PLC Programmable Logic Controller S7-1200 with PROFINET (PN/PN coupler)
3	PLC Programmable Logic Controller S7 – 1200 with MODBUS TCP
4	With terminal box (without control cabinet)
5	PLC+HMI Schneider TM 241
6	PLC+HMI Schneider TM 241 with Profibus (DP/DP coupler)
7	PLC+HMI Schneider TM 241 with Profinet (PN/PN coupler)
8	PLC+HMI Schneider TM 241 with Modbus TCP
Options	
0	None
1	Discharge pipework, PVC (400, 1000)
2	Discharge pipework, PVC (2000)
3	Discharge pipework, PVC (4000, 6000)
4	Discharge pipework, PVC (8000)
Powder feeder	
P0	None
P1	Powder feeder (0400, 1000)
P2	Powder feeder (2000)
P3	Powder feeder (4000, 6000)
P4	Powder feeder (8000)
Vibrator for powder feeder	
0	None
1	With vibrator for powder feeder
Powder conveyor FG 205, add-on hopper	
0	None
1	With add-on hopper 50 l (0400, 1000, 2000)
2	With add-on hopper 75 l (4000, 6000)
3	With add-on hopper 100 l (8000)
4	With add-on hopper 50 l + powder conveyor unit FG205 (0400, 1000, 2000)
5	With add-on hopper 75 l + powder conveyor unit FG205 (4000, 6000)
6	With add-on hopper 100 l + powder conveyor unit FG205 (8000)
7	With adapter cover + powder conveyor unit FG205
A	With add-on hopper 50 l + visual level indicator (0400, 1000, 2000)
B	With add-on hopper 75 l + visual level indicator (4000/6000)
C	With add-on hopper 100 l + visual level indicator (8000)
Liquid concentrate pump	
L0	None
L1	With DFXa (0400-2000) or Sigma (4000-8000) fitted
L2	With SPECTRA fitted (0400-8000)
L3	Prepared for DFXa/sigma 4-20 mA control
L4	Prepared for SPECTRA FC control
L5	Prepared for DFXa/sigma 4-20 mA control, no bracket
L6	Prepared for SPECTRA FC control, no bracket
L7	Prepared for DFBa peristaltic pump FC control (4000-8000)
L8	With DFBa peristaltic pump fitted (4000-8000)
Monitoring for liquid concentrate pump	
0	None
1	With capacitive sensor for concentrate tank
2	With flow monitor, only SPECTRA
3	With capacitive sensor and flow monitor, only SPECTRA
Water pipework with wetting fitting	
1	Y-wetting fitting, PVC (0400, 1000, 2000)
2	Y-wetting fitting, PVC (4000, 6000)
3	Y-wetting fitting, PVC (8000)
4	Wetting cone, PVC (0400, 1000, 2000)

2.1 Polymer Preparation and Metering Systems

5	Wetting cone, PVC (4000, 6000)
6	Wetting cone, PVC (8000)
7	Wetting cone, PP (0400, 1000, 2000)
8	Wetting cone, PP (4000, 6000)
9	Wetting cone, PP (8000)
Stirrer for 3 rd chamber	
0	None
1	Stirrer for storage tank 400, 0.18/0.25 kW, 50/60 Hz
2	Stirrer for storage tank 1000, 0.55/0.68 kW, 50/60 Hz
3	Stirrer for storage tank 2000, 0.75/0.86 kW, 50/60 Hz
4	Stirrer for storage tank 4000/6000, 1.1/1.3 kW, 50/60 Hz
5	Stirrer for storage tank 8000, 2.2/2.55 kW, 50/60 Hz
Language	
	BG Bulgarian
	CN Chinese
	CZ Czech
	DA Danish
	DE German
	EL Greek
	EN English
	ES Spanish
	ET Estonian
	FI Finnish
	FR French
	HR Croatian
	HU Hungarian
	IT Italian
	LT Lithuanian
	LV Latvian
	MS Malay
	NL Dutch
	NO Norwegian
	PL Polish
	PT Portuguese
	RO Romanian
	RU Russian
	SK Slovakian
	SL Slovenian
	SV Swedish
	TR Turkish





2.1 Polymer Preparation and Metering Systems

2.1.6 Metering System ULTROMAT ULPa

A good solution when preparing polymer solutions as flocculation aids.

Extraction rates from 400 to 4,000 l/h



The metering system ULTROMAT ULPa (oscillating system) is ideal for batching flocculation aids for the preparation of a ready-to-use polymer solution.

ULTROMAT ULPa consists of two separate chambers which are successively filled with polymer solution, thereby ruling out the risk of product carry-over. Both liquid and powdered polymers can be processed depending on the product range.

Your Benefits

- Processing of liquid polymers (0.05 - 1.0 %) and powdered polymers (0.05 - 0.5 %)
- No mixing of fresh and matured polymer
- Operator-controlled input of solvent concentration and calibration of powder feeder and liquid concentrate pump
- Gentle mixing of the polymer solution (electric stirrer)
- Pressure sensor for the measurement of the liquid level
- Version with terminal box available on request

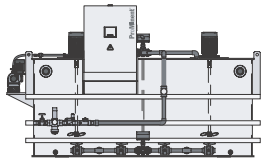

ULTROMAT ULPa for liquid polymers

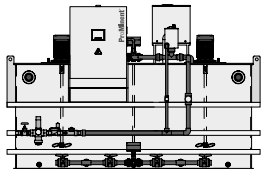

ULTROMAT ULPa for powder polymers

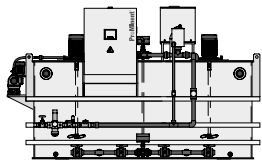

ULTROMAT ULPa for powder and liquid polymers

Technical Details

Siemens S7 – 1200 compact control system and KTP 400 touch panel

- Optionally fitted with PROFIBUS® and DP/DP coupler
- Optionally fitted with PROFINET and PN/PN coupler
- Optionally fitted with Modbus TCP

Field of Application

- Potable water treatment
- Paper production

The following types of polymer can be processed:

- Liquid polymers (0.05 – 1.0 %)
- Powdered polymers (0.05 – 0.5%)

Selectable components:

- Tank size / extraction rate
- Construction (normal or mirror image)
- Electrical connection
- Control S7 – 1200 (with and without PROFIBUS®/PROFINET/Modbus TCP)
- Powder feeder unit
- Vibrator for powder feeder unit (promotes the movement of polymer)
- Powder conveyor FG205/add-on hopper (for filling and feeding the powder feeder unit)
- Liquid concentrate pumps of types sigma, SPECTRA, DULCOFLEX DFXa
- Monitor for liquid concentrate pump (float switch/flow monitor)
- Flush valve
- Language (pre-set language for the control panel)

The standard scope of delivery includes among other things:

- Pause function/operating message/running dry function
- Monitoring of the post dilution unit
- Lifting lugs for transport

2.1 Polymer Preparation and Metering Systems

Technical Data

Discharge volume	l/h	400	1,000	2,000	4,000
Tank contents	l	2 x 400	2 x 1,000	2 x 2,000	2 x 4,000
Raw water feed	l/h	1,600	4,000	8,000	16,000
Water pressure	bar	3...5	3...5	3...5	3...5
Powdered polymer	kg/h	0.5...11	0.8...18	3.6...55	4.8...110
Length	mm	2,040	2,840	3,340	4,540
Width	mm	1,253	1,733	1,918	2,583
Height	mm	1,635	1,739	2,178	2,384
Water connection for raw water	Inch	1	1 1/4	1 1/2	2
Discharge nozzle DN	mm	25	32	40	50
Concentrate feed DN	mm	15	15	20	20
Voltage/frequency	V AC / Hz	400/50	400/50	400/50	400/50
Power uptake	kW	2.5	3.2	5.5	7.0



2.1 Polymer Preparation and Metering Systems

Identity Code Ordering System for Oscillating Systems ULTRMAT ULPa

ULPa	Type / Tank size / Discharge volume
0400	Oscillating system / 2x400 l / 400 l/h
1000	Oscillating system / 2x1,000 l / 1,000 l/h
2000	Oscillating system / 2x2,000 l / 2,000 l/h
4000	Oscillating system / 2x4,000 l / 4,000 l/h
Design	
N	Standard
S	Mirror-imaged
Electrical Connection	
A	400 V AC, 50/60 Hz (3ph, N, PE)
Control	
0	PLC S7-1200
1	PLC S7-1200 with PROFIBUS® (DP/DP coupler)
2	PLC Programmable Logic Controller S7-1200 with PROFINET (PN/PN coupler)
3	PLC Programmable Logic Controller S7 – 1200 with MODBUS TCP
Options	
0	None
Powder feeder	
P0	None
P1	Powder feeder (0400)
P2	Powder feeder (1000)
P3	Powder feeder (2000)
P4	Powder feeder (4000)
Vibrator for powder feeder	
0	None
1	With vibrator for powder feeder
Powder conveyor FG205, add-on hopper	
0	None
1	With add-on hopper 50 l (0400, 1000)
2	With add-on hopper 75 l (2000)
3	With add-on hopper 100 l (4000)
4	With add-on hopper 50 l + powder conveyor unit FG205 (0400, 1000)
5	With add-on hopper 75 l + powder conveyor unit (2000)
6	With add-on hopper 100 l + powder conveyor unit (4000)
7	With adapter cover + powder conveyor unit
Liquid concentrate pump	
L0	None
L1	With sigma
L2	With SPECTRA
L3	Prepared for sigma
L4	Prepared for SPECTRA
L5	Prepared for sigma, no bracket
L6	Prepared for SPECTRA, no bracket
L7	Prepared for peristaltic pump
L8	With peristaltic pump
Monitoring for liquid concentrate pump	
0	None
1	With capacitive sensor for concentrate tank
2	With flow monitor, only SPECTRA
3	With capacitive sensor and flow monitor, only SPECTRA
Water pipework with wetting fitting	
0	Without wetting cone (liquid version)
1	Wetting cone, PVC (0400)
2	Wetting cone, PVC (1000, 2000)
3	Wetting cone, PVC (4000)
4	Wetting cone, PP (0400)
5	Wetting cone, PP (1000, 2000)
6	Wetting cone, PP (4000)
Language	
BG	Bulgarian
CN	Chinese
CZ	Czech
DA	Danish
DE	German
EL	Greek
EN	English
ES	Spanish
ET	Estonian
FI	Finnish
FR	French
HR	Croatian
HU	Hungarian
IT	Italian
LT	Lithuanian
LV	Latvian

2.1 Polymer Preparation and Metering Systems

2.1.7

Metering System ULTROMAT ULDa

A good solution when preparing polymer solutions as flocculation aids.

Extraction rates of up to 2,000 l/h



The ProMinent metering system ULTROMAT ULDa is an automatic polyelectrolyte preparation system. It is useful wherever polymers need to be automatically prepared as polymer solutions to act as flocculation aids.

ULTROMAT ULDa double-decker systems are used to process liquid and powdered polymers. The system is comprised of two separate PP tanks, one stacked on top of the other. Product carry-over is thereby avoided. The polymer solution is batched in the upper storage tank and can be transferred to the lower storage tank once the maturing time has elapsed.

Your Benefits

- Processing of liquid polymer (0.05 – 1.0 %) and powdered polymers (0.05 – 0.5 %)
- No mixing of fresh and matured polymer
- Wide range of versions for specific applications
- Operator-controlled input of solvent concentration and calibration of powder feeder and liquid concentrate pump
- Water apparatus with flow meter and fitting set for the dilution water
- Gentle mixing of the polymer solution (electric stirrer)
- Pressure sensor for the measurement of the liquid level
- Version with terminal box available on request

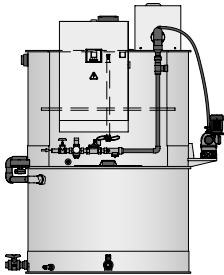

ULTROMAT ULDa for powder and liquid polymers

Technical Details

Siemens S7 – 1200 compact control system and KTP 400 touch panel

- PLC optionally fitted with PROFIBUS® and DP/DP coupler
- Optionally fitted with Profinet and PN/PN coupler
- Optionally fitted with Modbus TCP

Field of Application

- Potable water treatment
- Wastewater treatment (industry and local authorities)
- Sludge de-watering
- Paper production

The following types of polymer can be processed:

- Liquid polymers (0.05 – 1.0 %)
- Powdered polymers (0.05 – 0.5%)

Selectable components:

- Tank size/extraction rate
- Construction (normal or mirror image)
- Electrical connection
- Control S7 – 1200 (with and without PROFIBUS®/PROFINET/Modbus TCP)
- Powder feeder unit
- Vibrator for powder feeder unit (promotes the movement of polymer)
- Powder conveyor FG205/add-on hopper (for filling and feeding the powder feeder unit)
- Liquid concentrate pumps of types sigma, SPECTRA, DULCOFLEX DFXa
- Monitor for liquid concentrate pump (float switch/flow monitor)
- Flush valve (Y-flush inlet or wetting cone)
- Language (pre-set language for the control panel)

The standard scope of delivery includes among other things:

- Pause function/operating message/running dry function
- Monitoring of the post dilution unit
- Lifting lugs

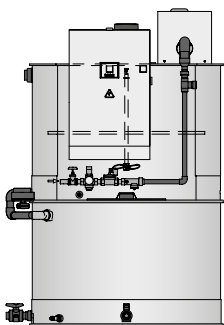

ULTROMAT ULDa for powder polymers

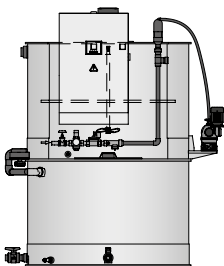

ULTROMAT ULDa for liquid polymers



2.1 Polymer Preparation and Metering Systems

Technical Data

		400	1,000	2,000
Tank contents	l	2 x 400	2 x 1,000	2 x 2,000
Raw water feed	l/h	1,600	4,000	8,000
Water pressure	bar	3...5	3...5	3...5
Powdered polymer	kg/h	0.5...11	0.8...18	3.6...55
Length	mm	1,638	1,902	2,288
Width	mm	1,351	1,615	2,005
Height	mm	2,030	2,514	3,149
Water connection for raw water	Inch	1	1	1 1/2
Discharge nozzle DN	mm	25	32	40
Concentrate feed DN	mm	15	15	20
Voltage/frequency	V AC / Hz	400/50	400/50	400/50
Power uptake	kW	1.5	2.6	3.2





2.1 Polymer Preparation and Metering Systems

Identity Code Ordering System for Double-deck System ULTROMAT ULDa

ULDa	Type / Tank size / Discharge volume
0400	Double-deck system / 2x400 l / 400 l/h
1000	Double-deck system / 2x1,000 l / 1,000 l/h
2000	Double-deck system / 2x2,000 l / 2,000 l/h
Design	
N	Standard
S	Mirror-imaged
Electrical Connection	
A	400 V AC, 50/60 Hz (3ph, N, PE)
Control	
0	PLC S7-1200
1	PLC S7-1200 with PROFIBUS® (DP/DP coupler)
2	PLC Programmable Logic Controller S7-1200 with PROFINET (PN/PN coupler)
3	PLC Programmable Logic Controller S7 – 1200 with MODBUS TCP
Options	
0	None
Powder feeder	
P0	None
P1	Powder feeder (0400)
P2	Powder feeder (1000)
P3	Powder feeder (2000)
Vibrator for powder feeder	
0	None
1	With vibrator for powder feeder
Powder conveyor FG205, add-on hopper	
0	None
1	With add-on hopper 50 l
2	With add-on hopper 75 l
3	With add-on hopper 100 l
4	With add-on hopper 50 l + powder conveyor unit
5	With add-on hopper 75 l + powder conveyor unit
6	With add-on hopper 100 l + powder conveyor unit
7	With adapter cover + powder conveyor unit
Liquid concentrate pump	
L0	None
L1	With Sigma
L2	With SPECTRA
L3	Prepared for sigma
L4	Prepared for SPECTRA
L5	Prepared for sigma, no bracket
L6	Prepared for SPECTRA, no bracket
L7	Prepared for peristaltic pump
L8	With peristaltic pump
Monitoring for liquid concentrate pump	
0	None
1	With capacitive sensor for concentrate tank
2	With flow monitor, only SPECTRA
3	With capacitive sensor and flow monitor, only SPECTRA
Water pipework with wetting fitting	
1	Y-wetting fitting, PVC (0400)
2	Y-wetting fitting, PVC (1000)
3	Y-wetting fitting, PVC (2000)
4	Wetting cone, PVC (0400)
5	Wetting cone, PVC (1000)
6	Wetting cone, PVC (2000)
7	Wetting cone, PP (0400)
8	Wetting cone, PP (1000)
9	Wetting cone, PP (2000)
Language	
BG	Bulgarian
CN	Chinese
CZ	Czech
DA	Danish
DE	German
EL	Greek
EN	English
ES	Spanish
ET	Estonian
FI	Finnish
FR	French
HR	Croatian
HU	Hungarian
IT	Italian
LT	Lithuanian
LV	Latvian



2.1 Polymer Preparation and Metering Systems

2.1.8 Metering System DULCODOS UL1a (Inline System Liquid)

Metering system specifically designed for the batching of a fully activated liquid polymer solution

Extraction volume 100 – 400 l/h against 4.5 bar



The polymer preparation system DULCODOS UL1a is an inline system and processes liquid polymers to produce a fully activated solution. It is ideally equipped for your application with integrated mixing and maturing chamber and novel peristaltic metering pump.



The compact inline preparation station DULCODOS UL1a features a special mixing chamber in which liquid polymer is added by peristaltic or metering pumps. Optimum mixing with water produces a fully activated polymer solution with a maturing time of approx. 15 min in the maturing chamber.

The concentration of the polymer solution can be simply adjusted on the touch panel.

Continuous polymer preparation output in l/h can be specified as an option. The polymer preparation system works reliably and conserves resources thanks to its optimum process control.

Your Benefits

- Precise processing of liquid polymers (0.05 - 1.0 %) with a 50 % active ingredient
- Highly efficient mixing and maturing chamber for emulsions / dispersions and water
- Operator-managed input of the concentration with proportional metering
- Compact design with various installation options
- Optional operator-managed specification of the polymer preparation output in l/h
- System runs directly against a 4.5 bar back pressure, there is no need for a chemical transfer pump

Technical Details

- Proportional metering as standard
- 3 system types with different equipment can be selected:
 - basic - manual flow adjustment, manual flushing
 - medium - automatic flow control, manual flushing
 - comfort - automatic flow control, automatic flushing
- Integrated post dilution unit available as an option
- Choice of peristaltic or metering pumps:
 - Peristaltic pumps DFXa 0530 and 0565 for back pressures of up to max. 4.5 bar
 - Metering pumps gamma/ X with HV head up to 4.5 bar
 - Metering pumps Sigma up to 4.5 bar
- Compact controller Schneider Electric TM241 and touch panel STO735 4.3"
 - Optionally fitted with Ethernet/Modbus TCP
 - Optionally fitted with PROFIBUS®

Field of Application

- Sludge dewatering and sludge thickening
- Wastewater treatment (industry and local authorities)
- Drinking water treatment

The following types of polymer can be processed:

- Liquid polymers (0.05 – 1.0 %)
- As emulsions or dispersions

2.1 Polymer Preparation and Metering Systems

Selectable components:

- Freely selectable preparation capacity
- Configuration versions
- Electrical connection
- Control versions with or without data communication
- Operating versions
- Liquid polymer metering pumps
 - Peristaltic pump DFXa
 - Metering pump gamma/ X
 - Metering pump sigma/ X S1Cb
- Monitoring of low liquid polymers
- Raw water booster pump
- Post dilution unit
- Language



2.1 Polymer Preparation and Metering Systems

Technical Data

Type		100	200	400
Max. extraction rate	l/h	100	200	400
Max. extraction rate/Inline with post-dilution	l/h	450	900	1,800
Maturation time	min	15	15	15
Max. water pressure	bar	8	8	8
Min. water pressure*	bar	4	4	4
Back pressure, max.	bar	4.5	4.5	4.5
Length	mm	1,200	1,200	1,200
Width	mm	800	800	800
Height	mm	1,900	1,900	1,900
Water connection DN	mm	25	25	25
Discharge nozzle DN	mm	25	25	25
Protection class		IP 55	IP 55	IP 55
Power supply V/Hz		220-240/50-60	220-240/50-60	220-240/50-60

* if the water pressure is lower, use the pressure boost option



Note: Batch preparation stations are still at the development stage.

2.1 Polymer Preparation and Metering Systems

Identity code ordering system for DULCODOS ULLa inline systems liquid

ULLa	Type
100	Inline batching station 50 - 100 l/h, K= 1.0 %
200	Inline batching station 94 - 200 l/h, K= 1.0 %
400	Inline batching station 188 - 400 l/h, K= 1.0 %
Design	
NP	Standard/wall-mounted
NV	Standard/vertical to the wall
SP	Mirror-inverted/wall-mounted
SV	Mirror-inverted/vertical to the wall
Electrical Connection	
EU	220-240 VAC 50 Hz
WL	220-240 V AC 60 Hz
US	100-120 VAC 60 Hz
Control and data communication	
0	With PLC Schneider PLC TM241 series
1	With PLC Schneider PLC TM241 series + Ethernet switch box / Modbus TCP
2	With PLC Schneider PLC TM241 series + Profibus
3	With PLC Schneider PLC TM241 series + Profinet
Operating version	
B	Basic - manual flow adjustment, proportional metering, manual flushing
M	Medium - automatic flow control, proportional metering, manual flushing
C	Comfort - automatic flow control, proportional metering, automatic flushing
Metering pump for liquid polymer	
L1	Peristaltic pump DFXa 0530 for ULLa 100, 200, 400 (up to 3 (5) bar back pressure)
Liquid polymer tank liquid level monitor	
0	None
1	Capacitive sensor
Raw water booster pump	
B0	None
BP	Prepared/with control signal
B1	Installed
Post-dilution unit	
D0	None
D1	Fitted for basic version
D2	Fitted for medium+comfort version
additional maturing/storage tank with equipment	
AO	None
Stirrer for maturing/storage tank	
0	None
Feed pump for maturing/storage tank	
F0	None
Language	
CZ	Czech
DE	German
EN	English
ES	Spanish
FI	Finnish
FR	French
IT	Italian
PT	Portuguese
SV	Swedish
ZH	Chinese

2



2.1 Polymer Preparation and Metering Systems

2.1.9 Metering System ULTROMAT MT for Batch Operation

This manual polymer batching station is worthwhile if you only work with small quantities.

Capacity range 120 – 3,800 l/h



Manual polymer batching station ULTROMAT MT: Perfect metering system for the processing of small quantities of liquid and powdered polymers: extremely robust and cost-effective.

The ULTROMAT MT is ideal for individually batching polymer solutions where there is no need for automatic operation. The powdered polymer is added manually through the wetting cone to the maturing tank and mixed by the stirrer. After the maturing time, the flocculant solution can then be metered into the application.

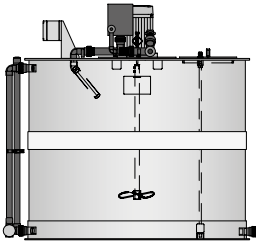

Your Benefits

- Ideal for use where there is no need for continuous operation
- Manual addition of flocculants
- Robust and cost-effective
- Round polypropylene batching tank
- Flushing system with wetting cone and injector
- Gentle mixing of the polymer solution

Technical Details

- Slowly-running stirrer
- Flushing system
- Level switch (Low flow, Min, Max contact)
- Terminal box

Field of Application

- Potable water treatment
- Wastewater treatment (industry and local authorities)
- Sludge de-watering

The systems consist of:

- 1 PP preparation tank
- 1 flushing system for flushing and wetting the powder with wetting cone, injector and fitting set for the dilution water
- 1 slow-rotating electric stirrer
- 1 level switch with three switching points
- 1 terminal box

ULTROMAT MT

	Order no.
MT 140, stirrer 0.18 kW	1037073
MT 250, stirrer 0.55 kW	1037094
MT 500, stirrer 0.75 kW	1037095
MT 1000, stirrer 1.1 kW	1037096
MT 2000, stirrer 2.2 kW	1037097
MT 3000, stirrer 2.2 kW	1037098
MT 4000, stirrer 3 kW	1037099



2.1 Polymer Preparation and Metering Systems

Technical Data

Type		MT 140	MT 250	MT 500	MT 1000	MT 2000	MT 3000	MT 4000
Discharge volume	l/h	120	210	440	920	1,890	2,850	3,800
Useful tank volume (with reserve of approx.10%)	l	120	210	440	920	1,890	2,850	3,800
Diameter of tank	mm	640	650	850	1,260	1,460	1,770	1,650
Height of tank	mm	714	1,116	1,018	1,016	1,518	1,620	2,072
Height	mm	1,003	1,405	1,309	1,320	1,875	1,998	2,496
Water connection DN	mm	20	20	20	25	32	40	40
Discharge nozzle DN	mm	20	20	20	25	32	40	40
Voltage/frequency	V AC / Hz	400/50	400/50	400/50	400/50	400/50	400/50	400/50
Power uptake	kW	0.18	0.55	0.75	1.10	2.20	2.20	3.00

The systems are also available with flushing water fitting, level indicator and switchgear.

2.1 Polymer Preparation and Metering Systems

2.1.10 ULTROMAT and DULCODOS Accessories Including Big Bag Systems

ULTROMAT post-dilution unit VS

The ULTROMAT post-dilution units are fully assembled units for the post-dilution of polymer solutions, essentially consisting of:

- 1 water apparatus for the dilution water with manual shut-off valve, pressure reducer, 24 V DC solenoid valve and float flow meter including minimum contact
- 1 pipework for the polymer solution to be diluted including check valve
- 1 static mixer integrated into the output pipework for mixing the stock solution with the dilution water

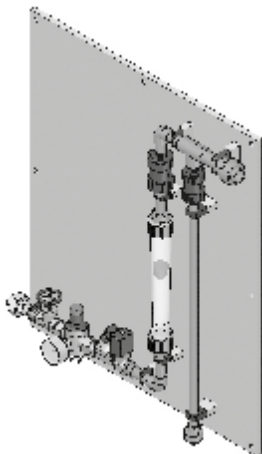

	Process solution	Order no.
VS 1000	1,000 l/h	1096130
VS 2000	2,000 l/h	1096131
VS 5000	5,000 l/h	1096132
VS 10000	10,000 l/h	1096133
VS 20000	20,000 l/h	1096134
VS 30000	30,000 l/h	1096135
VS 50000	50,000 l/h	1096136

ULTROMAT post-dilution unit VS-IP with flow measurement

The ULTROMAT post-dilution units are fully assembled units for the post-dilution of polymer solutions, essentially consisting of:

- 1 water apparatus for the dilution water with manual shut-off valve, pressure reducer, 24 V DC solenoid valve and float flow meter including minimum contact
- 1 pipework for the polymer solution to be diluted including check valve and inductive flow meter
- 1 static mixer integrated into the output pipework for mixing the stock solution with the dilution water

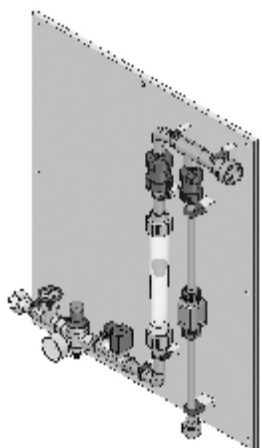

	Process solution	Order no.
VS 1000 IP	1,000 l/h	1096137
VS 2000 IP	2,000 l/h	1096138
VS 5000 IP	5,000 l/h	1096139
VS 10000 IP	10,000 l/h	1096140
VS 20000 IP	20,000 l/h	1096142
VS 30000 IP	30,000 l/h	1096143
VS 50000 IP	50,000 l/h	1096144

ULTROMAT powder conveyor FG 205

The ULTROMAT powder conveyor FG 205 is used to top up the dry material feeder of the DULCODOS systems with commercially available powdered polymers. A suction hose and a suction lance are used to draw the powder from the storage container (Big Bag, powder storage tank) into the powder conveyor and to transport it through a flap into the dry material feeder of the polymer dissolving station. The powder conveyor is self-controlled and simply needs a 230 V single-phase connection. External switch contacts are not needed. Approx. 40 kg powdered polymer can be transported per hour depending on the properties of the powder. The 4-metre-long metering hose and extraction nozzle are included in the scope of delivery.

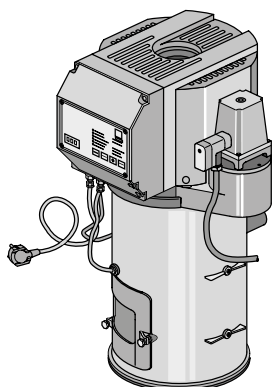

	Minimum pump capacity	Order no.
Powder conveyor FG 205 230 VAC/50 Hz	40 kg/h	1000664
Powder conveyor FG 205 230 VAC/60 Hz	40 kg/h	1061422



2.1 Polymer Preparation and Metering Systems

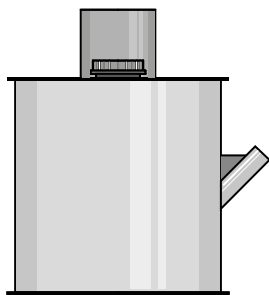

Powder pre-storage tank

The powder pre-storage tank is used for interim storage of powdered polymers that are delivered in Big-Bags. The Big-Bag is suspended over the tank on a frame and emptied into the powder pre-storage tank.

Powder pre-storage tank	Order no. 1005573
--------------------------------	-----------------------------

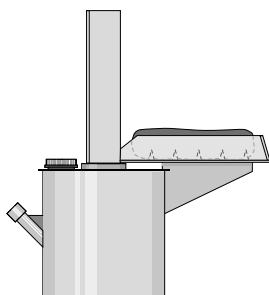

Powder pre-storage tank with bag tipper

The powder pre-storage tank with bag tipper is used for interim storage of powdered polymers delivered in 25 kg sacks.

Powder pre-storage tank with bag tipper	Order no. 1025137
--	-----------------------------

Big Bag emptying units

These emptying units are used to hold and empty Big Bags weighing up to 1,000 kg. A powder hopper is used to transfer the powder into a special feed unit, such as powder feeder FG 205, thereby ensuring the supply of powder to the dry feeder of the polymer preparation station.

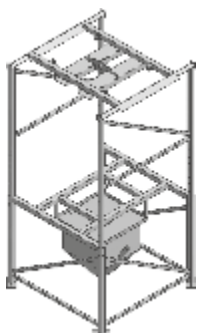

Big Bag emptying unit, standard

- Standard design in painted steel
- Integrated suspension cross for the Big Bags
- Suitable for loading with crane or fork-lift
- Powder storage tank with approx. 200-litre content

Big Bag emptying unit, standard	Order no. 1083075
--	-----------------------------



2.1 Polymer Preparation and Metering Systems

Big Bag emptying unit with electrical lifting equipment

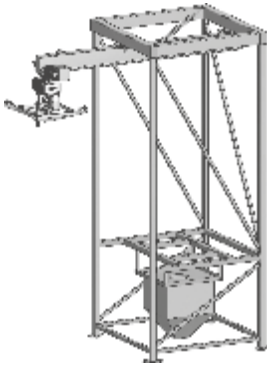

- Height-adjustable frame
- Standard design in painted steel
- Integrated travelling crane
- Electrical lifting equipment with suspension cross for the Big Bags
- Powder storage tank with approx. 200-litre content

Big Bag emptying unit with electrical lifting equipment

Order no.
1083076

Big Bag emptying unit with dust-free emptying option

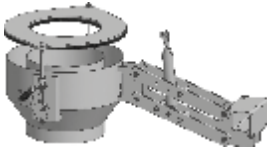

- Additional unit under the Big Bag including dust filter

Big Bag emptying unit with dust-free emptying option

Order no.
1083077

2.1 Polymer Preparation and Metering Systems

2.1.11 Batching Stations and Metering of Powdered and Liquid Polymer Solutions PolyRex

Preferred fields of application include:

- Potable water treatment
- Wastewater treatment (industry and local authorities)
- Sludge dewatering
- Paper production

3 different system concepts are available:

- Preparation system with vacuum conveyor (PolyRex)
- Preparation system with Big Bag emptying unit (PolyRex Big Bag)
- Preparation system for common liquid polymers (PolyRex Liquid)

PolyRex is a turnkey system for batch-wise treatment of powder and liquid polymers. Common to all PolyRex systems is the use of 2 stainless steel tanks; one batching maturity tank and one supply tank, either with a double-decker design or side by side.

PolyRex uses a highly effective, three-stage process for flushing, water acceleration and gentle but efficient mixing in the mixing tank to produce a homogeneous, activated polymer solution.

The batch preparation system provides exceptional properties compared to a continuous system. This is because there is no short-circuiting effect. The polymer particles cannot run through the process without being activated.

The proven multi-screw feeder guarantees reliable emptying without pulsation with extremely precise metering. This ensures precise batch composition. If conventional liquid polymers are used, a reliable eccentric screw pump is used, which guarantees reliable and ultra-precise metering.

PolyRex systems are equipped with a compact PLC and touch panel. As an option, the compact PLC can be fitted with a PROFIBUS® or Ethernet module. Commissioning could not be simpler. Input of the solvent concentration as well as calibration of the powder feeder unit and liquid concentrate pump is user-managed. Alarm messages and warnings are shown on the display.

Application example for a PolyRex polymer preparation system

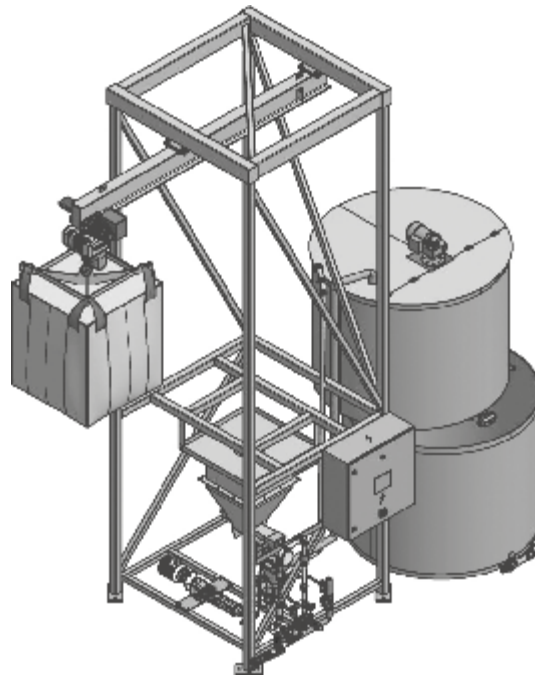

2.1 Polymer Preparation and Metering Systems

2.1.12 Metering System PolyRex

PolyRex can do more: Processes liquid and powdered polymers.

Capacity range of up to 8200 l/h



The metering system PolyRex is a double-decker batching station for the processing of liquid and powdered polymers. It consists of the feed and mixer unit and the two stainless steel double-decker tanks. The polymers used are ideally utilised.

The upper storage tank represents the batching/ maturing tank. The lower tank is the storage tank for the prepared polymer solution.

The powdered polymer is transported to the powder feeder by a vacuum conveyor using 2 conveyor screws and mixed into 3 layers with water in the underlying mixer unit; wetting cone, water injector and stirrer in batching tank. The solution is then transferred to the upper storage tank using the water pressure of the diluting water. The polymer solution matures completely in this, a short circuit effect is avoided. After maturing, the solution can be transferred to the lower storage tank via the motorised valve.

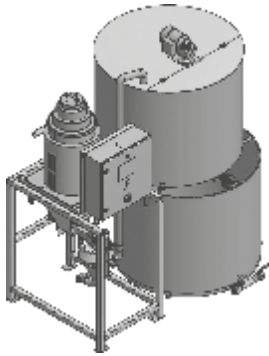

Your Benefits

Compact controller ABB AC500 PM573-ETH and touch panel CP635

- Dust-free filling of the powder storage tank thanks to use of a vacuum conveyor
- Double screw metering unit with 2 counter-rotating conveyor screws enables low-pulsation metering with a high level of dosing precision.
- Pressure reducer for a constant water supply
- Effective 3-phase mixing of the polymer solution
- No short-circuiting effect: polymer particles cannot pass through the process without activation

Technical Details

- Vacuum conveyor for filling from small powder bags
- Powder top hopper with inspection glass
- Powder level probe for detecting an empty top hopper
- Shut-off damper on feeder to prevent moisture infiltration
- Wetting cone in stainless steel for dissolving of the powder
- Water apparatus with wetting cone and injector to produce an effective and homogeneous polymer solution from powdered polymers
- Stainless steel tank for maturing and feeding the polymer solution in slightly offset double-deck arrangement for PolyRex 0.6 - 8.4, with adjacent tanks for PolyRex Maxi 11 - 23
- Motorised valve to dispense the solution into the storage tank
- Slow-running stirrer in the upper storage tank for gentle mixing of the polymer solution

Field of Application

- Potable water treatment
- Wastewater treatment (industry and local authorities)
- Sludge de-watering
- Paper production

Options

- Batching commercially-available liquid polymers using a progressive cavity pump
- Heating elements at wetting cone entrance and at feeder output (recommended for environment with high air humidity)
- PROFIBUS® or Ethernet communication
- Compact controllers from Siemens or Allen Bradley on request
- Water apparatus and piping in stainless steel design

Accessories

- Re-dilution with highly effective static mixer
- Progressive cavity pump with speed control
- Electromagnetic flow meter for precise control of the metering pump



2.1 Polymer Preparation and Metering Systems

Technical Data

	Tank contents	Discharge volume	Polymer dosing capacity
	m ³	l/h	kg/h
PolyRex 0.6	2 x 0.3	240	1.2
PolyRex 1.0	2 x 0.6	460	2.3
PolyRex 2.0	2 x 1.0	940	4.7
PolyRex 3.0	2 x 1.5	1,280	6.4
PolyRex 4.0	2 x 2.0	1,900	9.5
PolyRex 5.4	2 x 2.7	2,400	12.0
PolyRex 6.6	2 x 3.3	3,200	16.0
PolyRex 8.4	2 x 4.2	3,820	19.2
PolyRex Maxi 11	2 x 5.5	5,100	25.5
PolyRex Maxi 16	2 x 8.0	6,600	33.0
PolyRex Maxi 23	2 x 11.5	8,200	41.0



2.1 Polymer Preparation and Metering Systems

2.1.13 Metering System PolyRex Big Bag

PolyRex can do more: Processes liquid and powdered polymers.

Capacity range of up to 8200 l/h



The metering system PolyRex is a double-decker batching station for the processing of liquid and powdered polymers. It consists of the feed and mixer unit and the two stainless steel double-decker tanks. The polymers used are ideally utilised.



The upper storage tank represents the batching/ maturing tank. The lower tank is the storage tank for the prepared polymer solution.

The powdered polymer is transported to the powder feeder by a vacuum conveyor using 2 conveyor screws and mixed into 3 layers with water in the underlying mixer unit; wetting cone, water injector and stirrer in batching tank. The solution is then transferred to the upper storage tank using the water pressure of the diluting water. The polymer solution matures completely in this, a short circuit effect is avoided. After maturing, the solution can be transferred to the lower storage tank via the motorised valve.

Your Benefits

Compact controller ABB AC500 PM573-ETH and touch panel CP635

- Flexible and height-adjustable Big Bag emptying unit with integrated lifting cross for charging by crane or fork-lift
- Double-screw feeder with 2 reverse conveyor screws enables low-pulsation metering with a high level of dosing precision
- Pressure reducer for a constant water supply
- Effective 3-phase mixing of the polymer solution
- No short-circuiting effect: polymer particles cannot pass through the process without activation

Technical Details

- Powder top hopper with inspection glass
- Powder level probe for detecting an empty top hopper
- Shut-off damper on feeder to prevent moisture infiltration
- Wetting cone in stainless steel for dissolving of the powder
- Water apparatus with wetting cone and injector to produce an effective and homogeneous polymer solution from powdered polymers
- Stainless steel tank for maturing and feeding the polymer solution in slightly offset double-deck arrangement for PolyRex 0.6 - 8.4, with adjacent tanks for PolyRex Maxi 11 - 23
- Motorised valve to dispense the solution into the storage tank
- Slow-running stirrer in the upper storage tank for gentle mixing of the polymer solution

Field of Application

- Potable water treatment
- Wastewater treatment (industry and local authorities)
- Sludge de-watering
- Paper production

Options

- Big Bag emptying unit with travelling crane and electrical lifting equipment
- Dust-free emptying, thanks to additional unit under the Big Bag including dust filter
- Batching of commercially available liquid polymers by the use of an eccentric screw pump
- Heating element at the inlet of the wetting cone and/or at the outlet of the metering unit (recommended for environments with high air humidity)
- PROFIBUS® or Ethernet communication
- Compact Siemens or Allen Bradley controller on request
- Water apparatus and piping in stainless steel design

Accessories

- Re-dilution with highly effective static mixer
- Eccentric screw pump with speed control
- Electromagnetic flow meter for the precise control of the metering pump

2.1 Polymer Preparation and Metering Systems

Technical Data

	Tank contents	Discharge volume	Polymer dosing capacity
	m ³	l/h	kg/h
PolyRex 0.6	2 x 0.3	240	1.2
PolyRex 1.0	2 x 0.6	460	2.3
PolyRex 2.0	2 x 1.0	940	4.7
PolyRex 3.0	2 x 1.5	1,280	6.4
PolyRex 4.0	2 x 2.0	1,900	9.5
PolyRex 5.4	2 x 2.7	2,400	12.0
PolyRex 6.6	2 x 3.3	3,200	16.0
PolyRex 8.4	2 x 4.2	3,820	19.2
PolyRex Maxi 11	2 x 5.5	5,100	25.5
PolyRex Maxi 16	2 x 8.0	6,600	33.0
PolyRex Maxi 23	2 x 11.5	8,200	41.0



2.1 Polymer Preparation and Metering Systems

2.1.14 Metering System PolyRex Liquid

The PolyRex can do more: it processes common liquid polymers.

Capacity range of up to 3180 l/h



The metering system PolyRex is a double-decker batching station for the processing of liquid polymers. It consists of the feed and mixer unit and the two stainless steel double-decker tanks. The polymers used are ideally utilised.

The upper storage tank represents the batching/maturing tank. The lower tank is the storage tank for the prepared polymer solution.

The liquid polymer is fed in by an eccentric screw pump and an injection nozzle and mixed with water in 2 stages by means of a water injector and a stirrer in the batching/maturing tank. The solution is transferred to the upper storage tank using the water pressure of the diluting water. The polymer solution can fully mature in this, avoiding a short-circuiting effect. After maturing, the solution can be transferred to the bottom storage tank via the motorised valve.

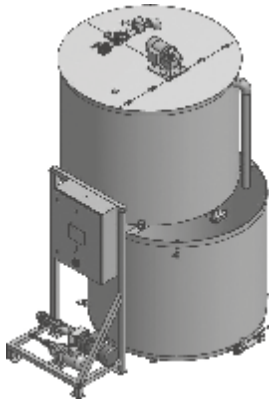

Your Benefits

Compact controller ABB AC500 PM573-ETH and touch panel CP635

- Reliable eccentric screw pump for metering commercially available polymers
- High energy mixing process
- Unique injection nozzle prevents clogging of the liquid polymer
- Pressure reducer for a constant water supply
- Effective 2-phase mixing of the polymer solution
- No short-circuiting effect: polymer particles cannot pass through the process without activation

Technical Details

- Water apparatus with wetting cone and injector to produce an effective and homogeneous polymer solution
- Double-decker storage tank made of stainless steel for maturing and storing the polymer solution
- Motorised valve to dispense the solution into the storage tank
- Slow-rotating stirrer in the upper storage tank for the gentle mixing of the polymer solution

Field of Application

- Wastewater treatment (industry and local authorities)
- Sludge de-watering

Options

- PROFIBUS® or Ethernet communication
- Compact controllers from Siemens or Allen Bradley on request
- Water apparatus and piping in stainless steel design

Accessories

- Re-dilution with highly effective static mixer
- Eccentric screw pump with speed control
- Electromagnetic flow meter for precise control of the metering pump

Technical Data

	Tank contents	Discharge volume	Polymer dosing capacity
	m ³	l/h	kg/h
PolyRex Liquid 1.0	0.5	1,060	5.3
PolyRex Liquid 2.0	1.0	1,900	9.5
PolyRex Liquid 3.0	1.5	2,480	12.4
PolyRex Liquid 4.0	2.0	3,180	15.9

Note: The metering rate of liquid polymer in kg/h denotes a 100 % active ingredient content. Naturally, the concentration of the active ingredient in the systems can be adjusted to the commercially available liquid polymers with a 30 - 60 % active ingredient percentage.

2.1 Polymer Preparation and Metering Systems

2.1.15

PolyRex Accessories – Mixing Systems

The PolyRex and PolyRex Big Bag systems are fitted with special mixing systems for powdered polymer.

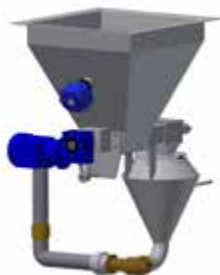

Efficient mixing systems for polymers

	Use	Polymer	Mixing unit	Application/benefits
PolyRex Classic	Standard	<ul style="list-style-type: none"> • Powder • Liquid 	Cyclonic wetting cone	<ul style="list-style-type: none"> • Reliable and effective hydration



	Use	Polymer	Mixing unit	Application/benefits
PolyRex Optimo	Option	<ul style="list-style-type: none"> • Powder • Liquid 	Sealed system with heated conical wetting area and integrated mixing pump	<ul style="list-style-type: none"> • Highly efficient polymer mixing • Reliable and dust-free • Very low powder consumption



	Use	Polymer	Mixing unit	Application/benefits
PolyRex Aero Mix	Option	<ul style="list-style-type: none"> • Powder 	Closed system with pneumatic powder conveyance, fans, water nozzles, mixing tank	<ul style="list-style-type: none"> • High air humidity • High ambient temperature

2





2.1 Polymer Preparation and Metering Systems

2.1.16 TOMAL® Multi-Screw Feeder

Reduce costs with precision and reliability when metering dry products.

Capacity range 0.4 – 215 m³/h

Its unique construction makes the multi-screw feeder ideally suited for metering powders and granulates.

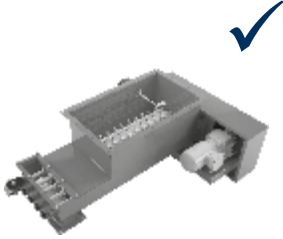

TOMAL® metering units are volumetric multi-screw feeders and can be integrated into almost every process, whether continuously or intermittently, into many applications in which solids need to be metered safely and precisely.

The metering unit is ideally designed and selected to your customer-specific requirements.

Your Benefits

- Safe silo emptying
- Excellent dosing precision better than ± 1% with constant bulk weight/density
- Linear discharge curve

Technical Details

- Robust construction for low wear
- Number of intermeshed and counter-rotating feeder screws, which form a blocking zone and thus prevent blind 'co-rotation' of the solid
- Material extraction along the entire active inlet surface of the metering unit
- Self-cleaning construction

Field of Application

- Wastewater treatment
- Paper industry
- Flue gas cleaning
- Chemical industry
- Glass and ceramic industry

Options

- Weighing technology can be added to the volumetric TOMAL® metering unit to form a gravimetric metering system. This is ideal with large fluctuations in bulk weight.
- Level sensors to detect bridge formation

Examples of typical metered products

- | | | |
|---------------------|--------------------------|-----------------------|
| • Active carbon | • Lignite coke HOK® | • Sodium bicarbonate |
| • Aluminium sulfate | • Limestone meal | • Sodium carbonate |
| • Bentonite | • Magnesium sulfate | • Sodium hydrosulfite |
| • Calcium hydroxide | • Magnesium oxide | • Starch |
| • Cement | • Plaster | • Talcum |
| • Flue ash | • Polymers | • Urea |
| • Fluoride | • Potassium permanganate | • Wood powder |
| • Iron oxide | • Soap pellets | • Zinc oxide |
| • Iron sulfate | | |

2.2 Metering and Emptying Station DULCODOS SAFE-IBC

2.2.1 Metering and Emptying Station DULCODOS SAFE-IBC

Safety as a priority with the reliable metering of liquid chemicals.

Storage and drainage of IBCs up to 1,000 l – metering of chemicals up to 1,000 l/h



The metering and emptying station DULCODOS SAFE-IBC provides your process with chemicals interruption-free. It conforms to the modified legislature for liquids harmful to water in accordance with the German Ordinance for Systems Handling Substances Harmful to Water AwSV.



DULCODOS SAFE-IBC is a special metering and emptying station for Intermediate Bulk Containers (IBC) with almost complete residual drainage.

The customer positions and fixes the IBC on the respective installation surface of the retaining tank, which is slightly inclined forwards. Using leak-proof safety couplings and hoses, the IBC is connected to an intermediate tank of approximately 200 litres fitted to the left side of the retaining tank. Alternatively, the station can be ordered with a standpipe and tank volume of approx. 60 litres.

This buffer volume ensures an uninterrupted process when changing the IBC. The visual level indicator and a level measurement function with alarm messages also allow IBC changes to be planned more efficiently. The station is equipped with an inspection opening for maintenance purposes.

To ensure reliable metering, a compact metering station can be integrated in the front of the intermediate tank depending on process requirements. This is equipped either with one or two solenoid metering pumps or with one motor-driven metering pump.

Larger metering stations can be configured as required and designed for side mounting on the wall or installation on the floor.

Liquid level measurement in intermediate tank with the new radar liquid level sensor DULCOLEVEL
>From 2024, now built into the standard version of the SAFE IBC

- Measurement without any contact with media
- Indication of the exact liquid level in litres on a mobile phone. This requires the free DULCONNEX Blue app.
- With a 4-20 mA output signal to connect to a PLC
- Or as an option: connection via Bluetooth to a gamma/ X metering pump

NEW

Your Benefits

- Maximum operating safety
- Excellent process reliability due to interruption-free metering in the process
- Secure installation of an IBC on a special roll-under collection pan construction. Any drops are reliably collected and cannot escape at the installation site
- Almost complete residual drainage of the IBC
- Intermediate tank with a volume of approx. 200 litres combined with an integrated metering station
- Collection pan and intermediate tank both have DIBt approval Z-40.21-585
- Special designs for installation in earthquake zones 1 to 3 in accordance with DIN 4149
- Special design with protective housing for outdoor installation on request



2.2 Metering and Emptying Station DULCODOS SAFE-IBC

Technical Details

- Robust welded construction of the PE-HD collection pan with a total volume of 1300 litres
- Internal steel-reinforced PE-HD bracing on all sides
- PE-HD intermediate tank holding approx. 200 l, alternatively PE-HD standpipe holding approx. 60 l can be selected
- For indoor installation at temperatures of up to 35 °C (temporarily up to 40°C)
- Outer dimensions approx. 1840 x 1850 x 2098 mm (W x D x H)
- **Collection pan and intermediate tank both have DIBt approval Z-40.21-585 (German Institute for Building Technology)**
- **For chemicals with a density of up to max. 1.8 kg/dm³**
- **For liquids on the Media lists 40-1.1 published by the DIBt**
- The installation base of the IBC, which is inclined forwards, measures approximately 1010 x 1620 (W x D) with a grille (polyester resin/epoxy-glass resin) on a special load-bearing structure to withstand a maximum load of 2000 kg. There is a stop rail at the rear of the station and a fixing block at the front
- Pallet substructure to roll under collection pan with a height of approx. 100 mm
- **Special designs for installation in earthquake zones 1 to 3 in accordance with DIN 4149, see design versions**
- Connection of the IBC to the intermediate tank or standpipe:
 - dual-acting PP/ FKM quick-release couplings, PP/EPDM options available and for special media
 - Secure storage of the connection once uncoupled from the IBC in a recessed collection tray at the front
 - PVC spiral hose with wire coil, also available in a PE material version as an option
- The intermediate tank or the standpipe act as a compensation vessel for the volume of the IBC, with the principle of communicating pipes technically ruling out the possibility of overfilling
- Standard equipment of the intermediate tank or standpipe:
 - drain connector with shut-off valve for the IBC's hose connector
 - suction-side connector to the metering station with shut-off valve
 - connection for return of the safety overflow line
 - visual level indicator
 - Radar liquid level sensor DULCOLEVEL
 - Screw lid doubles as an inspection opening
 - Ventilation and bleed connectors
- Metering stations for all solenoid metering pumps and motor-driven metering pumps up to sigma/ 3 can be integrated: DSUa mini, DSKa sigma/ 1 - 3
- Metering stations DSUa, DSWb and customer-specific designs can be set up with side wall mounting or floor installation and associated connection hoses
- Fittings and seals in PVC/FKM, PVC/EPDM options available, special versions for special media
- Also available as a mirror-image design
- A chemical vapour barrier with a vapour recovery line to the IBC can be added to the intermediate tank for outgassing media
- A liquid level measurement with ultrasound sensor can be used as an option

Field of Application

- Metering of liquids in chemical and industrial production
- Drinking water treatment
- Cooling water treatment
- Food & beverage
- Electroplating
- Paper industry



2.2 Metering and Emptying Station DULCODOS SAFE-IBC

Design versions

	Order no.
DULCODOS SAFE-IBC 200 I PE standard FKM	1106230
DULCODOS SAFE-IBC 60 I PE standpipe FKM	1106231
DULCODOS SAFE-IBC 200 I PE standard mirror-inverted FKM	1106232
DULCODOS SAFE-IBC 60 I PE standpipe mirror-inverted FKM	1106233
DULCODOS SAFE-IBC 200 I PE standard EPDM	1114974
DULCODOS SAFE-IBC 60 I PE standpipe EPDM	1114975
DULCODOS SAFE-IBC 200 I PE standard mirror-inverted EPDM	1114976
DULCODOS SAFE-IBC 60 I PE standpipe mirror-inverted EPDM	1114977
DULCODOS SAFE-IBC 200 I PE earthquake zones FKM	1114978
DULCODOS SAFE-IBC, 200 I PE mirror image, earthquake zones FKM	1114979
DULCODOS SAFE-IBC 200 I PE earthquake zones EPDM	1114980
DULCODOS SAFE-IBC, 200 I PE mirror image, earthquake zones EPDM	1114981

Options

	Order no.
Design for outgassing media FKM *	1106613
Design for outgassing media EPDM *	1114982
Binding agent PURACARB Media 0.6 litres	1044341
Binding agent PURACARB AM Media 0.6 litres	1044344
Binding agent PK 2050 0.6 litres	1044345
Binding agent CHLOROSORB ULTRA Media 0.6 litres	1044346
Binding agent PURAFIL SP Media 0.6 litres	1044347
Binding agent Purafil SP mix Media	1109584
Indicator cartridge for acid	1024468
Level measurement via 4-stage level switch	1133127
Liquid level measurement with radar sensor DULCOLEVEL to PLC	1126054
Liquid level measurement with radar sensor DULCOLEVEL to gamma/ X	1126055
Level measurement with ultrasonic sensor	1107079
Leakage sensor Maximat® LWC BX	1080055
PE hose groove cover	1029217
PE hose groove cover, mirror imaged	1120990
Supporting bracket SAFE-IBC VA coupling	1130580

* Also order binding agent depending on medium

Spare Parts

	Order no.
IBC coupling DN 25 PP/FKM *	1106580
IBC coupling DN 25 PP/EPDM *	1111534
IBC coupling DN 25 PP / FEP with coated springs *	1120703
IBC coupling DN 25 HA 1.4401 / FKM	1132957
IBC coupling DN 25 HA 1.4401 / EPDM *	1126663
Part A S60x6 with 1" FKM valve *	1114551
Part A S60x6 with 1" EPDM valve *	1114552
PP replacement seal for part A S60X6	1132441
Hose PVC DN 25 - 1 m	1029382
Hose PE DN 25 - approx. 0.8 m	1118254
Hose PE DN 25 – approx. 0.8 m with PE clamps	1126175
Float switch/level measurement (4 items in total fitted)	142086
Set of fittings/seals, fluorocarbon, SAFE-IBC **	1107550
Set of fittings/seals, EPDM, SAFE-IBC **	1107551

* Dry-closing coupling to IBC provided by the customer

** Full replacement of consumables (recommended after 3 years of use at the latest)



2.3 Storage and Process Tanks

2.3.1 PE/PP Storage Tank, General

Safe and reliable handling of chemicals.

Useful capacity 500 l–50,000 l, indoor and outdoor installation



Our plastic storage tanks guarantee compliance with statutory specifications taking into account country-specific approvals, which regulate the production and operation of systems for storage and metering of environmentally hazardous substances.

Production of plastic storage tanks to customers' specific requirements and in accordance with the test certification. Constructional design and production are in compliance with the construction and test guidelines as laid down by the German Institute for Building Technology (DIBt).

After specification of the key requirements, including fill medium, installation place, storage and ambient conditions, as well as service life, a statistical calculation of the storage tank volume is produced which then provides the technical basis for detailed construction drawings.

PE-HD and PP plate material is primarily used.

Your benefits

- Excellent process reliability of the products, thanks to 25 years of experience in the engineering and production of plastic storage tanks.
- Wide diversity of installation components and storage tank accessories
- Selection of a suitable material after testing its chemical resistance and process-specific requirements.
- Excellent manufacturing quality by the use of state-of-the-art plastics processing machines

Field of Application

Suitable for the storage of chemicals. Applications include: Potable water and process water treatment, process technology, wastewater technology, electroplating, swimming pool technology and exhaust air treatment.

2.3 Storage and Process Tanks

2.3.2 PE Storage Tank With General WHG Approval

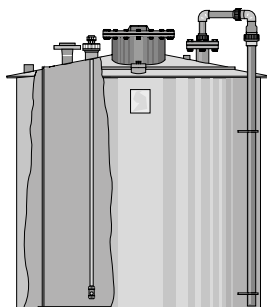

The storage of chemicals hazardous for water (Water Hazard Class (WGK) 0 – 3) is subject to strict, regulatory requirements.

We are a specialist WHG company and supply storage tanks suitable for indoor and outdoor installation, up to a storage volume of 50 m³ in accordance with the statutory requirements in Germany. Manufacturing is subject to external monitoring by the TÜV SÜD. The storage tanks are fully available with monitoring accessories, filling level device, filling equipment, heating equipment, extraction and feeder assembly.

Technical Details

- Test certificate Z-40.21-229 as per the WHG
- Design and production are in compliance with the construction and test regulations as laid down by the German Institute for Building Technology (DIBt)
- For operation at atmospheric pressure at an operating temperature of up to a maximum of 40 °C (media-dependent)
- Material polyethylene PE-HD
- For installation outdoors or indoors
- For installation in earthquake zones with an appropriate technical design
- For chemicals as per the DIBt media list
- Ladder with small platform or stage available as an option

PE-HD Storage Tanks

Usable volume 95% fill level l	Internal diameter mm	External diameter mm	Height of cylindrical section mm	Overall height mm	Weight empty kg
500	800	860	1,050	1,300	50
750	1,000	1,060	1,050	1,300	60
1,000	1,000	1,060	1,350	1,600	70
1,250	1,200	1,260	1,150	1,400	80
1,500	1,200	1,260	1,400	1,650	90
2,000	1,400	1,480	1,400	1,650	100
2,500	1,400	1,480	1,700	1,950	130
3,000	1,600	1,680	1,550	1,800	170
3,500	1,700	1,780	1,550	1,800	190
4,000	1,700	1,780	1,850	2,100	220
5,000	1,900	1,980	1,850	2,100	280
6,000	2,000	2,080	1,950	2,250	350
7,000	2,150	2,250	1,950	2,250	400
8,000	2,150	2,250	2,250	2,550	500
10,000	2,150	2,250	2,900	3,200	600
12,000	2,150	2,250	3,400	3,700	700

PE-HD Collecting Pans

Usable volume 95% fill level l	Internal diameter mm	External diameter mm	Height of cylindrical section mm	Overall height mm	Weight empty kg
500	1,050	1,150	1,030	1,050	40
750	1,250	1,350	1,030	1,050	45
1,000	1,250	1,350	1,280	1,300	50
1,250	1,450	1,550	1,080	1,100	55
1,500	1,450	1,550	1,330	1,350	60
2,000	1,650	1,750	1,280	1,300	70
2,500	1,650	1,750	1,600	1,620	90
3,000	1,850	1,950	1,470	1,500	105
3,500	1,950	2,050	1,470	1,500	120
4,000	1,950	2,050	1,750	1,780	140
5,000	2,150	2,250	1,750	1,780	160
6,000	2,250	2,350	1,900	1,950	200
7,000	2,390	2,490	1,910	1,960	220
8,000	2,390	2,490	2,200	2,250	270
10,000	2,390	2,490	2,750	2,800	350
12,000	2,390	2,490	3,300	3,350	450

Common dimensions, special dimensions and other sizes on request.



2.3 Storage and Process Tanks

Our standard equipped storage tanks and collecting pans with approval marks

For outdoor or indoor installation; other fittings/accessories on request

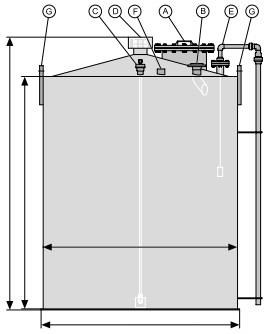

Pos.	Qty.	Designation	500 l – 1,250 l	1,500 l – 2,000 l	2,500 l – 3,500 l	4,000 l – 12,000 l
A	1	Hand hole/man hole, screwed 1.4301	DN 250	DN 250	DN 500	DN 500
B	1	Filling connector with 45° inlet elbow	DN 32	DN 50	DN 50	DN 50
C	1	PVC EPDM di-scharge line	DN 15	DN 15	DN 15	DN 20
D	1	Vent nozzle with hood	DN 80	DN 100	DN 100	DN 100
E	1	Cable level display	DN 80/40	DN 80/40	DN 80/40	DN 80/40
F	1	Threaded sleeve for Rp 2" overfill protection	–	Rp 2"	Rp 2"	Rp 2"
G	2	Lifting eye	–	yes	yes	yes

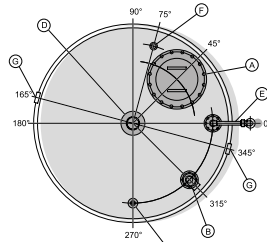

Retaining tanks for outdoor installation

Pos.	Qty.	Designation	500 l – 1,250 l	1,500 l – 12,000 l
H	1	Leakage sensor bracket	Rp 2"	Rp 2"
I	2	Lifting eye	–	yes
J	1	Nameplate	yes	yes
K	1	Rain collar	yes	yes
R	1	Inspection opening	yes	yes
M	1	Floor claw set	yes	yes

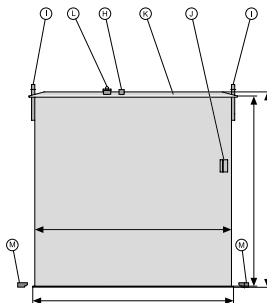

Retaining tanks for indoor installation

Pos.	Qty.	Designation	500 l – 1,250 l	1,500 l – 12,000 l
H	1	Leakage sensor bracket	Rp 2"	Rp 2"
I	2	Lifting eye	–	yes
J	1	Nameplate	yes	yes

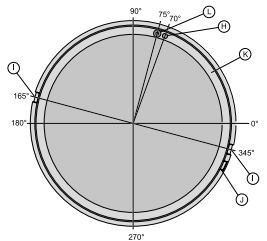

Available as an option:

- Ladder with small platform
- Ladder with stage

2.3 Storage and Process Tanks

2.3.3 Accessories According to the Specifications of the Federal Water Act (WHG) and/or the Ordinance on Installations for the Handling of Substances Hazardous to Water (VAwS)

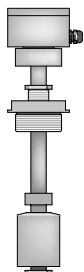

Overflow protection with approval mark

Level probe T200 with float as max. limit level switch for connection to downstream transmitter, see transmitters with test certificate. Length 500 mm adjustable.

Overflow protection with approval mark	Order no. 1009334
---	-----------------------------

Level probe T200 with float used as a max. limit level switch plus downstream transmitter and analysis electronics for 24 VDC with test certificate integrated in the connector head. Length 500 mm adjustable.

Overflow protection with signal output and test certificate	Order no. 1106258
--	-----------------------------

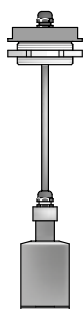

Leakage sensor with approval mark

Leak detection system T200, consisting of level probe with float for connection to downstream transmitter, see transmitters with test certificate.

Leakage sensor with approval mark	Order no. 1009340
--	-----------------------------

Leak detection system T200, consisting of level probe with float for connection and analysis electronics for 24 VDC with test certificate integrated in the connector head.

Leak probe with signal output and test certificate	Order no. 1106260
---	-----------------------------

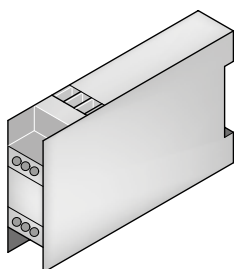

Transmitter with test certificate

For in situ control cabinet installation, compatible with the leak probe and overflow protection

Transmitter with test certificate 230 VAC / 50–60 Hz	Order no. 1009348
Transmitter with test certificate 24 VDC	Order no. 1023865

Alarm indicator unit

For overflow protection and leak probe with test certificate, including beacon light, signal horn and two transmitters

Alarm signalling equipment with test certificate	Order no. 1025437
---	-----------------------------

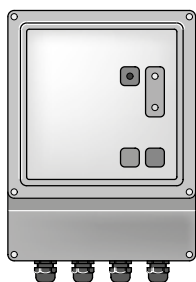



2.3 Storage and Process Tanks

Absorption vessel

For aeration and ventilation of closed storage tanks

Material: Polyethylene PE-HD including connections, ball valve PVC/EPDM and piping to storage tank

Configuration depends on tank volume and storage medium

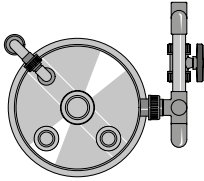
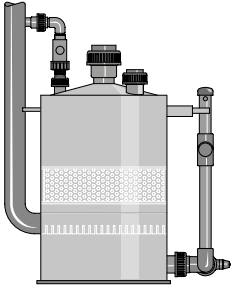

Chemical Vapour Lock

Including binding agent

Configuration depends on tank volume and storage medium

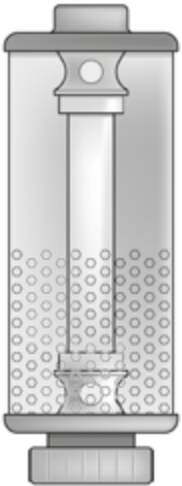

2.3 Storage and Process Tanks

2.3.4 Other Accessories

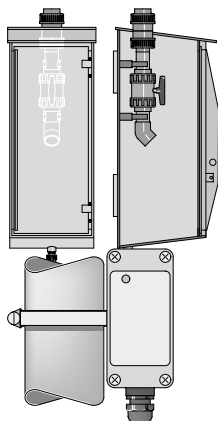

Chemical filling station

Suitable for wall mounting on-site

Material: Polyethylene PE-HD

Dimensions: approx. 420 x 420 x 1000 mm (L x W x H), including ball valve DN 50 PVC/EPDM, threaded connector DN 50 and drip tray with ball valve DN 25

PVC/EPDM connector: Female thread Rp 2"

Other installations, including tank couplings, automatic fittings, heating system etc. are possible

With approval mark for fitting on rope-operated level indicator.

Order no.

Bistable changeover contact

1009349

Storage tank heater

With temperature and level control as dry-running protection, design and price on request, according to storage medium and tank volume

■ Panel radiator with casing and support frame

Optionally with supplementary insulation of the storage tank



Radar liquid level sensor DULCOLEVEL

Liquid level measurement in storage/process tank with the new radar liquid level sensor DULCOLEVEL:

- Indication of the exact liquid level in litres on a mobile phone. This requires the free DULCONNEX Blue app.
- With a 4-20 mA output signal to connect to a PLC or connection via Bluetooth to a gamma/ X metering pump

Order no.

Liquid level measurement with radar sensor DULCOLEVEL to PLC

1126054

Liquid level measurement with radar sensor DULCOLEVEL to gamma/ X

1126055



The following is also needed for tanks installed outdoors in order to protect against rain, dust and wind:

Order no.

protective cowling DULCOLEVEL PP-C-UV

1132245



2.3 Storage and Process Tanks

2.3.5 PP/PE Process Storage Tank, Customised

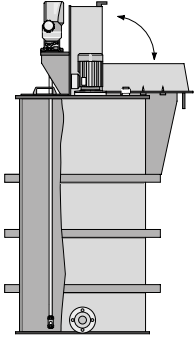

System and process-technology requirements and specifications, and often special requirements demand specially tailored and custom-manufactured PP-PE storage tanks produced using special plate welding machines and bending machines.

Selection of a suitable plate material after checking its chemical resistance.

Additional inserts and attachments, like connecting nozzles, flanges, stirrers, salt dissolving baskets, bag dump equipment, absorption tanks, slanted and cone bottom, optimise and extend their functionality, permitting targeted adaptation of technical problems. A versatile programme of transducers and sensors can also be integrated.

We supply process tanks up to a volume of 50 m³.

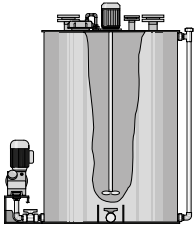

Circular tanks

- Material polyethylene PE-HD or polypropylene PP
- Floor design, flat floor, conical floor, angled floor
- Roof design, flat roof, conical roof or open, suitable for operation at atmospheric pressure at working temperatures of up to 80 °C
- Standard equipment: 2 lifting eyes above a round storage tank with a usable volume of 2000 l

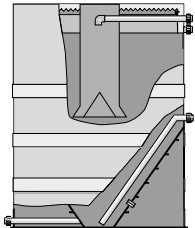

Usable volume 95% fill level l	Internal diameter mm	External diameter mm	Height of cylindrical section mm	Overall height mm
500	800	860	1,050	1,070
750	1,000	1,060	1,050	1,070
1,000	1,000	1,060	1,350	1,370
1,250	1,200	1,260	1,150	1,170
1,500	1,200	1,260	1,400	1,425
2,000	1,400	1,480	1,400	1,425
2,500	1,400	1,480	1,700	1,730
3,000	1,600	1,680	1,550	1,580
3,500	1,700	1,780	1,550	1,580
4,000	1,700	1,780	1,850	1,880
5,000	1,900	1,980	1,850	1,880
6,000	2,000	2,080	1,950	1,980
7,000	2,150	2,250	1,950	1,990
8,000	2,150	2,250	2,250	2,290
10,000	2,150	2,250	2,900	2,950
12,000	2,150	2,250	3,400	3,450

Common dimensions, special dimensions and other sizes on request.

2.3 Storage and Process Tanks

Rectangular tanks

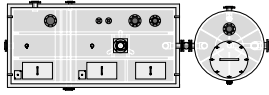
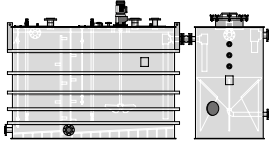

- Material polyethylene PE-HD or polypropylene PP
- Floor design, flat floor or angled floor, covering the entire area
- Roof design, flat roof or open, suitable for operation at atmospheric pressure at working temperatures of up to 60 °C
- Steel pipe reinforcement on all sides, with PE or PP jacket
- Standard equipment: 4 lifting eyes above a rectangular storage tank with a usable volume of 2000 l

Usable volume 95% fill level	Inner dimensions (L x W x H)	Outer dimensions (L x W x H)
	mm	mm
500	950 x 750 x 750	1,100 x 900 x 770
750	1,000 x 1,000 x 800	1,150 x 1,150 x 820
1,000	1,000 x 1,000 x 1,060	1,150 x 1,150 x 1,080
1,250	1,250 x 1,000 x 1,060	1,400 x 1,150 x 1,080
1,500	1,500 x 1,000 x 1,060	1,750 x 1,250 x 1,090
2,000	1,500 x 1,250 x 1,130	1,750 x 1,500 x 1,160
2,500	1,750 x 1,250 x 1,210	2,000 x 1,500 x 1,240
3,000	1,750 x 1,250 x 1,450	2,000 x 1,500 x 1,480
3,500	1,750 x 1,500 x 1,410	2,000 x 1,750 x 1,440
4,000	2,000 x 1,500 x 1,410	2,250 x 1,750 x 1,440
5,000	2,500 x 1,500 x 1,410	2,750 x 1,750 x 1,440
6,000	2,500 x 1,750 x 1,450	2,750 x 2,000 x 1,480
7,000	2,500 x 1,750 x 1,700	2,750 x 2,000 x 1,730
8,000	2,500 x 2,000 x 1,700	2,750 x 2,250 x 1,730
10,000	3,000 x 2,000 x 1,760	3,350 x 2,350 x 1,800
12,000	3,500 x 2,000 x 1,810	3,850 x 2,350 x 1,850
15,000	4,000 x 2,000 x 2,000	4,350 x 2,350 x 2,050

Common dimensions, special dimensions and other sizes on request.



3.1 Overview of Membrane Technology

Membrane filtration systems

Membrane filtration systems

In water treatment, membrane filtration is the process for removing particles and salts in the water with the lowest operating costs. ProMinent offers versatile and high-quality plant engineering in this field. This is complemented by the extensive ProMinent product range to produce customer-specific complete solutions.

Membrane filtration is a physical process to separate substances with the help of semi-permeable membranes. There are four types of processes, depending on the size of the particles/molecules to be removed:

- Microfiltration
- Ultrafiltration
- Nanofiltration
- Reverse osmosis

The following table shows the separation limits of the individual processes:

	Microfiltration	Ultrafiltration	Nanofiltration	Reverse osmosis
Particle size	> 0.1 µm	0.1 – 0.01 µm	0.01 – 0.001 µm	< 0.001 µm
Particle type	Suspended particles, colloidal turbidity, oil emulsions	Macromolecules, bacteria, cells, viruses, proteins	Low-molecular organic compounds, ions	Ions

The experts from ProMinent, with their detailed industry knowledge, are not only able to put together the optimum system for the relevant application but also deliver complete water treatment solutions from one source, supported by the extensive ProMinent product range.



3.2 Ultrafiltration Systems

3.2.1 Performance Overview of Ultrafiltration

Ultrafiltration is a membrane process which is increasingly used in water treatment to separate undesired water components. Parasites, bacteria, viruses and high-molecular organic substances as well as other particles are retained.

The applications of ultrafiltration are widespread and may include different types of water.

Typical applications include drinking water, river water, process water, swimming pool water, salt water and wastewater.

The tasks range from potable water purification to meet physical and microbiological limit values in accordance with the German Drinking Water Ordinance up to the pre-treatment of seawater for desalination by reverse osmosis.

The systems are matched to a specific task by individually selecting the membrane type and the operating mode. ProMinent uses extremely robust and resistant UF membranes and the dead-end principle to ensure optimisation with regard to investment costs, required space and operating costs. With this selection, all raw water with the exception of wastewater can be filtered largely without using chemicals.

The dead-end operation represents the standard operating mode. The raw water flows into the capillaries. The pure water (filtrate) passes through the membrane while the other constituents are retained on the surface of the membrane.

The constituents form a layer on the membrane. The membrane is backwashed fully automatically in regular intervals to remove the filter cake.

Ultrafiltration Systems Basically Consist of:

- Stainless steel or high-grade coated steel rack.
- Pre-filter to protect the membranes, if required. This filter can be designed as a backflushing filter if needed.
- UF membrane modules.
- Pneumatically controlled valves made of high-quality materials.
- Electronic pressure measurement.
- Filtration pump and backflush pump if needed with frequency converter made of suitable high-quality materials.
- Magnetically inductive flow metering to control the flow rates for filtration and backflushing.
- Integrated filling system for the backflushing water tank. The backflushing water tank is also integral to small systems. With larger systems, tanks from our product range can be integrated or an alternative application-specific solution found, depending on the customer's requirements.
- PLC with touch screen panel or microprocessor control unit. The PLC simultaneously monitors all important parameters, such as pressure, pressure difference and flow rates. This ensures that the membranes are ideally protected. The control of pre and post-treatment processes can be integrated, if required.

Advantages of Ultrafiltration Systems

- Filtrate values of less than 0.1 NTU independent of the turbidity of the raw water.
- Molecular weight cut off of the membranes (MWCO) approx. 100 kDa (kilodalton).
- Best possible retention rates for bacteria (99.9999%) and viruses (99.99% based on MS2 phages).
- Very easy to use and simple to combine with other systems owing to PLC Programmable Logic Controller with touch screen.
- Optimum operating processes due to modern measuring and control technology.
- Complete solutions with perfectly coordinated pre- and post-treatment are available on request.



3.2 Ultrafiltration Systems

Areas of Application of Ultrafiltration Systems

Typical applications include the removal of particles, turbidity and pathogens in public or private water supply. Ultrafiltration is predominantly used for the treatment of fresh water, especially surface water, spring water or well water. In principle, brackish water and seawater can also be treated, for example, as pretreatment for subsequent desalination by nanofiltration or reverse osmosis system. Other applications include the treatment of bathing water or process water from the food and beverage industry.

A typical general installation layout might be as detailed below:

- 1 Raw water
- 2 Optional pre-treatment
- 3 Pump
- 4 Filter
- 5 Module(s)
- 6 Backflushing water
- 7 Filtrate
- 8 Filtrate tank
- 9 Consumer
- 10 Post-treatment
- 11 Backflushing water tank
- 12 Metering

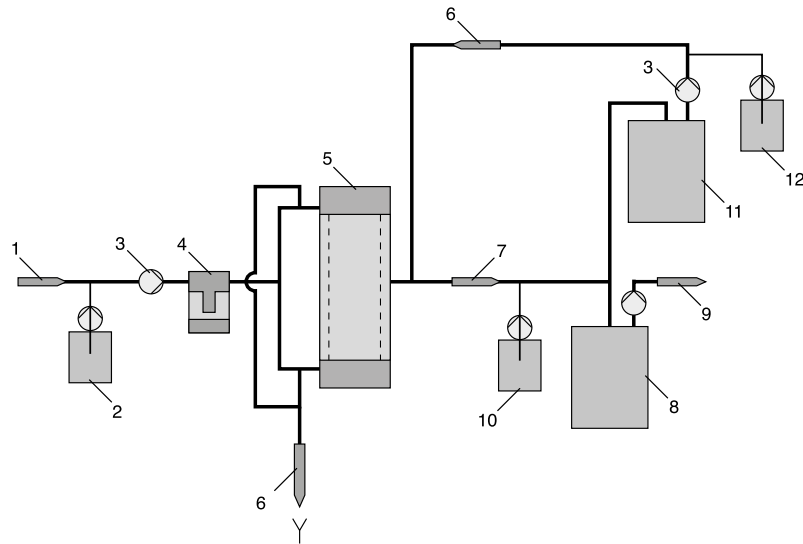

Our engineers use their wide experience in water treatment to determine the ultrafiltration system to meet the specific raw water requirements. If desired and/or required, the best-suited pre and post-treatment is also defined. Numerous further ProMinent products are available for this purpose. Thus, customers are offered a complete package of solutions from one single source.

The filtration capacity of ultrafiltration systems ranges from 1 to 80 m³/h. Other capacities are available on request. Please contact us, we will be glad to assist you.

3.2 Ultrafiltration Systems

3.2.2 Questionnaire on the Design of a UF System

- Application:**
- Drinking water production
 - Process water for food/beverage industry
 - Circulation water for swimming pools
 - Flushing water for swimming pools
 - Other: _____
- Type of raw water**
- Drinking water
 - Surface water (lake, river water)
 - Source water
 - Ground water
 - Brackish water, sea water

Design principles: (please state maximum (peak), minimum and average values)

- | | |
|--|--|
| Clear water requirement: _____ m ³ /h | Chloride: _____ ppm |
| Clear water requirement: _____ m ³ /day | Iron in solution: _____ ppm |
| Temperature: _____ °C | Particular iron: _____ ppm |
| Turbidity: _____ NTU | Manganese in solution: _____ ppm |
| COD: _____ ppm | Particular manganese: _____ ppm |
| TOC/DOC: _____ ppm | Fluctuations? Yes <input type="checkbox"/> No <input type="checkbox"/> |
| Total hardness: _____ °dH | |

Remarks (current pre-treatment, special requirements)





3.2 Ultrafiltration Systems

3.2.3 Ultrafiltration Systems DULCOCLEAN UF

Pure, crystal-clear potable water at all times

8 – 75 m³/h filtrate output



Ultrafiltration system DULCOCLEAN UF reliably and safely uses membrane technology to remove turbidity, particles and microbiological contamination.

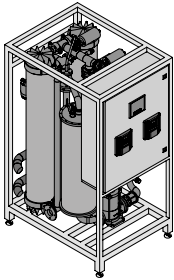

The ultrafiltration system DULCOCLEAN UF is used in water treatment to separate the finest particles and turbidity. The membranes provides a sterile barrier, so that bacteria, parasites and viruses are safely removed from the water – even with fluctuating water quality, as can occur after heavy rainfall. The quality of the filtrate remains consistently good! In potable water treatment, the filtration process is ideally used before final disinfection.

In regular cycles, back washes are performed to prevent blockages in the modules. Cleaning is supported by the addition of chemicals, where necessary, and adapted to the raw water quality present.

Your Benefits

- Very high retention rates for bacteria and viruses (based on MS2 phages) of 99.999% and/or 99.99%
- Minimal consumption of energy and water by economical dead-end operation
- Maximum operational reliability due to fully automated system control with PLC and data storage and by user-friendly touch panel with clear process visualisation
- All relevant events are recorded electronically for system optimisation and can be easily evaluated.
- Constant filtrate output and efficient back flushing by speed-controlled filtration and backwash pumps
- Complete solutions with perfectly coordinated pre and post-treatment and wastewater treatment

Technical Details

- Compact design can be installed in existing plant rooms or in a container
- Fitted with extremely resistant and shatter-proof PES ultrafiltration membranes

Field of Application

- Municipal potable water treatment: Potable water is produced from surface, spring or well water.
- Food and beverage industry: Improved water quality.
- Desalination: Pre-treatment for downstream desalination plants (RO, NF or ion exchange)

3.2 Ultrafiltration Systems

DULCOCLEAN ultrafiltration systems are suitable for use with the following water values in the feed:

pH-range	3.0...12.0
free chlorine	< 1.2 mg/l
Turbidity	0.5...30 NTU
DOC	0.5...12 mg/l
Suspended solids	50 mg/l

Deviating values influence the performance data and require a separate design of the system. Please contact our experts.

Plant	Filtrate output at 15 °C m ³ /h	Approx. backwash water per rinse m ³	Raw/rinsing water connector Rp/DN	Dimensions L x W x H mm
UF 2	8...15	0.34	1 1/2"/2"	1,200 x 920 x 2,100
UF 3	12...22.5	0.51	2"/DN 65	1,600 x 920 x 2,100
UF 4	16...30	0.68	2"/DN 80	1,600 x 920 x 2,100
UF 6	24...45	1.02	DN 65/DN 80	2,000 x 920 x 2,100
UF 8	32...60	1.36	DN 80/DN 100	2,400 x 920 x 2,100
UF 10	40...75	1.70	DN 100/DN 125	2,800 x 920 x 2,100

Systems with filtrate capacities of up to 80 m³/h are designed on a project-specific basis. Quotations are available on request. Please get in touch for more details.

Optionally available are a fully automatic neutralisation system for the treatment of acid and alkaline backwash water, an integrity test as well as customised data logging.

3.3 Nanofiltration Systems

3.3.1 Nanofiltration System DULCOSMOSE NF

Partial desalination for industrial applications - compact and cost-effective

Permeate outputs from 1 to 50 m³/h, higher outputs possible on request



As a nanofiltration system, the DULCOSMOSE NF, a compact and value-for-money unit, can handle partial desalination in industrial applications. Maximum permeate output at low operating pressures ensures low operating costs thanks to the “ultra low pressure” diaphragm.

Equipped with the latest generation of “low-pressure” membranes, this system achieves maximum permeate performance with low operating pressures and high outputs, thereby lowering investment and operating costs.

As the system runs with low operating pressures, the entire system can be fitted with inexpensive PVC pipe-work. This system is also available with an integral, semi-automated cleaning system and permeate and/or raw water flushing option.

The system can easily be adapted to meet specific customer requirements. Pipework material, other types of membrane for enhanced salt retention or discoloration, integration of measuring and control technology (such as conductivity, redox potential or pH measurement) and metering technology (in pre and post-treatment) to visualisation of the entire process with peripheral components on a PLC.

Your Benefits

- Efficient operation with a low-pressure membrane with outputs of up to 85% and high salt retention rates of up to 90% (depending on the type of membrane used).
- Reduced maintenance and service costs, as well as long membrane service lives, thanks to integrated cleaning concepts and flushing options.
- Optional permeate flushing of the entire system, including the membranes, after switching off to avoid deposits and extend the life of the membranes.
- Best ProMinent manufacturing quality: High proportion of in-house manufacturing.
- Pure quality: Use of long-life, high-quality components.
- Service-friendly construction of systems on a corrosion-resistant powder-coated steel or stainless steel frame.
- Simple and safe to operate: Microprocessor control with direct connection option for peripheral system components and integrated conductivity measurement with plain text display in the graphic display.
- One-stop shop: no interface problems, smooth running with short times between definition of the task to joint commissioning and on-site system supervision with our global subsidiaries.

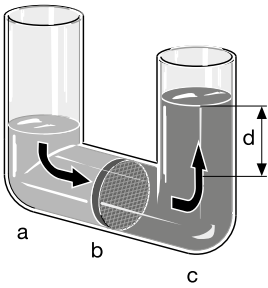

Osmosis

- a Thinned solution (permeate)
- b Semi-permeable membrane
- c Concentrated solution (concentrate)
- d Water column to match the osmotic product
- e Pressure

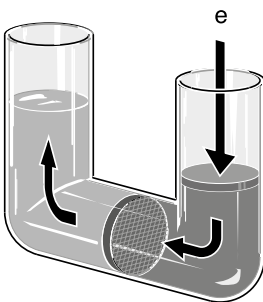

Nanofiltration

Technical Details

- Turnkey systems constructed on a high-quality, double powder-coated steel or stainless steel frame.
- Highly efficient low-pressure membranes with maximum output and system retention rates, built into epoxy-glass resin or stainless steel pressure pipes
- Pre-filter 5 µm with manometer for determining differential pressure
- Pressure switch to protect the high-pressure pump
- Flow meter to display permeate, concentrate and concentrate return volume
- Semi-automatic cleaning system for chemical module cleaning for long module service lives
- Central control for the entire system and peripheral components by the company's own microprocessor controller with graphic display and integrated temperature-compensated conductivity measurement.
- Optional permeate flushing of the entire system, including the membranes, after switching off
- 2 switching inputs for level control of the cleaning tank
- 2 switching inputs for level control of the permeate tank
- Pause switching input for external On/Off
- External fault switching input
- Temperature measuring input (Pt 100)
- Active permeate valve output (filling of cleaning tank)
- Active output for flushing valve for initial permeate disposal (depending on conductivity), raw water, permeate and interval flushing (idle time management)
- Active output for controlling a metering pump (anti-scalant)
- Analogue output 0/4...20 mA conductance
- Optional industrial PLC with touch panel and process visualisation

3.3 Nanofiltration Systems

Field of Application

- Low-cost alternative to reverse osmosis systems for special desalination tasks, such as the elimination of multiple charged ions or the removal of dyes
- Partial water softening or water softening in public drinking water
- Partial desalination in the chemical and pharmaceutical industry, food and beverage industry, metal processing industry and in electroplating

Nanofiltration is based on the same principle as reverse osmosis. The only difference is that the separation limit is slightly lower. Admittedly this type of membrane filtration retains ions dissolved in water, but to a significantly lesser extent than with reverse osmosis. Ultimately that saves operating costs.

Typical salt retention rates are around 80 – 90%. Multi-value ions (e.g. Ca and Mg) are retained better than single-value ions (e.g. Na, K) so that nanofiltration systems are often also used as an alternative to traditional water softening.

In principle with nanofiltration, the raw water to be softened is introduced into a chamber, separated by a semi-permeable diaphragm. An artificial pressure is generated in the chamber against the osmotic pressure gradient. The membrane is permeable to pure water and smaller ions. All other components of the water are retained. This produces partially softened water (permeate) and a concentrated solution (concentrate). ProMinent uses high-quality nanofiltration membranes for this process.

3.4 Reverse Osmosis Systems

3.4.1 Performance Overview of Reverse Osmosis

Reverse osmosis is a sub-sector within membrane filtration. It is the process with the highest separation limit and represents the reversal of the natural process of osmosis. It is therefore used as a method for desalinating aqueous solutions. With suitable high-performance membranes, it is possible today to remove over 99% of all salts from an aqueous solution.

In principle with reverse osmosis, the raw water to be softened is introduced into a chamber, separated by a semi-permeable membrane. An artificial pressure is generated in the chamber against the osmotic pressure gradient. As the membrane is only permeable to pure water, not to the ions and other particles dissolved in it, a proportion of pure desalinated water (permeate) and a proportion of concentrated solution (concentrate) is produced from the raw water. ProMinent uses high-quality low-pressure membranes for this process.

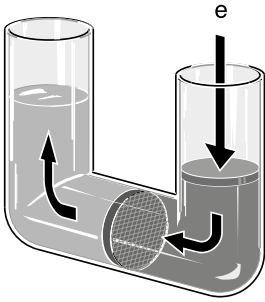

Reverse Osmosis

Basically, DULCOSMOSE Reverse Osmosis Systems Consist of:

- Stainless steel, PP or powder-coated steel frame
- 5 µm pre-filter
- High-quality inlet valve, made of appropriate materials, depending on the salt content of the raw water
- Pressure switch to protect the high-pressure pump
- High-pressure pump, made of suitable high-grade materials, depending on the salt content of the raw water
- Low-pressure membranes, designed as spiral winding modules, integrated into GRP pressure pipes
- Float flow meter and manometer
- Stainless steel control and regulating valves to regulate pressure and concentrate
- ProMinent's own conductivity sensor and reverse osmosis control with various programming options also for controlling external pre- or post-treatment components
- Semi-automatic chemical cleaning system

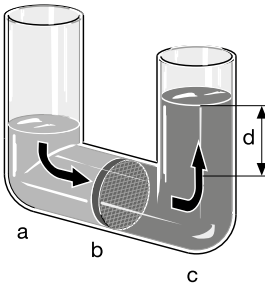

Osmosis

- a Thinned solution (permeate)
- b Semi-permeable membrane
- c Concentrated solution (concentrate)
- d Water column to match the osmotic product
- e Pressure

Advantages of DULCOSMOSE Reverse Osmosis Systems

- Simple and reliable operation thanks to modern microprocessor control with integrated conductivity measurement and plain text display of the operating status
- Efficient operation with pure water output of up to 85% and separation of more than 99% of dissolved ions
- Minimal energy consumption through the use of 'low energy' reverse osmosis membranes and energy recovery from the concentrate flow (salt water desalination)
- Long service lives of the membranes thanks to integrated cleaning concept and permeate and/or raw water flushing option
- Well thought-out, service-friendly construction of the systems on stainless steel or PP frames or made of powder-coated steel
- Minimal investment and operating costs as components are used, optimised and matched to the individual case
- On request, complete solutions with precisely coordinated pre- and post-treatment, such as ProMinent metering and measuring and control technology, i.e. simple networking, perfect operation and overall monitoring of the different components of the system

Applications of DULCOSMOSE Reverse Osmosis Systems

Typical applications include desalination work in public or private potable water supply, in the chemical and pharmaceutical industry, food and beverage industry, metal processing industry, electroplating and in the treatment of boiler feed water, for instance in power plants.

A typical general installation layout might be as detailed below:

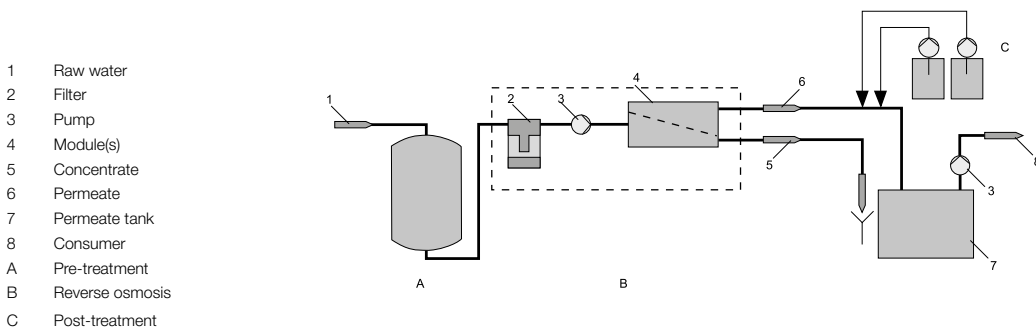

- 1 Raw water
- 2 Filter
- 3 Pump
- 4 Module(s)
- 5 Concentrate
- 6 Permeate
- 7 Permeate tank
- 8 Consumer
- A Pre-treatment
- B Reverse osmosis
- C Post-treatment



3.4 Reverse Osmosis Systems

There are basically three basic types of raw water that require desalination, each with a different salt content:

- Potable water (typically up to 1,000 mg/l)
- Brackish water (typically up to 2,000 – 5,000 mg/l)
- Sea water (typically greater than 35,000 mg/l)

Our engineers will draw on their years of experience in treating these raw waters and will evaluate the raw water analysis and identify the most suitable reverse osmosis system for you. They will also select the best-suited pre and post-treatment products from the ProMinent range, putting together a complete package from one source for the customer. Complete systems integrated in standard transport containers are one of our specialities.

ProMinent has extensive experience in the construction of other special systems, such as two-stage systems for higher permeate quality requirements. Please contact us for more details.

Type series	TW	BW	SW
Permeate output [m³h]			
50			
25			
10			
5			
2.5			
1			
0.5			
0.25			
0.1			
Salt content of feed water	< 1000 mg/l	< 5000 mg/l	< 40,000 mg/l

3





3.4 Reverse Osmosis Systems

3.4.2 Questionnaire on the Design of an RO System

Intended use of clean water: _____ m³/h
 Intended use of clean water: _____ m³/day
 Operating hours: _____ h/day
 Required clean water pressure: _____ bar
 Raw water temperature (min./max.): _____ °C

Clean water requirement:
 conductivity: _____ µS/cm
 pH value: _____

Bacteriological quality:
 Drinking Water Directive:
 Germ-free and sterile:
 Intended use of clean water:

Type of raw water:
 Drinking water
 Well water
 Brackish water
 Lake water
 or _____

Fluctuations: yes
 no

State fluctuations:

Conductivity: _____ µS/cm
 pH value: _____
 Ca: _____ mg/l
 Mg: _____ mg/l
 K: _____ mg/l
 Na: _____ mg/l
 Ba: _____ mg/l
 Sr: _____ mg/l
 Fe: _____ mg/l
 Mn: _____ mg/l
 Al: _____ mg/l

Available space (HxWxD): _____ m
 Location of the system: _____ Floor
 Location of the user: _____ Floor
 Existing clean water tank: _____ m³
 Existing clean water pump: _____ m³/h
 _____ bar
 Lift yes
 no

HxWxD: _____ mm

Door dimensions:
 HxWxD: _____ mm

Crane on site: yes
 no

Lifting capacity: _____ t

Raw water pressure: _____ bar

Raw water connection: _____

Clean water pipes available: yes
 no

Material: _____ Ø

Mains voltage: _____ V/Hz

HCO₃: _____ mg/l
 SO₄: _____ mg/l
 Cl: _____ mg/l
 NO₃: _____ mg/l
 F: _____ mg/l
 PO₄: _____ mg/l
 CO₂ (free): _____ mg/l
 SiO₂: _____ mg/l
 COD*: _____ mg/l

*COD = chemical oxygen demand

3.4 Reverse Osmosis Systems

3.4.3 Reverse Osmosis System DULCOSMOSE TW

Potable water desalination for industrial applications - compact and cost-effective

Permeate output 0.1 – 50 m³/h



Reverse osmosis system DULCOSMOSE TW is the all-purpose model for modern potable water desalination. Maximum permeate output at low operating pressures ensures low investment and operating costs.

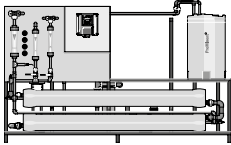

As the system runs with low operating pressures, the entire DULCOSMOSE TW can be fitted with inexpensive PVC pipework. This system is also available with an integral, semi-automated cleaning system and permeate and/or raw water flushing option. Equipped with the latest generation of 'ultra low-pressure' membranes, this system achieves maximum permeate output with low operating pressures, thereby lowering investment and operating costs.

The system is very adaptable to specific customer requirements. Pipework material, other types of membrane for enhanced salt retention, integration of measuring and control technology and metering technology to visualisation of the entire process with peripheral components via a PLC.

Your Benefits

- Efficient operation with low-pressure diaphragms with outputs of up to 90% and high salt retention rates of up to more than 99% (depending on the type of diaphragm used)
- Reduced maintenance and service costs as well as long diaphragm service lives, thanks to integrated cleaning concepts and flushing options, such as permeate flushing
- Service-friendly construction of systems on a corrosion-resistant powder-coated steel, stainless steel frame or PP frame
- Simple and safe to operate: Control with direct connection option for peripheral system components and integrated conductivity measurement with plain text display in the graphic display
- One-stop shop: no interface problems, smooth running with short times between definition of the task to joint commissioning and on-site system supervision with our global subsidiaries.

Technical Details

- Turnkey systems constructed on a high-quality, double powder-coated steel or stainless steel frame
- Highly efficient low-pressure membranes with maximum output and system retention rates of over 99% integrated in epoxy-glass resin pressure pipes
- Pre-filter 5µm with manometer for determining differential pressure
- Pressure switch to protect the high-pressure pump
- Flow meter to display permeate, concentrate and concentrate return volume
- Semi-automatic cleaning system for chemical module cleaning for long module service lives
- 2 switching inputs for level control of the cleaning tank
- 2 switching inputs for level control of the permeate tank
- Pause switching input for external On/Off
- External fault switching input
- Temperature measuring input (PT 100)
- Active permeate valve output (filling of cleaning tank)
- Active output for flushing valve for initial permeate disposal (depending on conductivity), raw water, permeate and interval flushing (idle time management)
- Active output for controlling a metering pump (anti-scalant)
- Analogue output 0/4...20 mA conductance
- Optional industrial PLC with touch panel and process visualisation

Field of Application

- Power plants: Provision of boiler feed water
- Electroplating/metal processing industry: Provision of rinsing water
- Beverage industry: Provision of rinsing water, product water and process and return dilution water
- Food industry: Provision of rinsing water and process water
- Chemical industry: Provision of rinsing water and process water
- Provision of rinsing water and process water for laboratory purposes and industrial rinsing machines
- Pure water for laboratory applications, hospital uses (autoclaves, high-speed steam generators)
- Feed water for cooling and air conditioning plants (air humidification and air scrubbers)
- Process water in printing plants, the pharmaceutical or cosmetics industry



3.4 Reverse Osmosis Systems

Technical data

The product range DULCOSMOSE TW was designed for the following values in feed water:

Max. salt content PRO 0010TW – 0055TW*	650 mg/l
Max. salt content PRO 0060TW – 5000TW*	1,000 mg/l
pH-range	3.0...10.0
Silt density index max.	3
Free chlorine max.	0.1 mg/l
Total Fe, Mn max.	0.2 mg/l
Total hardness max.	0.1 °dH
Bacteria count max.	100 KBE/ml
Turbidity max.	0.5 NTU
COD max.**	5 mg/l

* Different salt content influences the performance data accordingly

** as O₂

Systems with 2.5 or 4" membranes, system salt retention 90-97%

Plant	Permeate capacity at 15 °C water temperature l/h	Number of 2.5" and 4" membranes	Connected load kW	Dimensions H x W x D mm	Order no.
		No.			
PRO 0010TW	100	1	0.37	1,400 x 500 x 320	1104535
PRO 0020TW	200	2	0.55	1,400 x 500 x 320	1104536
PRO 0030TW	300	1	1.10	1,500 x 600 x 400	1104537
PRO 0055TW	550	2	1.10	1,500 x 600 x 400	1104539
PRO 0060TW	600	2	1.50	1,650 x 700 x 720	1104540
PRO 0090TW	900	3	1.50	1,650 x 700 x 720	1104541
PRO 0120TW	1200	4	1.50	1,650 x 700 x 720	1104542
PRO 0150TW	1500	5	2.20	1,650 x 700 x 720	1104543
PRO 0180TW	1800	6	2.20	1,750 x 2,600 x 750	1106338
PRO 0240TW	2400	8	3.00	1,750 x 2,600 x 750	1106340
PRO 0270TW	2700	9	3.00	1,750 x 3,500 x 750	1106342

Systems with 8" membranes, system salt retention 90-97%

Plant	Permeate capacity at 15 °C water temperature l/h	Number of 8" membranes	Connected load kW	Dimensions H x W x D mm	Order no.
		No.			
PRO 0300TW	3000	3	3.0	1,800 x 4,000 x 1,000	on request
PRO 0400TW	4000	4	3.0	1,800 x 3,000 x 1,000	on request
PRO 0500TW	5000	5	4.0	1,800 x 4,000 x 1,000	on request
PRO 0600TW	6000	6	4.0	1,800 x 4,000 x 1,000	on request
PRO 0700TW	7000	6	5.5	1,800 x 4,000 x 1,000	on request
PRO 0800TW	8000	7	5.5	1,800 x 4,000 x 1,000	on request
PRO 0900TW	9000	7	7.5	1,800 x 4,000 x 1,000	on request
PRO 1000TW	10000	8	11.0	1,800 x 3,000 x 1,000	on request
PRO 1100TW	11000	9	11.0	1,800 x 4,000 x 1,000	on request
PRO 1200TW	12000	10	11.0	1,800 x 4,000 x 1,000	on request
PRO 1300TW	13000	11	11.0	1,800 x 4,000 x 1,000	on request
PRO 1400TW	14000	12	11.0	1,800 x 4,000 x 1,000	on request
PRO 1500TW	15000	12	11.0	1,800 x 4,000 x 1,000	on request
PRO 2000TW	20000	18	11.0	1,800 x 7,000 x 1,200	on request
PRO 2500TW	25000	24	15.0	1,800 x 7,000 x 1,200	on request
PRO 3000TW	30000	28	18.5	1,800 x 7,000 x 1,200	on request
PRO 4000TW	40000	34	22.0	1,800 x 7,000 x 1,200	on request
PRO 5000TW	50000	48	22.0	1,800 x 7,000 x 1,200	on request

On request, these systems can also be supplied with other membrane types for greater salt retention and measuring and control technology (conductivity, redox potential, pH measurement) and metering technology (in pre and post-treatment).

3.4 Reverse Osmosis Systems

3.4.4 Reverse Osmosis System DULCOSMOSE BW

Brackish water is transformed into potable water

Permeate output 2,000 – 50,000 l/h



Reverse osmosis system DULCOSMOSE BW is the standard model for the modern desalination of brackish water. Equipped with the latest generation of 'high rejection low-pressure' membranes, this system achieves maximum permeate output with moderate operating pressures, thereby lowering investment and operating costs.

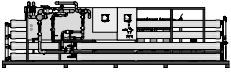

A reverse osmosis system of type BW has PVC pipework on the low-pressure side. The system has high-grade stainless steel (type DIN 1.4571) on the high-pressure side. Stainless steel pipes are welded under shielding gas and a forming gas atmosphere and subsequently passivated in a pickling bath. The integrated semi-automatic cleaning system with permeate and/or raw water flushing ensures exceptionally long membrane service lives, as scaling and fouling effects are minimised. The system is very adaptable to specific customer requirements. Pipework material, other types of membrane for enhanced salt retention, integration of measuring and control technology and metering technology to visualisation of the entire process with peripheral components via a PLC.

Your Benefits

- Efficient operation with low-pressure membranes with maximum output and salt retention rates of up to over 99 %
- Reduced maintenance and service costs as well as long membrane service lives, thanks to integrated cleaning concepts and flushing options
- Service-friendly construction of systems on a corrosion-resistant powder-coated steel or stainless steel frame
- Simple and safe to operate: Central control of the entire system by microprocessor controller or industrial PLC with touch panel and process visualisation.
- Application-optimised design taking into account economic aspects, such as the durability of the membranes, energy efficiency and process automation
- One-stop shop: No interface problems, smooth running with short times between definition of the task to joint commissioning and on-site system supervision with our global subsidiaries

Technical Details

- Turnkey systems constructed on a high-quality, double powder-coated steel or stainless steel frame.
- Highly efficient low-pressure membranes with maximum output and system retention rates of over 99% integrated in epoxy-glass resin pressure pipes
- Pre-filter 5µm with manometer for determining differential pressure
- Pressure switch to protect the high-pressure pump
- Flow meter to display permeate, concentrate and concentrate return volume
- Semi-automatic cleaning system for chemical module cleaning for long module service lives
- 2 switching inputs for level control of the cleaning tank
- 2 switching inputs for level control of the permeate tank
- Pause switching input for external On/Off
- External fault switching input
- Temperature measuring input (Pt 100)
- Active permeate valve output (filling of cleaning tank)
- Active output for flushing valve for initial permeate disposal (depending on conductivity), raw water, permeate and interval flushing (idle time management)
- Active output for controlling a metering pump (anti-scalant)
- Analogue output 0/4...20 mA conductance
- Optional industrial PLC with touch panel and process visualisation

Field of Application

- Decentralised, public or private supply of potable water.

3.4 Reverse Osmosis Systems

The product range DULCOSMOSE BW was designed for the following values in feed water:

Salt content max.*	5,000 mg/l
pH-range	3.0...10.0
Silt density index max.	3
Free chlorine max.	0.1 mg/l
Total Fe, Mn max.	0.2 mg/l
Max total hardness	water must be chemically stabilised
Bacteria count max.	100 KBE/ml
Turbidity max.	0.5 NTU
COD max.**	5 mg/l

* Different salt content influences the performance data accordingly

** as O₂

Systems with 8" membranes, system salt retention 95-99%

Plant	Permeate capacity at 25 °C water temperature l/h	Number of 4" and 8" membranes No.	Connected load kW	Dimensions H x W x D mm
PRO 0200BW	2000	9	4.0	1,800 x 3,500 x 750
PRO 0300BW	3000	3	5.5	1,800 x 4,000 x 1,000
PRO 0400BW	4000	4	5.5	1,800 x 3,000 x 1,000
PRO 0500BW	5000	5	5.5	1,800 x 4,000 x 1,000
PRO 0600BW	6000	6	7.5	1,800 x 4,000 x 1,000
PRO 0700BW	7000	7	7.5	1,800 x 4,000 x 1,000
PRO 0800BW	8000	8	15.0	1,800 x 4,000 x 1,000
PRO 0900BW	9000	9	15.0	1,800 x 4,000 x 1,000
PRO 1000BW	10000	10	15.0	1,800 x 4,000 x 1,000
PRO 1100BW	11000	11	15.0	1,800 x 4,000 x 1,000
PRO 1200BW	12000	12	15.0	1,800 x 5,000 x 1,000
PRO 1300BW	13000	13	15.0	1,800 x 6,000 x 1,000
PRO 1400BW	14000	14	15.0	1,800 x 5,000 x 1,000
PRO 1500BW	15000	15	18.5	1,800 x 5,000 x 1,000
PRO 2000BW	20000	21	18.5	1,800 x 6,000 x 1,200
PRO 2500BW	25000	26	30.0	1,800 x 6,000 x 1,200 *
PRO 3000BW	30000	29	30.0	1,800 x 6,000 x 1,200 *
PRO 4000BW	40000	42	45.0	1,800 x 7,000 x 1,200 *
PRO 5000BW	50000	51	60.0	1,800 x 7,000 x 1,200 *

* Separate cleaning tank

On request, these systems can also be supplied with other membrane types for greater salt retention and measuring and control technology (conductivity, redox potential, pH measurement) and metering technology (in pre and post-treatment).



3.4 Reverse Osmosis Systems

3.4.5

Reverse Osmosis System DULCOSMOSE SW

Salt water is transformed into drinking water.

Permeate output 780 – 29,000 l/h



The reverse osmosis system DULCOSMOSE SW is the standard model for modern desalination of salt water. Equipped with the latest generation of 'high rejection low-pressure' membranes, this system achieves maximum permeate output with moderate operating pressures, thereby lowering investment and operating costs.



A reverse osmosis system of type of SW has PVC pipework on the low-pressure side. The high-pressure side of the system has a potable water-compatible, highly corrosion-resistant inner seal due to the high NaCl content. The integrated semi-automatic cleaning system with permeate and/or raw water flushing ensures exceptionally long membrane service lives, as scaling and fouling effects are minimised. The system can be adapted with ease to specific customer requirements. Pipework material, other types of membrane for enhanced salt retention, integration of measuring and control technology and metering technology to visualisation of the entire process with peripheral components via a PLC. Everything can be selected at random. Optional for all systems: They can be fitted with a system for energy recovery from the concentrate flow. The latest generation of what are known as pressure controllers is used.

Your Benefits

- Integrated energy recovery system based on state-of-the-art pressure controllers
- Efficient operation with low-pressure membranes with outputs of up to 50% and high salt retention rates of up to over 99%
- Reduced maintenance and service costs as well as long membrane service lives, thanks to integrated cleaning concepts and flushing options
- Service-friendly construction of systems on a corrosion-resistant powder-coated steel or stainless steel frame
- Simple and safe to operate: Central control of the entire system by microprocessor controller or industrial PLC with touch panel and process visualisation
- Application-optimised design taking into account economic aspects, such as the durability of the membranes, energy efficiency and process automation
- One-stop shop: No interface problems, smooth running with short times between definition of the task to joint commissioning and on-site system supervision with our global subsidiaries

Technical Details

- Turnkey systems constructed on a high-quality, double powder-coated steel or stainless steel frame
- Highly efficient low-pressure membranes with maximum output and system retention rates of over 99% integrated in epoxy-glass resin pressure pipes
- Pre-filter 5µm with manometer for determining differential pressure
- Pressure switch to protect the high-pressure pump
- Flow meter to display permeate and concentrate volume
- Semi-automatic cleaning system for chemical module cleaning for long module service lives
- Central PLC of the entire system and peripheral components, adapted to customer requirements

Field of Application

- Decentralised, public or private supply of potable water.

3.4 Reverse Osmosis Systems

The product range DULCOSMOSE SW was designed for the following values in feed water:

Salt content max.*	40.000 mg/l
pH-range	3.0...10.0
Silt density index max.	3
Free chlorine max.	0.1 mg/l
Total Fe, Mn max.	0.2 mg/l
Max total hardness	water must be chemically stabilised
Bacteria count max.	100 KBE/ml
Turbidity max.	0.5 NTU
COD max.**	5 mg/l

* Different salt content influences the performance data accordingly

** as O₂

Plants with 4" and 8" membranes, salt rejection of the plants 99%

Plant	Permeate capacity at 25 °C water temperature l/h	Number of 4" and 8" membranes No.	Connected load without energy recovery kW	Connected load with energy reco- very* kW	Dimensions H x W x D mm
PRO 0078SW	780	6	5.5	-	1,800 x 3,500 x 1,000
PRO 0185SW	1850	3	11.0	-	1,800 x 4,000 x 1,000
PRO 0240SW	2400	4	15.0	-	1,800 x 4,000 x 1,000
PRO 0300SW	3000	5	18.5	11.2	1,800 x 4,000 x 1,000
PRO 0360SW	3600	6	18.5	14.7	1,800 x 4,000 x 1,000
PRO 0490SW	4900	8	30.0	20.5	1,800 x 5,000 x 1,200
PRO 0610SW	6100	10	37.0	20.5	1,800 x 6,000 x 1,200
PRO 0730SW	7300	12	41.0	24.0	1,800 x 5,000 x 1,400
PRO 0920SW	9200	15	75.0	27.5	1,800 x 6,000 x 1,500
PRO 0980SW	9800	16	75.0	35.5	1,800 x 5,000 x 1,500
PRO 1230SW	12300	20	75.0	35.5	1,800 x 6,000 x 1,500 **
PRO 1470SW	14700	24	90.0	41.0	1,800 x 7,000 x 1,500 **
PRO 1840SW	18400	30	110.0	56.0	1,800 x 7,000 x 1,500 **
PRO 2210SW	22100	36	132.0	66.0	1,800 x 7,000 x 1,500 **
PRO 2580SW	25800	42	150.0	66.0	1,800 x 7,000 x 1,500 **
PRO 2900SW	29000	48	180.0	90.0	1,800 x 7,000 x 1,500 **

* Pressure converter for energy recovery

** Separate cleaning tank

On request, these systems can also be supplied with other membrane types for greater salt retention and measuring and control technology (conductivity, redox potential, pH measurement) and metering technology (in pre and post-treatment).



4.1 DULCONNEX: IIoT Solution for Digital Fluid Management

4.1.1 Smart Process Monitoring – Any time, Anywhere



Improved process safety, reliability and transparency due to real-time monitoring, individual alarms and automated reports.



ProMinent's DULCONNEX is the cloud-based IIoT solution for digitally networking your system components. The solution consists of individual solution modules, which can be combined specifically to meet customer requirements:

	Pricing logic	Order no.
DULCONNEX Gateway AGIb	One-time price	1098723
DULCONNEX Gateway DACb	One-time price	1098756
DULCONNEX Gateway pumps and I/O modules	One-time price	1105889
DULCONNEX Gateway UVCb, CDLb	One-time price	1098757
CAN connection kit UVCb	One-time price	1098757
DULCONNEX Blue	Free app (Google Play Store / Apple App Store)	-
DULCONNEX Platform	Monthly fee per connected device	1039138
DULCONNEX Inventory Management	Monthly fee per connected Inventory Management-enabled device	DX000004
DULCONNEX API	Monthly fee per connected device	1110567

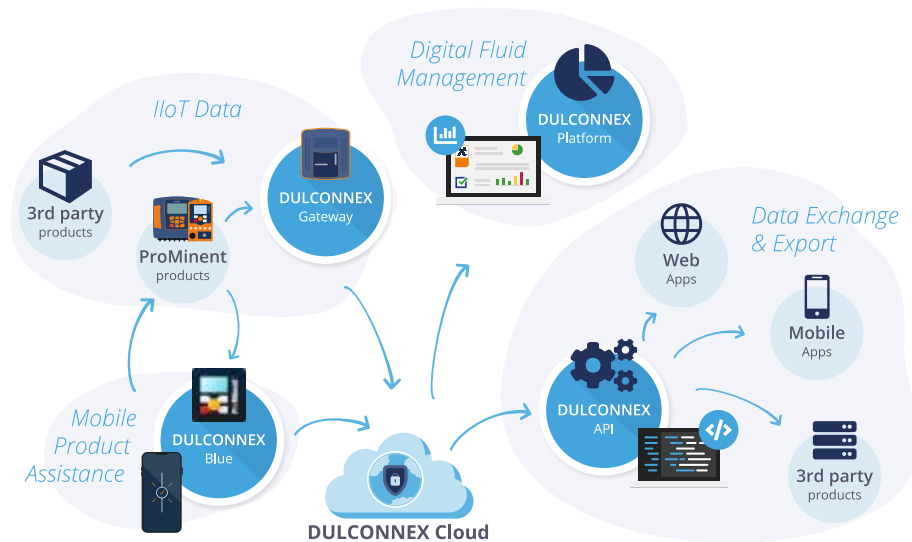

The DULCONNEX Cloud lies at the heart of the DULCONNEX solution. It meets stringent safety standards, receives data from connected devices and makes this data available to target applications, such as the DULCONNEX Platform. A DULCONNEX Gateway is needed to integrate both ProMinent products as well as third-party products into the cloud.

Using the DULCONNEX Blue app, our digital wizard, ProMinent products can also be connected to the user's mobile via a Bluetooth connection without connecting to the cloud, greatly simplifying user interactions.

On the basis of data available in the cloud, external services can be fed data via API.

Location-independent system monitoring in real time

With DULCONNEX, you always have access to all the key data and measured values for your pump installations. Monitor the status of your system in real time and benefit from continuous documentation. Check your device data safely and reliably when you're out and about. Simply use the terminal device of your choice: smartphone, tablet or PC. Configurable alarms and notifications inform you of relevant events 24/7.

Be in a position to act promptly at all times with DULCONNEX. No matter whether you work with industrial and process water, cooling water, potable water or swimming pool water – DULCONNEX supports you in ensuring the reliable treatment of your fluids.

4.1 DULCONNEX: IIoT Solution for Digital Fluid Management

4.1.2 Reference Waterworks

The aim of water treatment is the removal of potentially hazardous substances from the water and, at the same time, the addition of substances for purifying purposes. Our metering pumps and measuring and control systems enable the addition of chlorine, chlorine dioxide, ozone and flocculants, etc. to the water circuit. DULCONNEX enables you to view all the key parameters such as pH, chlorine and ozone content or conductivity, at any time and from anywhere.

DULCONNEX also continuously logs the operating parameters of all connected components and makes them available to you in the form of value diagrams and summarised reports to ensure that you always retain an overview of your processes.

You can use individually configurable alarms to define key limit values, which may not be exceeded or undershot, ensuring that you are immediately informed in the event of a fault. This enables you to easily ensure, among other things, that the radiation intensity of your UV system is sufficient, that all metering pumps have metered correctly and that the measured water parameters meet all requirements.



4.1 DULCONNEX: IIoT Solution for Digital Fluid Management

4.1.3

Reference Hotel

Many factors are decisive for economic and hence successful operation of a hotel – one of them is clean and germ-free drinking water.

Disinfection with chlorine dioxide offers a range of different benefits. Chlorine dioxide degrades biofilms in pipework and tanks, protecting your system against legionella attack. It also has a sustained-release effect due to its long-term stability in the piping system. Our chlorine dioxide systems also provide for disinfection independent of the pH value.

Connecting your disinfection systems and controllers to DULCONNEX also provides you with automatic and continuous documentation of the process data recorded. This enables you to log the hygiene-compliant operation of your systems, therefore conforming to the relevant regulations without the risk of tampering.

You can use individually configurable alarms to define key limit values, which may not be exceeded or under-shot, ensuring that you are immediately informed in the event of a fault and do not need to keep checking on your devices in the interim.

That way, DULCONNEX helps you achieve smooth and carefree water treatment in your hotels.

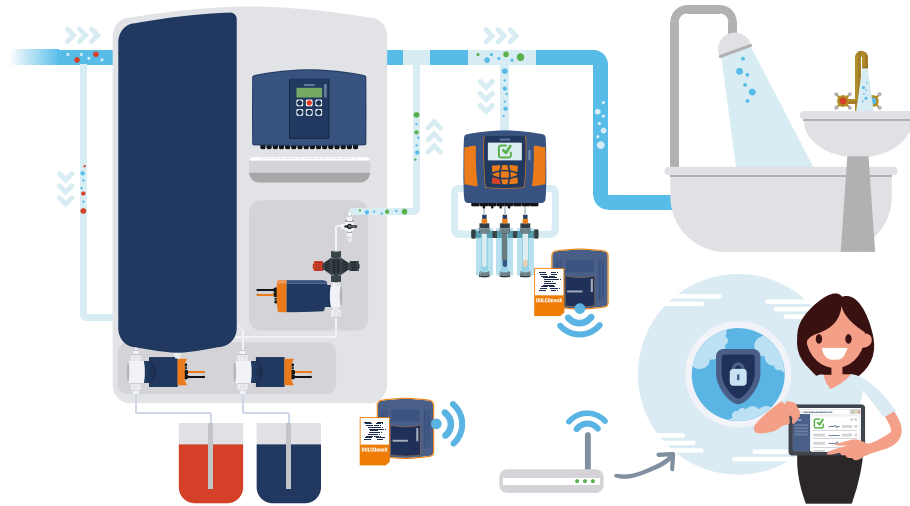

4.1 DULCONNEX: IIoT Solution for Digital Fluid Management

4.1.4 Your Benefits of Digital Fluid Management



- **Complete overview of all your devices and installations** – any time and from anywhere.
- **Reliable saving of your complete value history** including alarms and warnings that occur.
- **Individual alarms by e-mail** – Keep up to date at all times.
- **Continuous logging and automatic reports** – Documentation and evidence of correct operation.
- **Clear visualisation** – Graphic display of value and parameter combinations.
- **Access via the web** – Simply use any of your smart devices with an installed browser. You do not need an additional app nor a permanent link to the connected device.

The DULCONNEX Platform can be accessed at <https://dulconnex.prominent.com>. Please contact us for free access to try out the solution and send us your questions.

Privacy and data security



The architecture of DULCONNEX is already designed to achieve maximum safety and reliably protect your data. For example, there is a systematic separation of user-specific data and measured values. In addition, all measured values are anonymised internally and the entire system is regularly inspected by professional IT safety service providers for possible safety gaps.

Examples of relevant safety measures:

- Encryption in accordance with the latest state of the art
- Multiple redundant data memories
- Systematic control of the equipment ownership

Constantly growing portfolio of supported products

- **Pumps**
 - gamma/ X
 - gamma/ XL
 - DULCOFLEX DFXa
 - DULCOFLEX DFYa
 - sigma/ X
 - DULCOFLEX DF4a
- **Controller**
 - DULCOMETER diaLog DACb
 - AEGIS II
 - SlimFLEX 5a
- **Radar sensor DULCOLEVEL**
- **Water treatment and disinfection systems**
 - UV systems DULCODES MP, LP/LP certified/LP F&B/LP-PE
 - Chlorine dioxide systems Bello Zon CDLb, CDKd and CDVd
 - Electrolysis system CHLORINSITU IIa 60–2500 g/h
- **Industrial standard signals via dedicated I/O modules**
 - Digital inputs (relays, with counters too)
 - Analogue inputs (4...20 mA)

4.1 DULCONNEX: IIoT Solution for Digital Fluid Management

4.1.5 DULCONNEX Gateway

Secure and reliable provision of IIoT data



The DULCONNEX Gateway safely and reliably transfers the data of all products supported as standard to the DULCONNEX Cloud



Our DULCONNEX Gateway enables all smart products to be connected to our web-based fluid management platform.

Using a gateway matched to the relevant product guarantees smooth and reliable operation. The customer must provide a WiFi access point with an internet connection in order to communicate with the DULCONNEX Platform.

	Suitable for system types	Order no.
DULCONNEX Gateway AGIb	AEGIS II	1098723
DULCONNEX Gateway DACb	DULCOMETER diaLog DACb	1098756
DULCONNEX Gateway pumps and I/O modules	gamma/ X, gamma/ XL, delta, DULCOFLEX DF4a, DULCOFLEX DFXa, DULCOFLEX DFYa, I- and M-modules (DULCOMARIN II), Frenzel+Berg modules (CIO50, CIO57, CIO58, CIO60, CIO300), Sigma X	1105889
DULCONNEX Gateway UVCb, CDLb	DULCODES LP/MP, chlorine dioxide systems Bello Zon CDLb	1098757

4.1 DULCONNEX: IIoT Solution for Digital Fluid Management

4.1.6

DULCONNEX Blue

Efficient and safe operation of pumps by smartphone

Mobile app for Android and iOS



The next generation of mobile product assistance from ProMinent – DULCONNEX Blue. The smart app enables intelligent pumps to be conveniently controlled by Bluetooth.



Your Benefits

- Easy operation and configuration of gamma/ X pumps in installation environments that are hard to access
- Live monitoring of device status and performance data from a safe distance
- Reliable remote control of supported ProMinent products
- User-friendly operation by means of intuitive interface and multilingual displays
- Efficient commissioning by simply copying of the configuration from one pump to other pumps
- Obtain professional support quickly in an emergency case – generate error logs at the press of a button and share them directly with service personnel

Technical Details

Key functions

- **Secure communication** – Simple authentication and coupling with supported devices for secure data exchange by Bluetooth interface.
- **Reliable remote control** – Simply operate ProMinent devices in hard-to-reach installation environments by means of secure remote control.
- **Intuitive design** – Pumps can now be operated even more conveniently thanks to the modern and multilingual user interface.
- **Always up to date** – The key information from all devices can be gathered at a glance on the clearly arranged dashboard. Information on current device status and performance data, as well as firmware updates, are available at any time.
- **Simple pump configuration** – Restore saved device configurations at any time and copy them quickly from one pump to others.
- **End-to-end documentation** – Automatic recording of key operating data in the log book and the integrated commissioning report help to comply with regulatory documentation obligations.
- **Direct access to product documentation** – Permanent access to the latest version of product-specific documents or relevant files.

Technical requirements

- Supported model with the latest firmware version
- Built-in Bluetooth module (Bluetooth Classic or Bluetooth Low Energy)
- Mobile end device with supported operating system (Android from version 9.0 (“Pie”) or later and iOS from version 12 or later)

Supported devices

- Solenoid-driven metering pump gamma/ X and gamma/ XL with Bluetooth Classic module from firmware version: 02.05.06.02 or later with Bluetooth Low Energy module from firmware version: 02.06.01.01 or later
- Radar liquid level sensor DULCOLEVEL

Further modules will continue to be released in the future.

Supported languages

- German (DE)
- English (EN)
- French (FR)
- Spanish (ES)
- Polish (PL)

4.1 DULCONNEX: IIoT Solution for Digital Fluid Management

Availability

- Apple App Store for mobile devices with iOS operating system (iPhone/iPad)
- Google Play Store for Android devices

Field of Application

- **Enhanced safety for personnel and processes** – Adapt the settings of connected devices directly or control the pump capacity and metering volume from a safe distance without having to put on protective equipment in advance. The opportunity to simply save device configurations and reset them to earlier statuses at any time provides for additional safety.
- **Commissioning in record time** – Significant time saved particularly when setting up multiple devices by transmitting the configuration of one pump to other pumps.
- **Everything under control** – Keep an eye on the statuses and performance data of connected pumps at all times, thanks to the clearly laid out dashboard. Access real-time operating data, including dosing rate, liquid level and system pressure, and make changes immediately if you need to.
- **Minimise downtimes** – The device automatically generates a logbook with all errors, warnings and events that have occurred. Detailed error logs can be generated at the press of a button, which can be shared quickly and easily with local service personnel. This guarantees the fastest possible help in an emergency to avoid long downtimes.
- **Provision of evidence** – The built-in commissioning report provides straightforward evidence of the set-up and commissioning of systems. Automatic recording of key operating data, including the current feed rate or number of strokes, simplifies compliance with regulatory documentation obligations.

4.1 DULCONNEX: IIoT Solution for Digital Fluid Management

4.1.7

DULCONNEX Platform

Location-independent monitoring and documentation of system and process data

Web-based IIoT platform for digital fluid management



DULCONNEX Platform is a web-based IIoT platform for digital fluid management. The web application offers simple and location-independent access to all relevant system and process data and thus increases system availability. By continuously monitoring important parameters, the process quality can be optimized and the safety of employees increased. Comprehensive logging and automated generation of reports facilitate the fulfilment of documentation obligations.



Your Benefits

- **Always one step ahead of events** - keep an eye on the status and functionality of systems at all times and react in good time thanks to configurable alarms with e-mail notification function. In an emergency, easily create and share documentation in order to receive competent help as quickly as possible.
- **A plus in transparency and security** - Gaining knowledge of the exact process and system status on-site even before entering potentially dangerous environments. The complete history of all measured values and system data as well as their reliable storage in the cloud also offer additional protection against manipulation and data loss.
- **Plan service assignments more efficiently and prepare them more effectively** - With the help of location-independent access to status and performance data, journeys for pure inspection and documentation purposes can be minimized. Knowledge of the exact system status before arrival at the place of use also enables service activities to be optimally prepared.
- **Increased system availability and optimized process quality** - The visualization of freely combinable parameters in diagrams allows detailed analysis of processes and supports the identification of optimization potential.
- **Easier fulfilment of regulatory documentation obligations** - Thanks to continuous logging, automated generation of reports and the simple export function, the manual effort required to provide evidence of proper operation is significantly reduced.

Technical Details

The responsive design and the intuitive user interface of the web application ensure that users benefit quickly and easily from the numerous functions of the IIoT platform:

- **Dashboards** - The most important information from various systems or process sections can be seen at a glance on individually configurable dashboards
- **Alarms** - Freely configurable alarm messages by e-mail inform about exceeding or falling below individually adjustable limit values and about other important events
- **Log book** - The continuous logging of all system data and events creates increased transparency and additional security
- **Data history** - A complete history of operating data and measured values supports operators in fulfilling regulatory documentation obligations and forms the basis for comprehensive analyzes
- **Visualization** - Both current and historical measured values can be freely combined in diagrams, which facilitate detailed analyzes of system performance and process quality
- **Reports** - With the help of the automated report generation and the simple creation of individual documentation in exportable file formats, proof of proper operation is possible with minimal effort.

4.1 DULCONNEX: IIoT Solution for Digital Fluid Management

Field of Application

- **Increase transparency** - Regardless of whether it is pumps, controllers, sensors or systems, the current status and performance data are retrieved from all installation locations in real-time and stored securely in the DULCONNEX cloud. With the help of the DULCONNEX Platform, operators have access to the complete history of their process data at any time and from anywhere and can effortlessly keep an eye on critical measured values such as dosing rate, fill level or system pressure.
- **Ensure system availability** - Comprehensive logging of the device status, including all errors, warnings and events, pays off, especially in time-critical situations. Detailed documentation can be generated at the push of a button, which can be quickly and easily shared with local service contacts. This guarantees the fastest possible help in an emergency and minimizes the risk of longer downtimes.
- **Optimize processes** - Current fill levels can be clearly displayed on the individually designed dashboards and reliably monitored with the help of configurable alarms. Upon request, automated notifications inform the responsible employees or chemical suppliers when critical limit values are reached so that they can provide replenishment in good time. Process-critical chemicals can thus be delivered and stocked with pinpoint accuracy.
- **Protect employees** - Via the DULCONNEX Platform, operators, employees or service technicians gain knowledge of the exact process and system status on-site even before entering potentially dangerous environments. In this way, every operation can be optimally prepared and safety increased.
- **Prove conformity** - The continuous logging of all relevant operating data facilitates the fulfilment of regulatory documentation obligations. By means of automatically generated reports, manual work is significantly reduced and the proper operation of systems can be easily verified at any time.

	Pricing logic	Order no.
DULCONNEX Platform	Monthly fee per connected device	1039138

4.1 DULCONNEX: IIoT Solution for Digital Fluid Management

4.1.8 DULCONNEX Inventory Management

The ideal DULCONNEX extension for your tank level application



The DULCONNEX Inventory Management add-on is an extension to the DULCONNEX Platform. It can be used to monitor tank levels and inventory levels of chemicals at various sites regardless of your location. Tank level monitoring is based on the data of the DULCOLEVEL radar level sensor.

The DULCONNEX Inventory Management add-on is an extension to the DULCONNEX Platform. It can be used to monitor tank levels and inventory levels of chemicals at various sites regardless of your location.

It also provides specific dashboards, reports and views to allow you to use your tank level application as efficiently as possible.



- Simple integration of existing or new tank level applications
- Detailed overview of all elements of the application, such as tank levels with warning levels, inventory levels, chemicals and locations
- Geographic overview of all systems with colour visualisation of tank levels and inventory levels
- Specific reports for tank level applications such as a detailed usage certificate for compliance with specifications

	Pricing logic	Order no.
DULCONNEX Inventory Management	Monthly fee per connected Inventory Management-enabled device	DX000004

4.1 DULCONNEX: IIoT Solution for Digital Fluid Management

4.1.9 DULCONNEX API

Integrate the raw data from your application into any system of your choice



With DULCONNEX API, you can access your data on request from the DULCONNEX Cloud. Use this for integration into existing process control systems, SCADA, mobile or online apps as well as MES or share data with other digital solutions.



Your Benefits

- Simple integration of existing or new tank level applications
- Detailed overview of all elements of the application, such as tank levels with warning levels, inventory levels, chemicals and locations
- Geographic overview of all systems with colour visualisation of tank levels and inventory levels
- Specific reports for tank level applications such as a detailed usage certificate for compliance with specifications

Technical Details

The responsive design and intuitive user interface of the web application ensure that users quickly and easily benefit from the numerous functions of the Inventory Management module in the IIoT platform:

Dashboard – The Inventory Management dashboard helps to provide a clear view of all key information, such as designation, location, current liquid level, critical classification of the liquid level, remaining tank range, chemicals as well as associated inventory levels for all tank level applications.

List view – The list view allows all tank level applications to be displayed grouped in one complete overview or by location. Inventory levels, tanks, locations and complete tank level applications can be managed within these views. In addition, detailed filters can be used to align the view to the user's needs.

Map – The overview map features colour indicators and so can be used to quickly and easily view all liquid and inventory levels. More detailed information can be displayed by selecting a location.

Inventory report – All inventory movements of the chemicals can be provided in PDF or Excel format for the desired time period, allowing transparency to be improved and documentation to be simplified.

Consumption report – All consumption of chemicals for each location and the total consumption of a chemical is documented in PDF or Excel format when using this report. The data is provided accurate to the day, ensuring a high level of traceability.

Compliance report – When using certain chemicals, this report helps you to comply with regulations as it generates a usage certificate per device.

	Pricing logic	Order no.
DULCONNEX API	Monthly fee per connected device	1110567

Your digital reference source.
Wherever you want. Whenever you want.

Product Catalogue 2024

Groundbreaking diversity: ProMinent 2024.
Our product catalogue is available in three individual volumes.



Metering Technology



Measuring, Control and Sensor Technology



Water Treatment and Disinfection

You can find our individual catalogue volumes for download or online browsing at
www.prominent.com/en/product-catalogue

Do you need an overview of our entire product range?
Then we would recommend our product overview.
www.prominent.com/en/productoverview